

# Module I

# **BASIC THERMODYNAMICS**

REFERENCES:

***ENGINEERING THERMODYNAMICS*** by P.K.NAG 3<sup>RD</sup> EDITION

# ***LAWS OF THERMODYNAMICS***

- **0<sup>th</sup> law** – when a body A is in thermal equilibrium with a body B, and also separately with a body C, then B and C will be in thermal equilibrium with each other.
- **Significance**- measurement of property called temperature.



**RSET**  
RAJAGIRI SCHOOL OF  
ENGINEERING & TECHNOLOGY

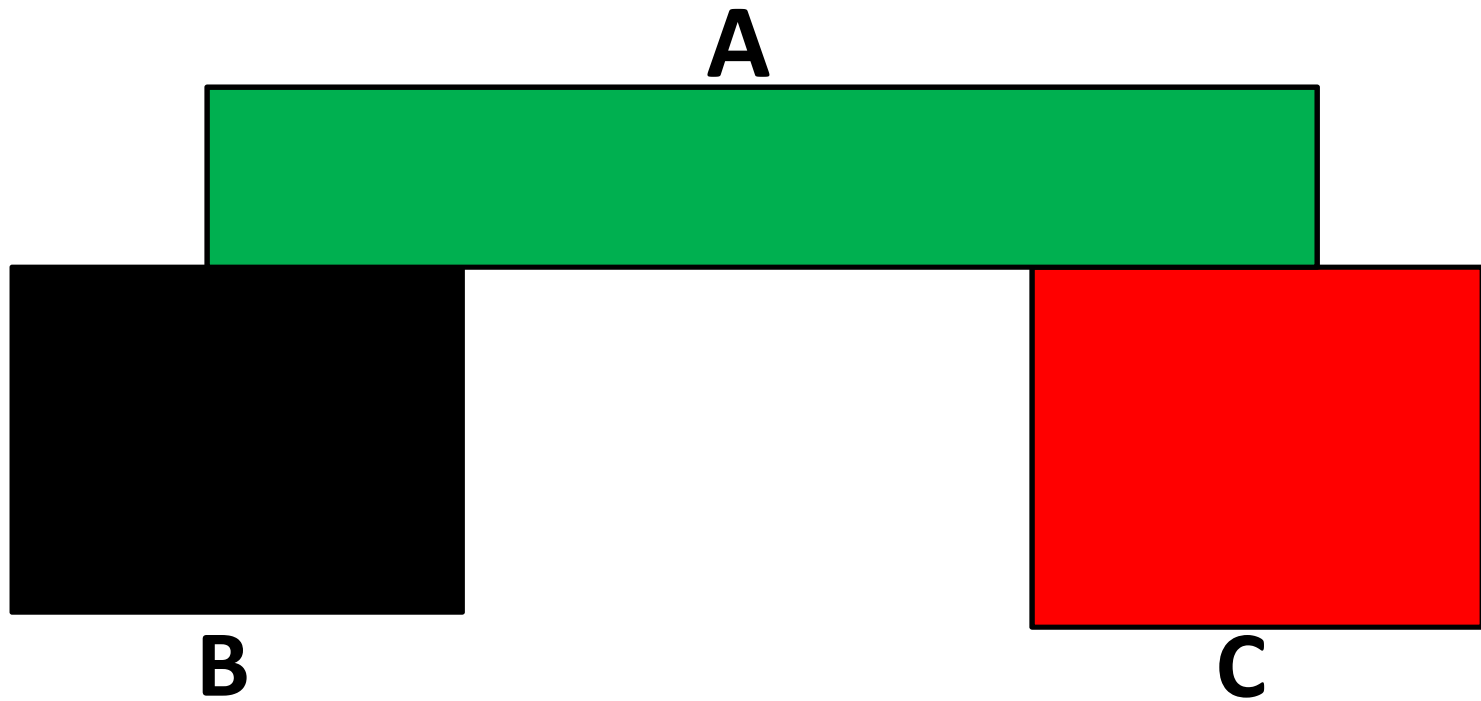

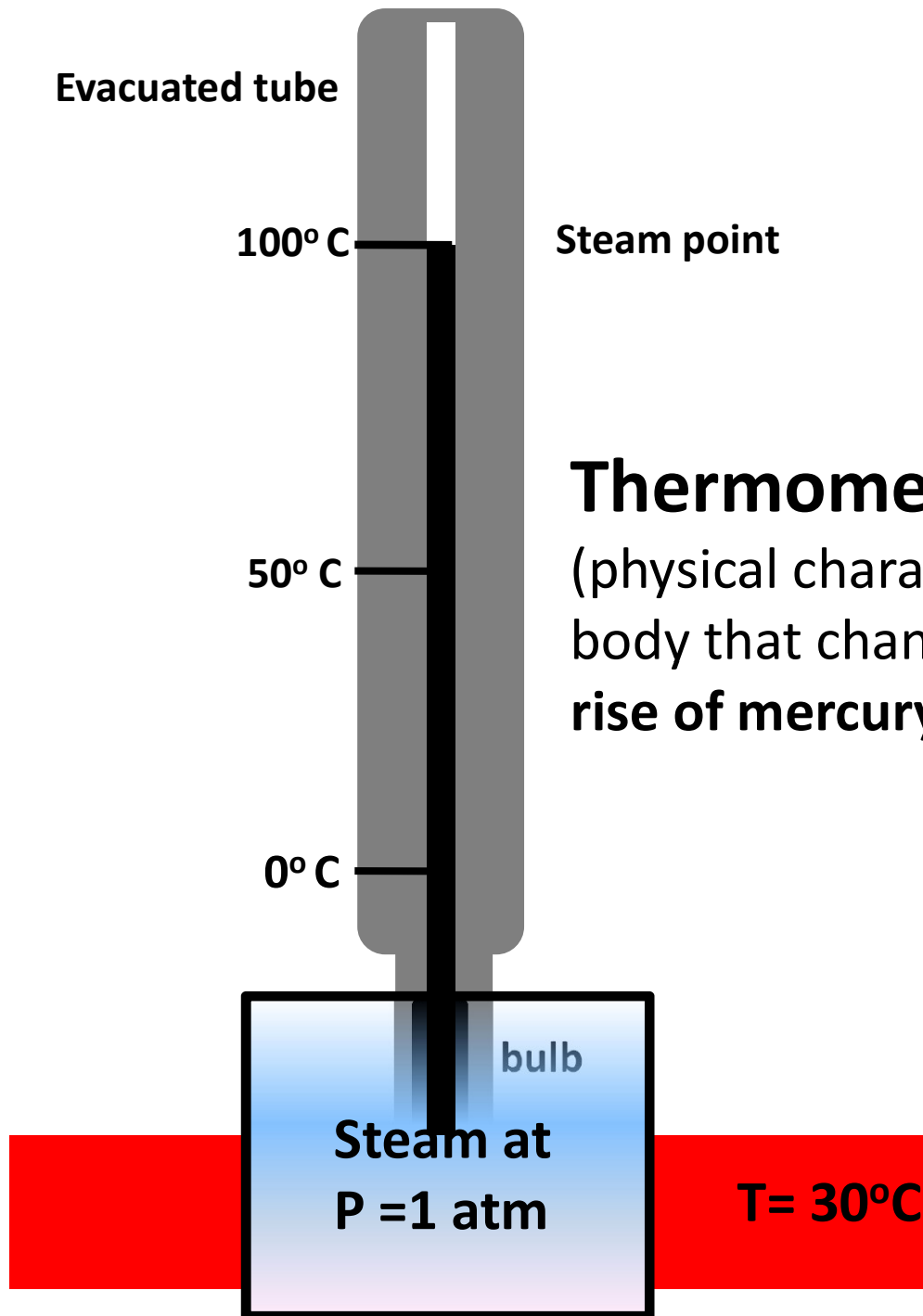

## Thermometric property

(physical characteristics of reference body that changes with temperature) –  
**rise of mercury in the evacuated tube**



**RSET**  
RAJAGIRI SCHOOL OF  
ENGINEERING & TECHNOLOGY

# REASONS FOR NOT TAKING ICE POINT AND STEAM POINT AS REFERENCE TEMPERATURES

- Ice melts fast so there is a difficulty in maintaining equilibrium between pure ice and air saturated water.

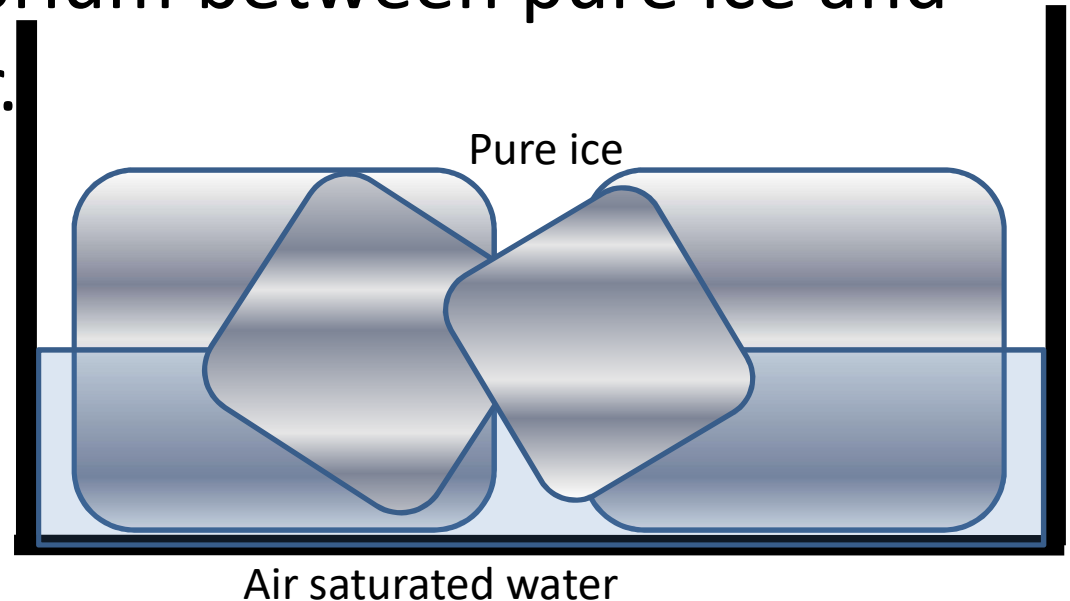

- Extreme sensitiveness of steam point with pressure



**RSET**

RAJAGIRI SCHOOL OF  
ENGINEERING & TECHNOLOGY

# TRIPLE POINT OF WATER AS NEW REFERENCE TEMPERATURE

- State at which ice liquid water and water vapor co-exist in equilibrium and is an easily reproducible state. This point is arbitrarily assigned a value 273.16 K
- i.e.  $T \text{ in K} = 273.16 \frac{X}{X_{\text{triple point}}}$
- X- is any thermometric property like P,V,R, rise of mercury, thermo emf etc.



**RSET**  
RAJAGIRI SCHOOL OF  
ENGINEERING & TECHNOLOGY

# OTHER TYPES OF THERMOMETERS AND THERMOMETRIC PROPERTIES

- Constant volume gas thermometers-  
pressure of the gas
- Constant pressure gas thermometers-  
volume of the gas
- Electrical resistance thermometer-  
resistance of the wire
- Thermocouple-  
thermo emf



# CELCIUS AND KELVIN(ABSOLUTE) SCALE

RSET  
RAJAGIRI  
ENGINEERING & TECHNOLOGY  
Thermometer

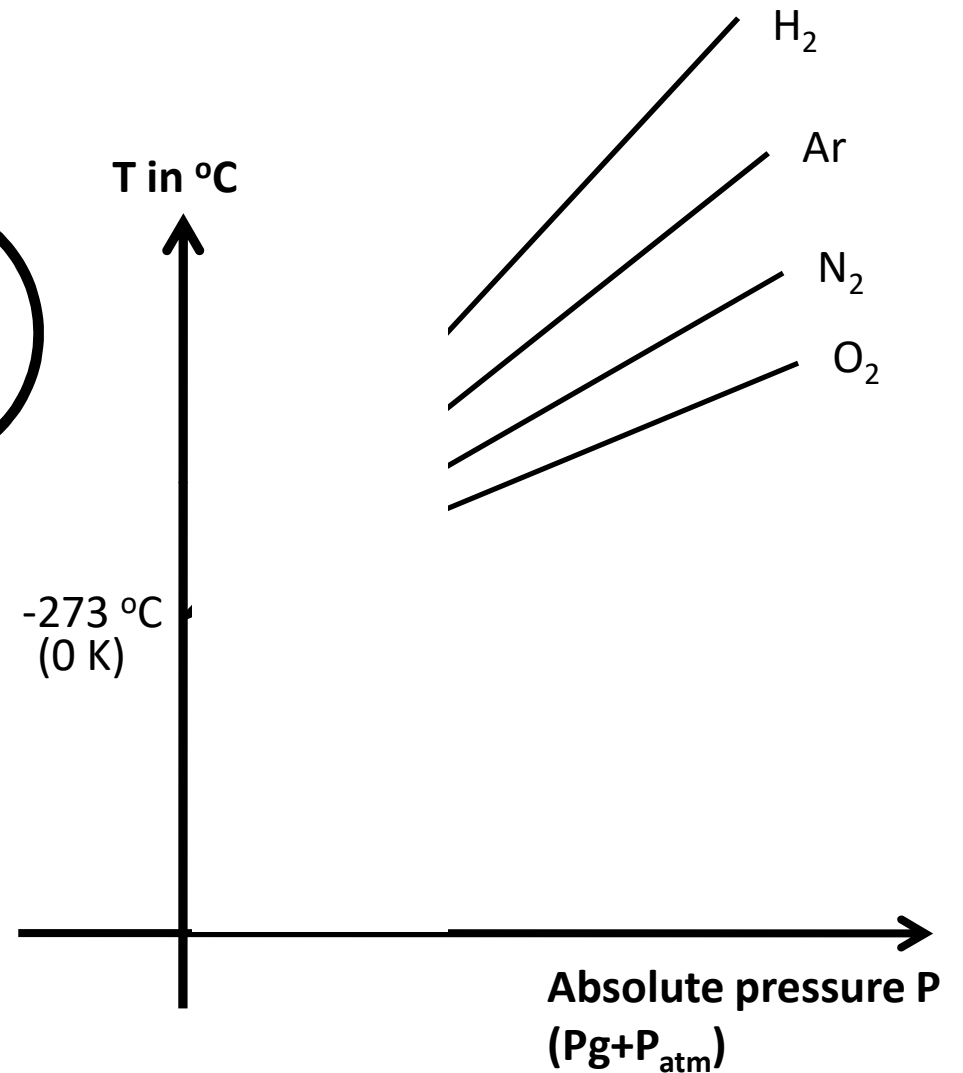
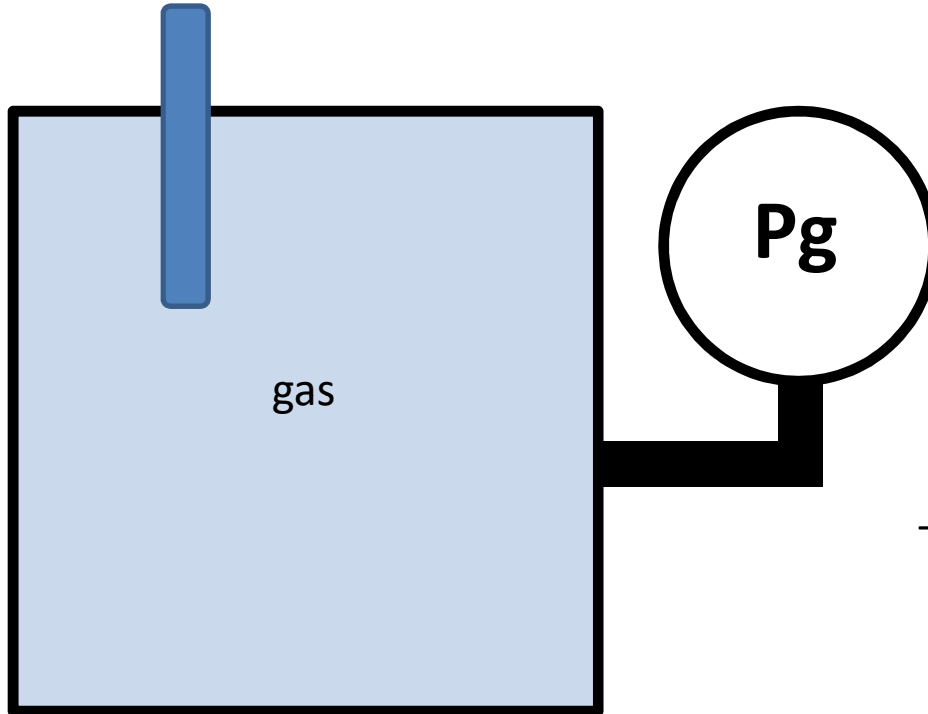

This absolute 0K cannot be obtained since it violates third law.





**RSET**

RAJAGIRI SCHOOL OF  
ENGINEERING & TECHNOLOGY

# ***SYSTEMS, BOUNDARY AND SURROUNDING***

Systems are any matter/ space on which our attention is focussed

Systems are of three types

- closed system – no matter interaction with the system, but there is energy interaction.
- Open system – there is matter as well as energy interaction with the system.
- Isolated system- there is neither matter nor energy interaction with the system. System and surroundings together constitutes an isolated system.



**RSET**

RAJAGIRI SCHOOL OF  
ENGINEERING & TECHNOLOGY

# ***CONTROL MASS / CLOSED SYSTEM E.G.***

moving boundary work output

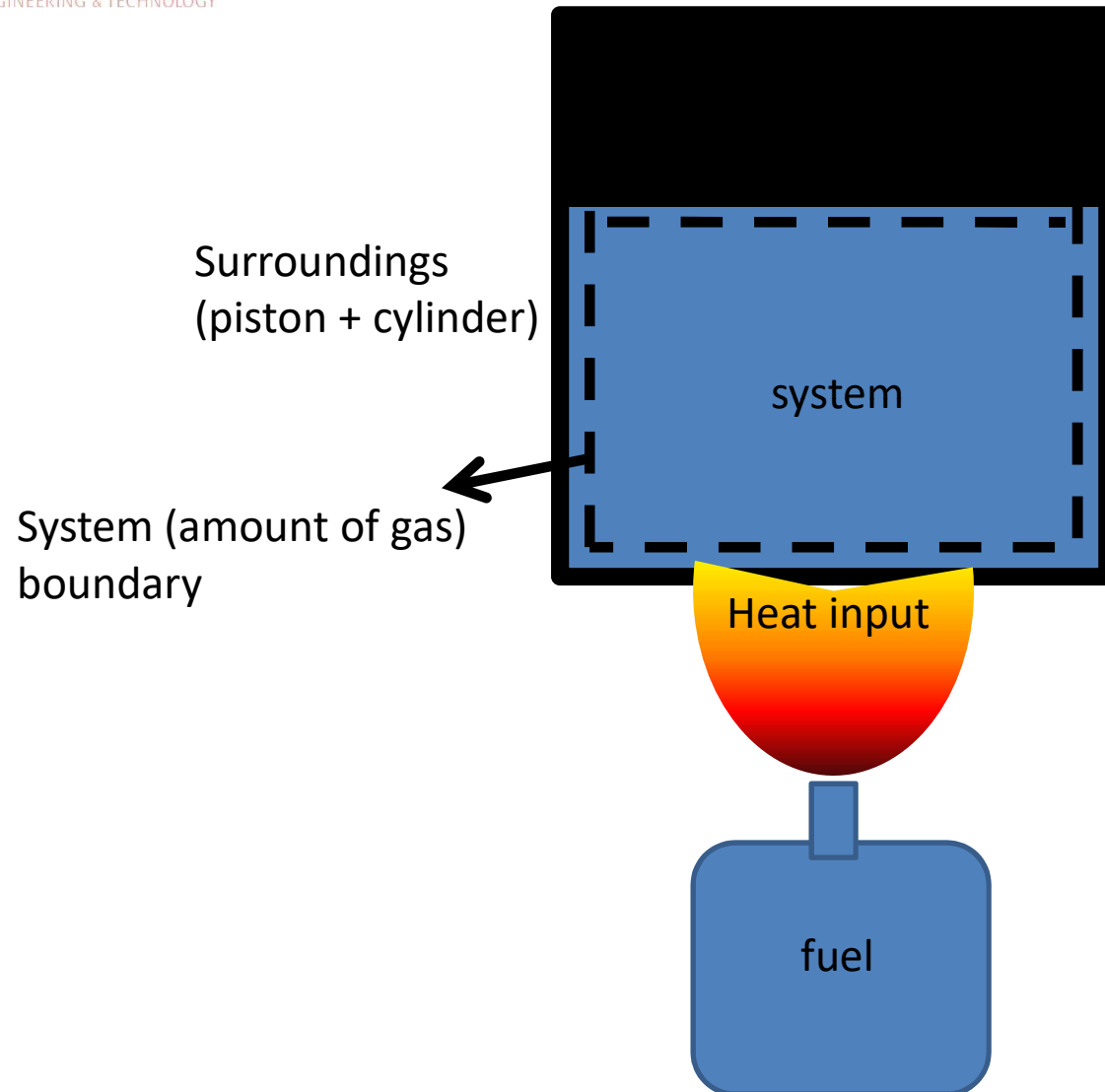

# ***OPEN SYSTEM E.G.***

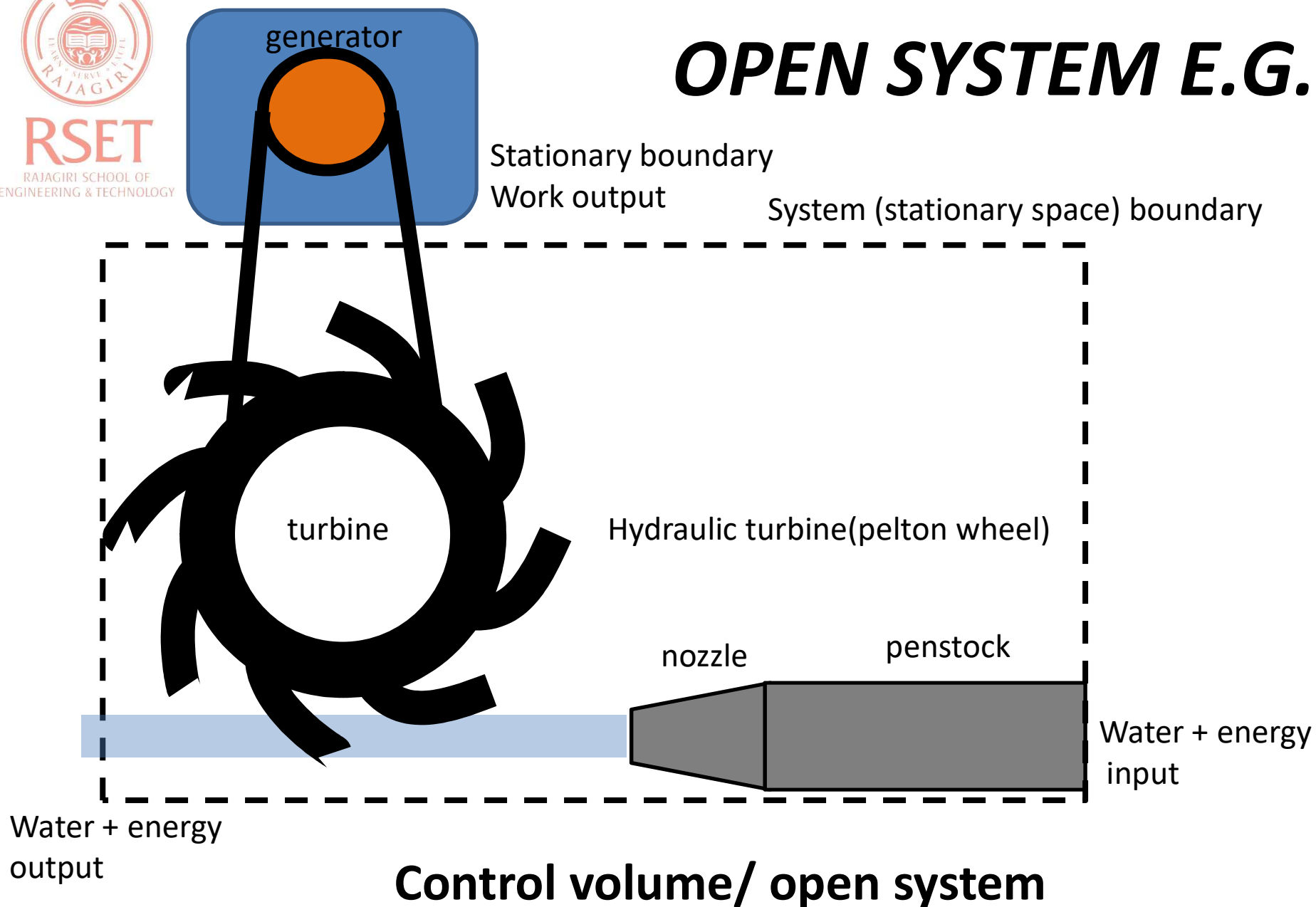

# ***PROPERTIES OF A SYSTEM***

- Characteristics of a system by which its physical condition may be described are called **properties of a system**. These are macroscopic in nature(physically measurable).

E.g. pressure, volume, temperature etc

- When all the **properties of a system have a definite value**, the system is said to exist at a **definite state**.



# STATE OF A SYSTEM

Low pressure  
Mean pressure  
High pressure

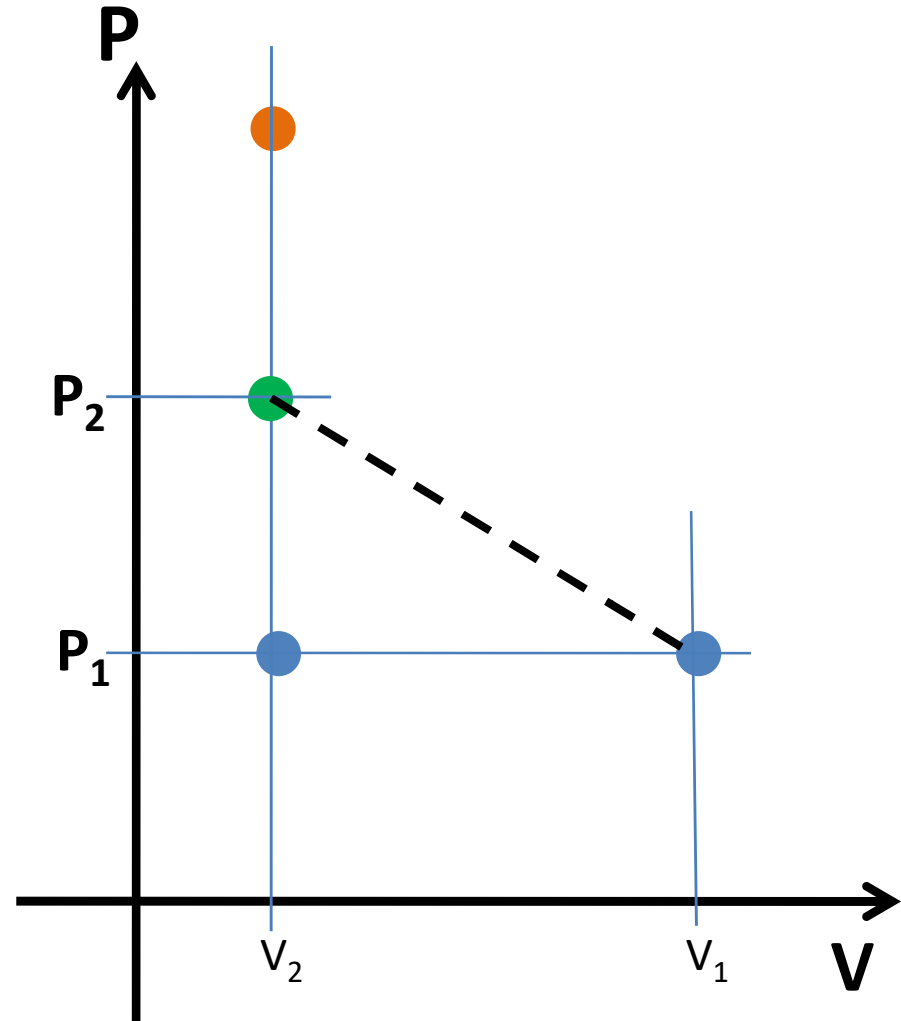

Any operation in which one or more of the properties of a system changes is called a change of state

# INTENSIVE AND EXTENSIVE PROPERTIES

- Intensive- independent of mass in the system
- Extensive- dependent of mass in the system

Mass= $m/2$	
Pressure = $P$	
Temp = $T$	
Volume= $V/2$	
Density,	
Mass/Volume = $\rho$	
Specific volume,	
Volume /mass = $u$	

*Capital letter denotes Extensive property (except P and T)  
and small letter denotes specific property(Extensive property per unit mass)*

# THERMODYNAMIC CYCLE

- Cycle consists of a series of change of state such that final state is same as the initial state

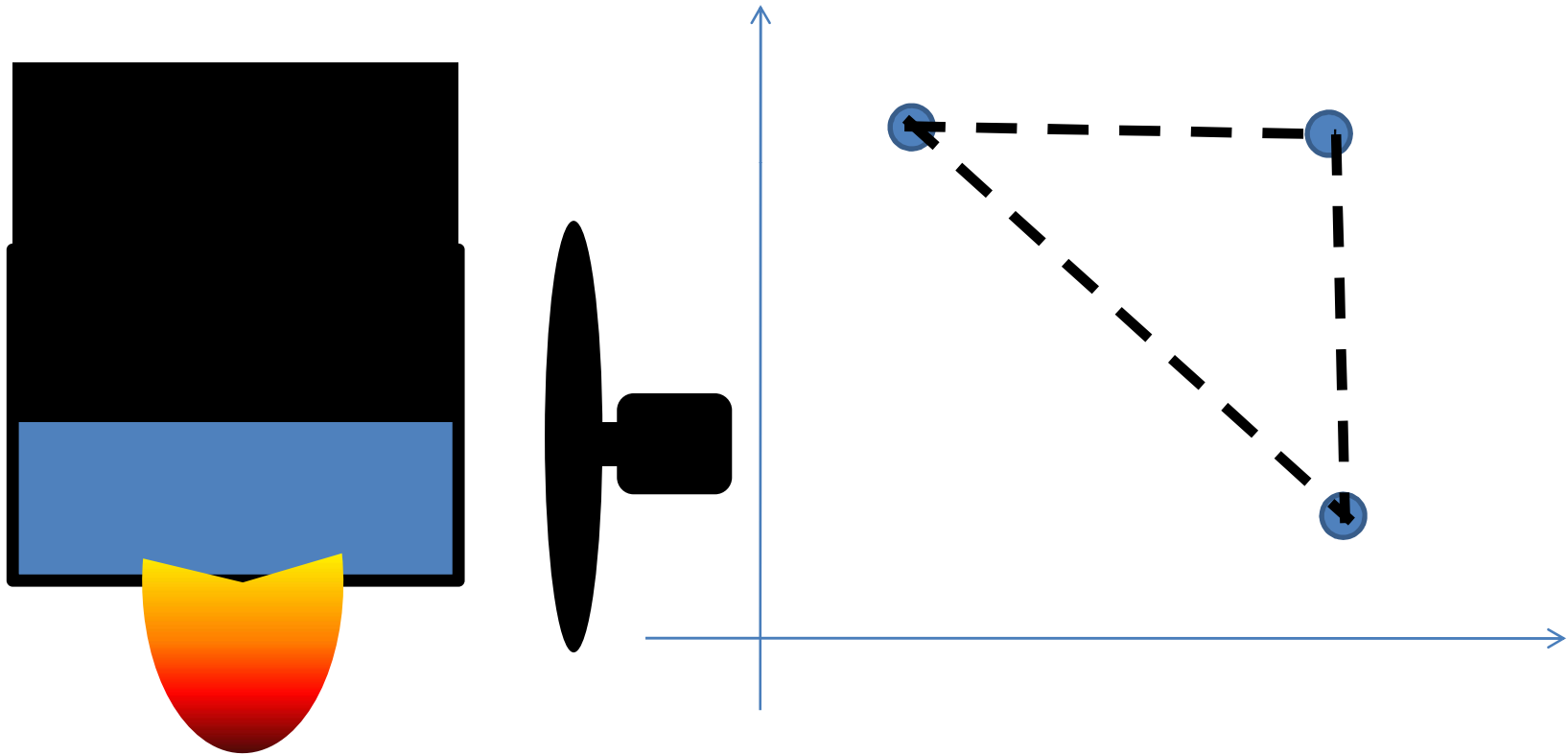



**RSET**

RAJAGIRI SCHOOL OF  
ENGINEERING & TECHNOLOGY

# Homogeneous and Heterogeneous systems

- A system consisting of only single phase is called homogeneous system

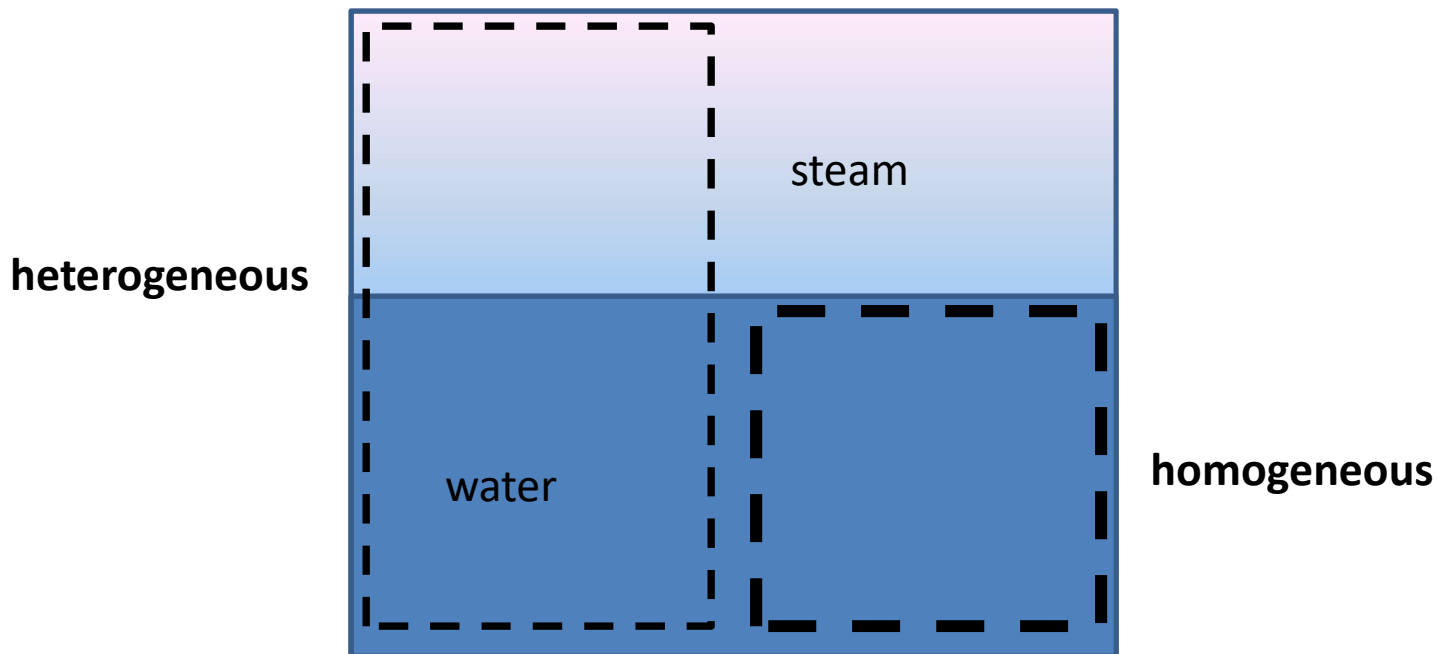

- A system consisting of more than one phase is heterogeneous system





**RSET**  
RAJAGIRI SCHOOL OF  
ENGINEERING & TECHNOLOGY

# ***WORK HEAT AND ENERGY***

# ENERGY

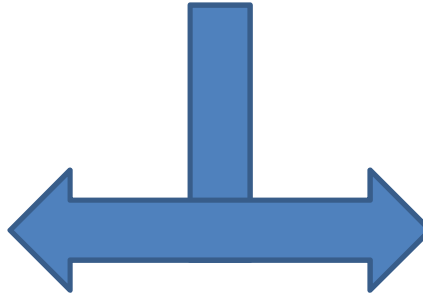

## ENERGY IN TRANSIT/MOTION

1. Energy that crosses the boundary of the system
2. Energy in the form of heat or work.
3. Specified as amount of energy transfer  
e.g. amount of heat transferred, amount of work transferred.
4. They are **not properties of a system**.
5. They are **path function** i.e. amount of energy transfer depends on the path followed by the system during a process

## ENERGY IN STORAGE

1. Energy that is stored in the system
2. Energy in form of KE, PE, internal energy (sum of all forms of molecular energy)
3. Specify as change in energy e.g. Change in KE, PE, etc
4. These are **properties of a system** like T,P,V, mass etc
5. They are **point functions** i.e. they are independent of the path followed by the system during a process.



**RSET**  
RAJAGIRI SCHOOL OF  
ENGINEERING & TECHNOLOGY

# DEFINING A PATH

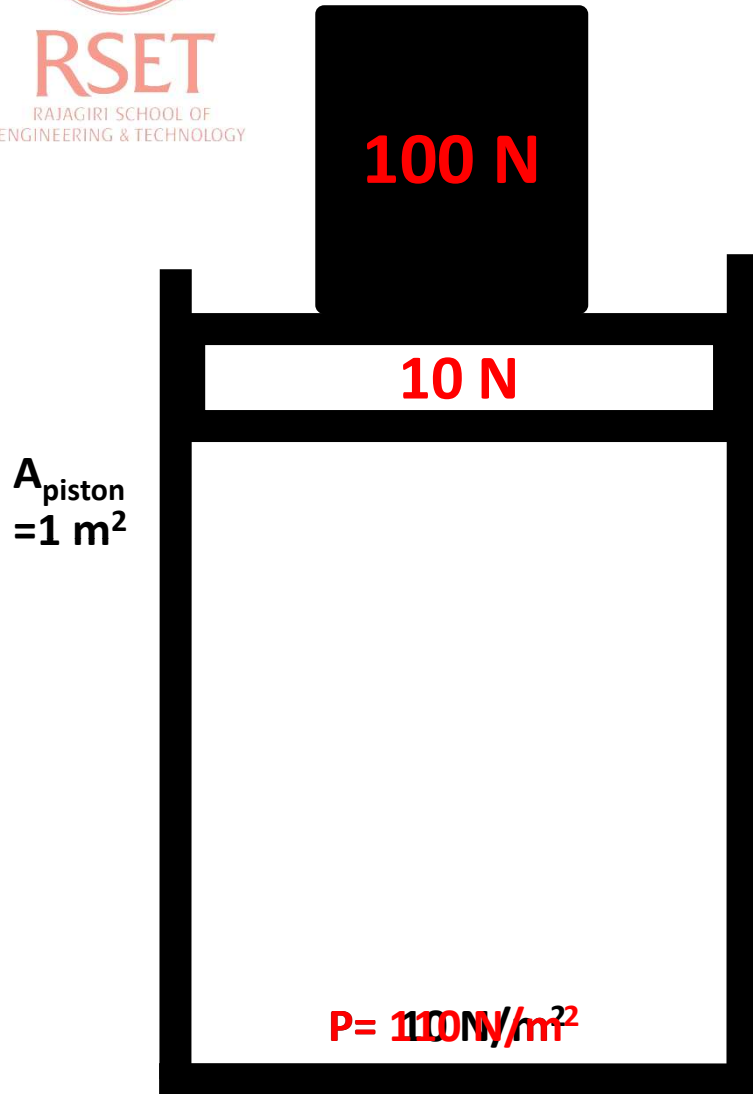

Now the system and surroundings are in equilibrium

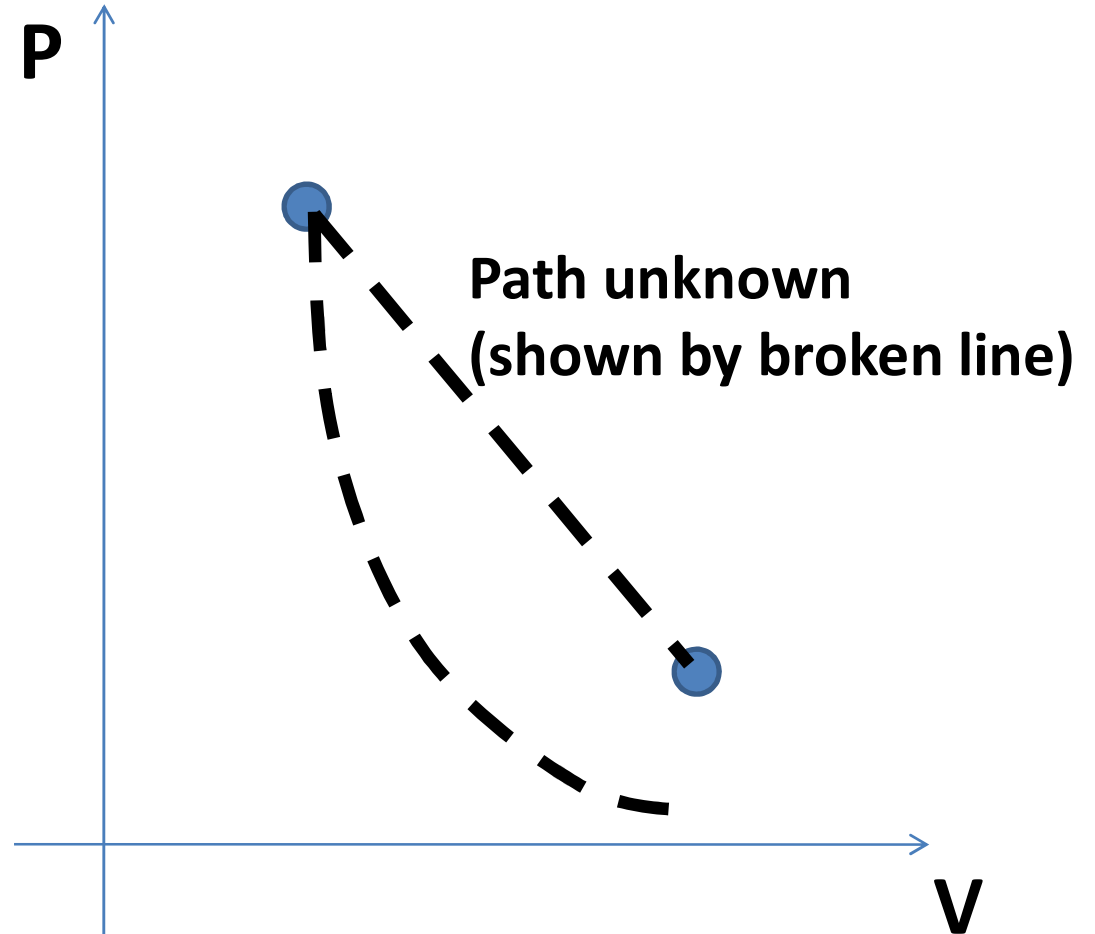

Now the system and surroundings are not in equilibrium



**RSET**  
RAJAGIRI SCHOOL OF  
ENGINEERING & TECHNOLOGY

# ***SPONTANEOUS PROCESS***

- fast process
- Path cannot be defined
- There is dissipation effects like friction
- System or surroundings can be restored to their initial state.
- System may not follow the same path if we reverse the process
- Spontaneous process are also called irreversible process.



**RSET**  
RAJAGIRI SCHOOL OF  
ENGINEERING & TECHNOLOGY

# DEFINING A PATH

**DECADES ARE**  
At last on a December 31<sup>st</sup> 2090  
**PASSING BY**

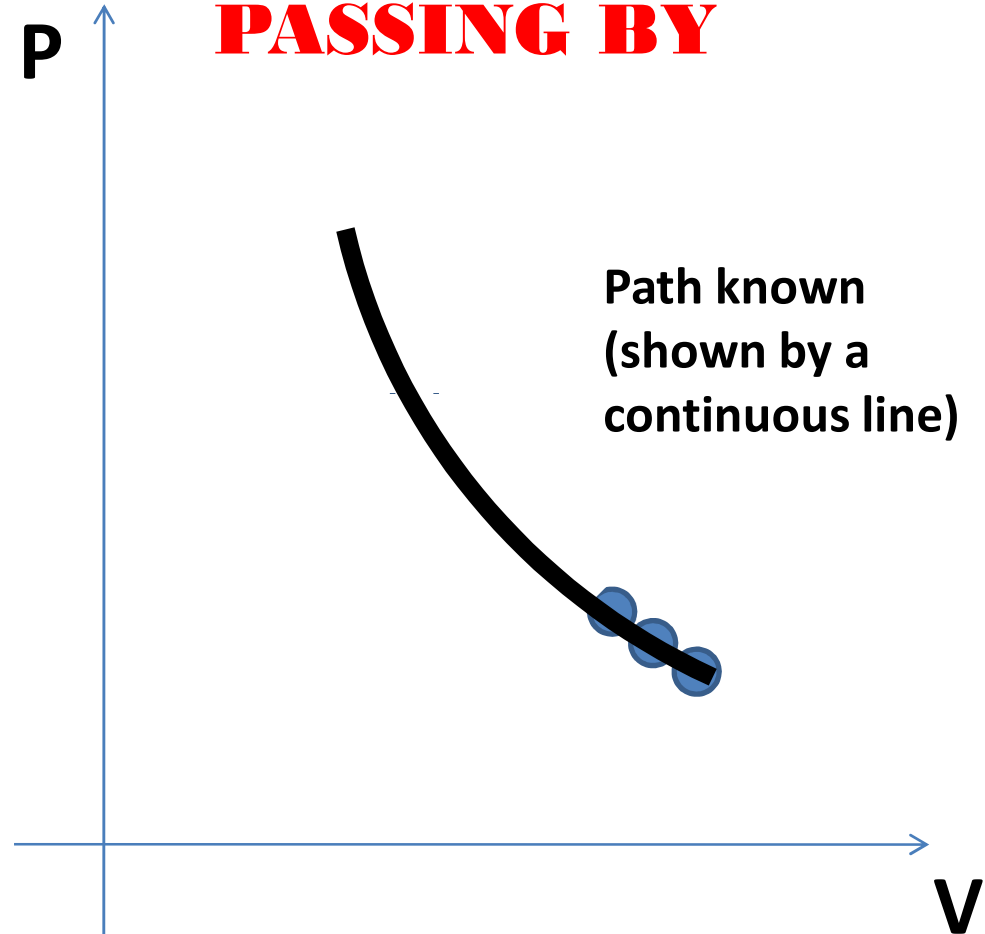
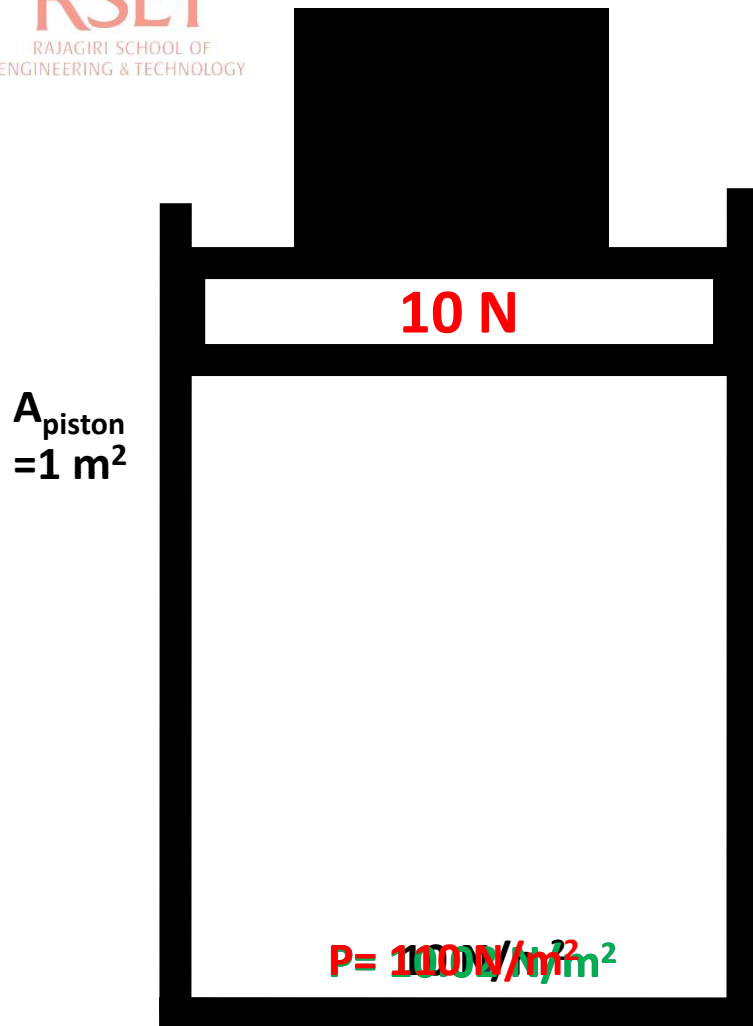

Now the system and surroundings are in  
equilibrium

Departure of states of the system from system  
thermodynamic equilibrium will be equilibrium  
infinitesimally small.



**RSET**  
RAJAGIRI SCHOOL OF  
ENGINEERING & TECHNOLOGY

# ***QUASI STATIC PROCESS***

- Infinitely slow process
- Path can be defined
- There is no dissipation effects like friction
- Both System and surroundings can be restored to their initial state.
- System follows the same path if we reverse the process
- Quasi static process are also called reversible process



# POINT FUNCTION/STATE FUNCTION

Cyclic integral (integral over a cycle)  
of any point function (property) is = 0

RAJAGIRI INSTITUTE OF  
ENGINEERING & TECHNOLOGY

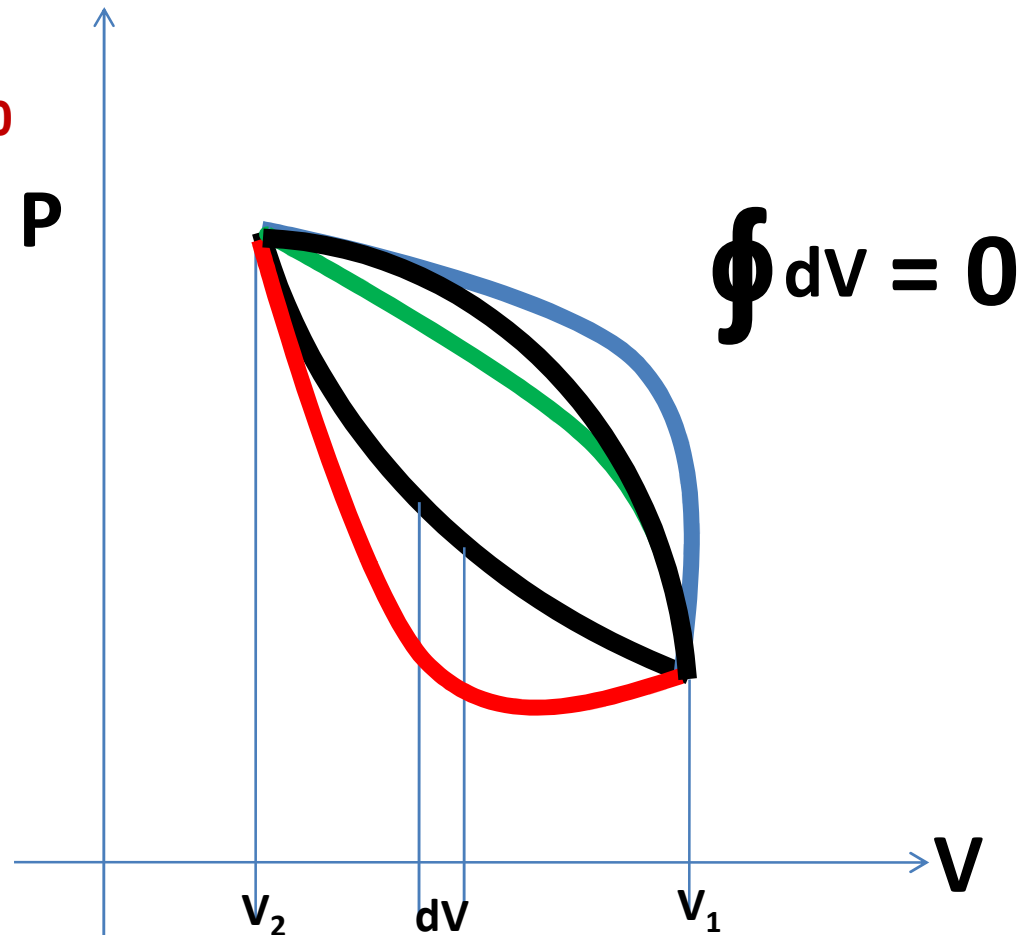
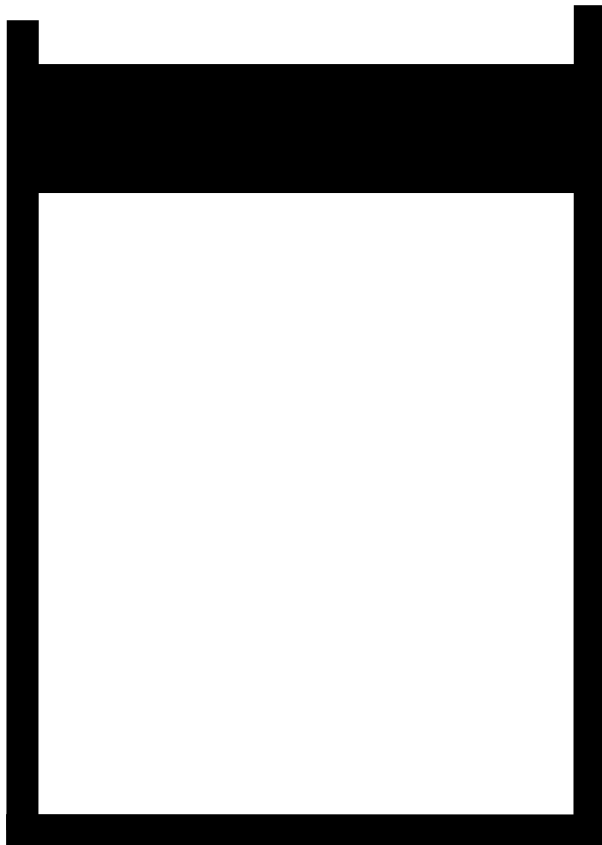

$$\int dV = V_2 - V_1 = \Delta V$$

$$\int dP = P_2 - P_1 = \Delta P$$

$$\int dT = T_2 - T_1 = \Delta T$$

These are  
called exact  
differential  
functions.



# PATH FUNCTION

So heat and work are path functions.  
Also they are not exact differentials

RAJAGIRI SCHOOL OF  
ENGINEERING & TECHNOLOGY

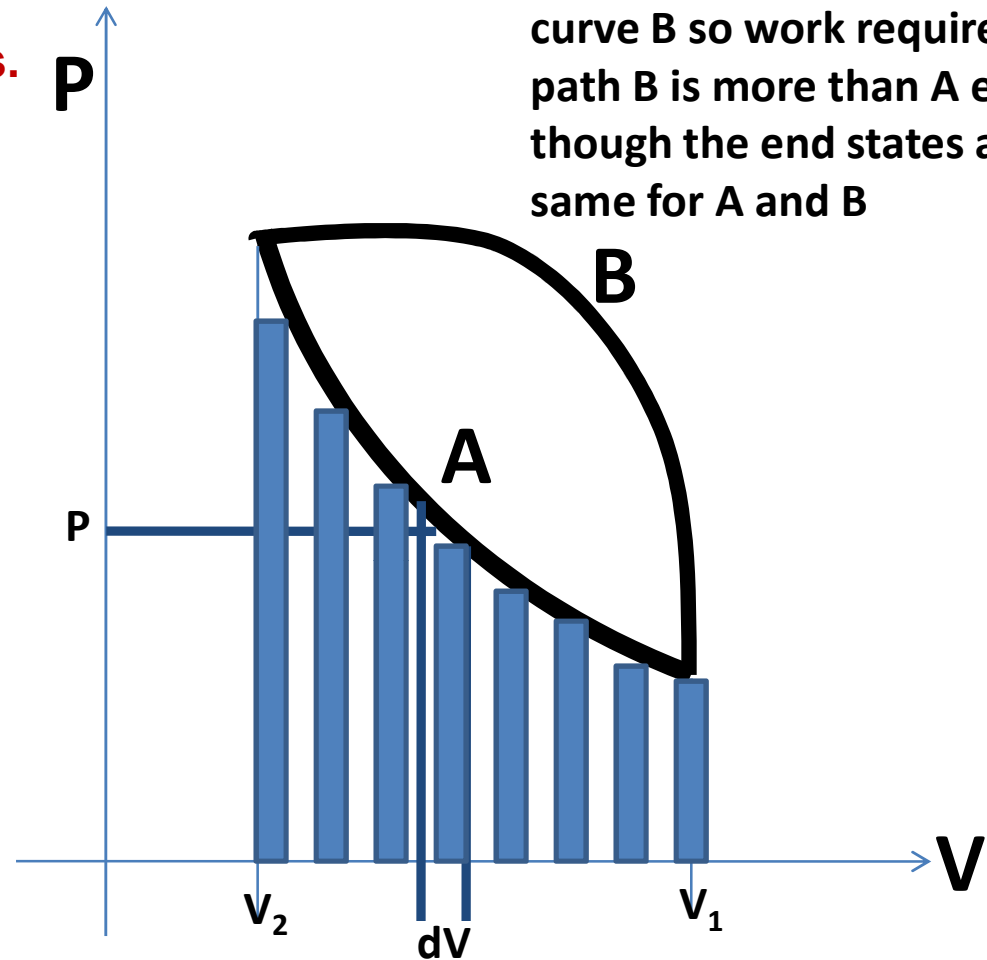
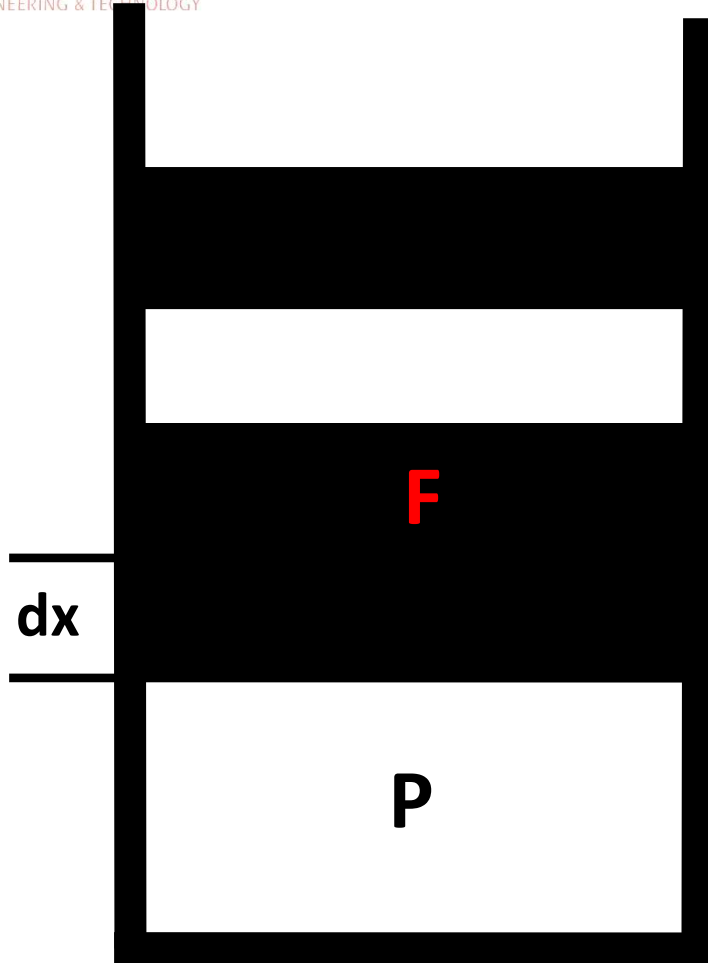

Path B has more area than curve A so work required in path B is more than A even though the end states are same for A and B

Then the total work required to move the piston from  $V_1$  to  $V_2$ ,  $W = \int P dV =$  area under PV curve

Small amount of work required to move the piston through a distance  $dx = \delta W = F dx = P A dx = PdV$





**RSET**

RAJAGIRI SCHOOL OF  
ENGINEERING & TECHNOLOGY

# *Additional comments on heat and work transfer*

- Heat transfer to a system is taken as positive
- Heat transfer from a system is taken as negative
- Work transfer to a system is taken as negative
- Work transfer from a system is taken as positive

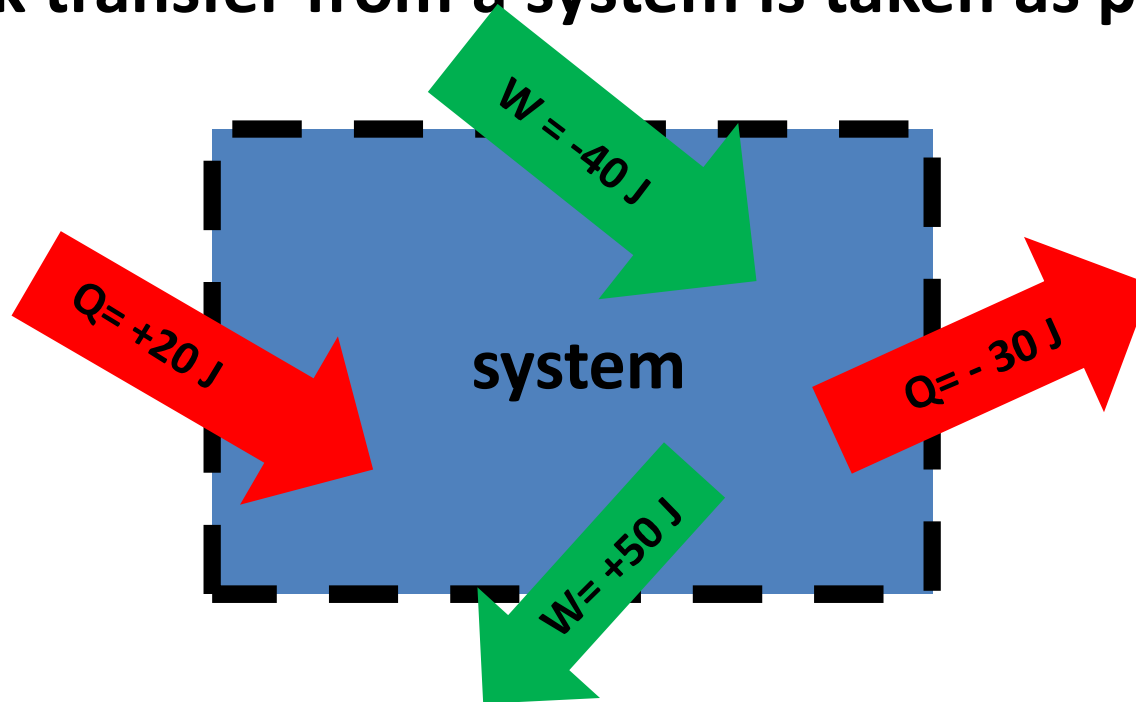



**RSET**  
RAJAGIRI SCHOOL OF  
ENGINEERING & TECHNOLOGY

# ***FIRST LAW***



**RSET**

RAJAGIRI SCHOOL OF  
ENGINEERING & TECHNOLOGY

- Law of conservation of energy-  
Energy can neither be created  
nor destroyed. It can only be  
converted from one form to  
another, here  $Q = W + \Delta U$

$$Q - W = \Delta U$$

$$\delta Q - \delta W = dU$$

**In differential form**

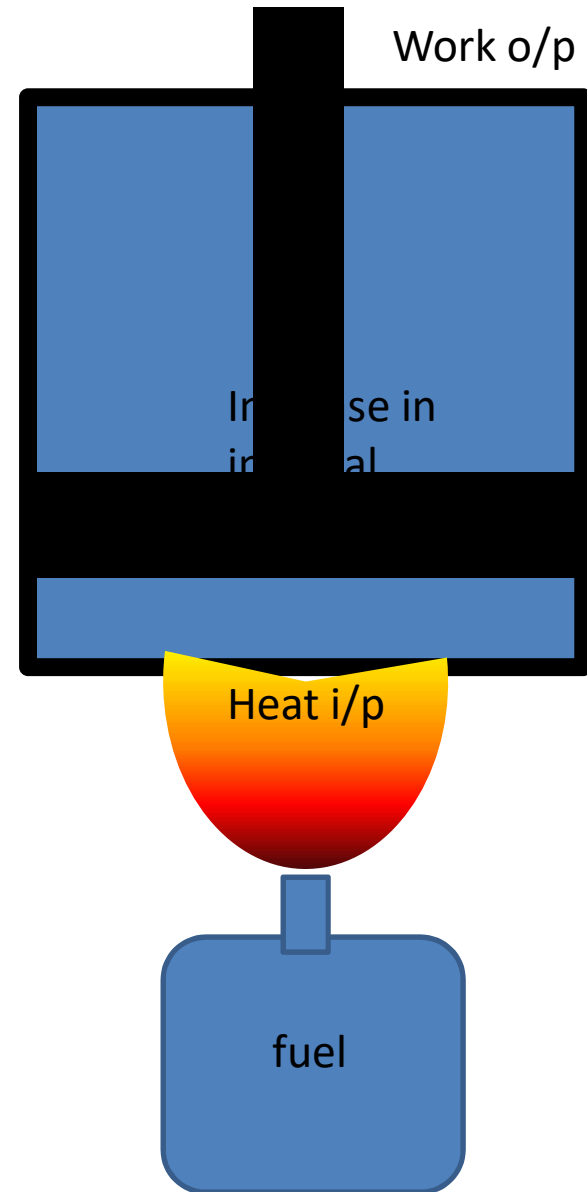

## ***Specific heat (c)***

- Defined as amount of heat required to raise the temperature of a unit mass of any substance through a unit degree. Its SI unit is J/kg K or J/kg°C
- i.e.  $c = Q/m \Delta T$  or  $c = \delta Q /m dT$
- $\delta Q = m c dT$
- $Q = m c \Delta T$



RSET

RAJAGIRI SCHOOL OF  
ENGINEERING & TECHNOLOGY

## ***Specific heat at constant volume( $c_v$ )***

- Defined as amount of heat required to raise the temperature of a unit mass of any substance through a unit degree in a constant volume process. Its SI unit is J/kg K or J/kg°C
- *i.e.*  $c_v = Q/m \Delta T$  or  $c_v = \delta Q /m dT$
- $\delta Q = m c_v dT$
- $Q = m c_v \Delta T$



**RSET**

RAJAGIRI SCHOOL OF  
ENGINEERING TECHNOLOGY

**final**

**internal  
energy**

$U_2$

**Initial  
internal  
energy**

$U_1$

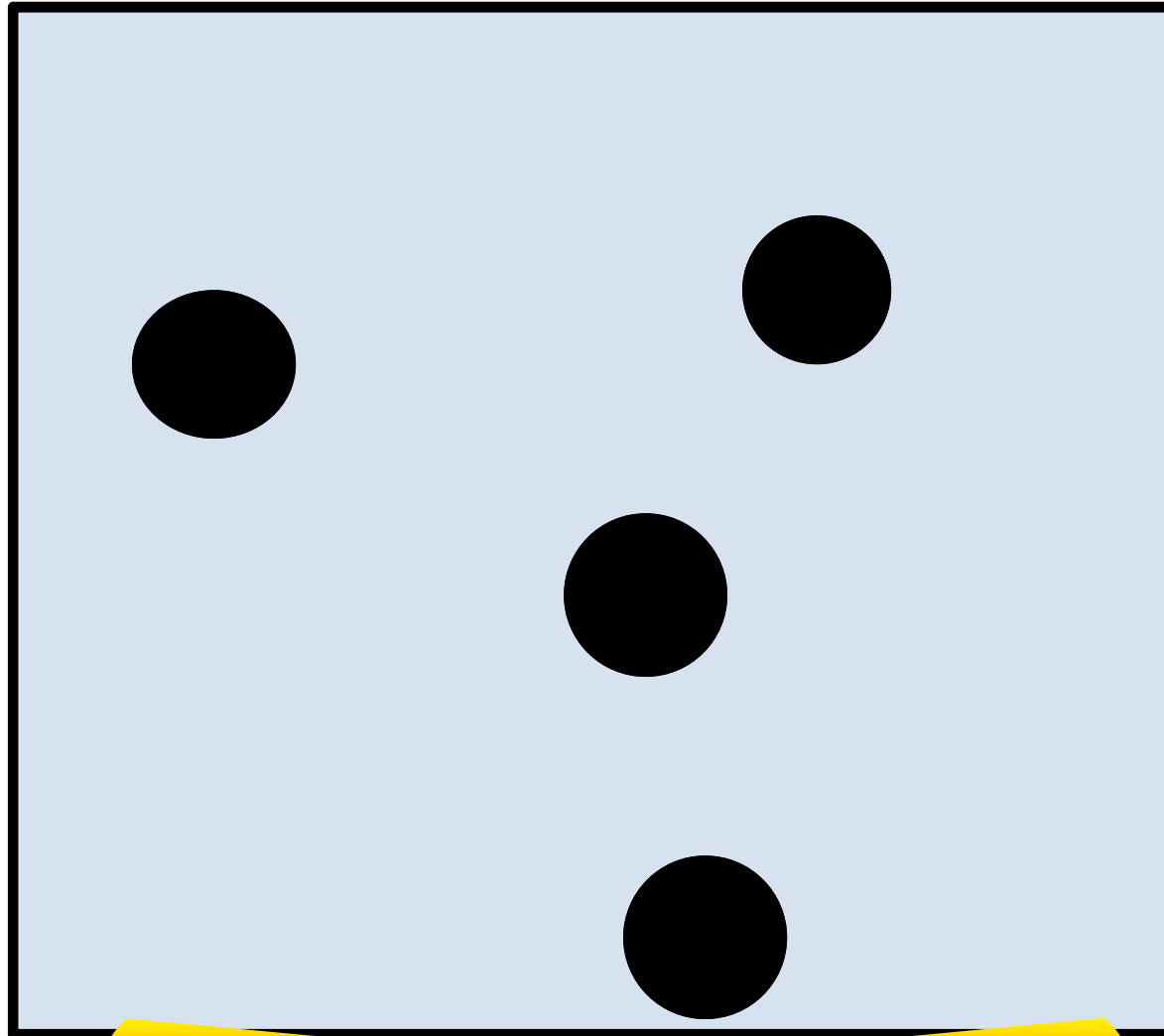

**heat**

$$\delta Q - \delta W = dU$$

$$\delta Q = dU$$

$$m c_v dT = dU$$

$$c_v = (du/dT)_v$$



**RSET**

RAJAGIRI SCHOOL OF  
ENGINEERING & TECHNOLOGY

## ***Specific heat at constant pressure( $c_p$ )***

- Defined as amount of heat required to raise the temperature of a unit mass of any substance through a unit degree in a constant pressure process. Its SI unit is J/kg K or J/kg°C
- *i.e.  $c_p = Q/m \Delta T$  or  $c_p = \delta Q /m dT$*
- *$\delta Q = m c_p dT$*
- *$Q = m c_p \Delta T$*



# Specific heat at constant pressure ( $c_p$ )

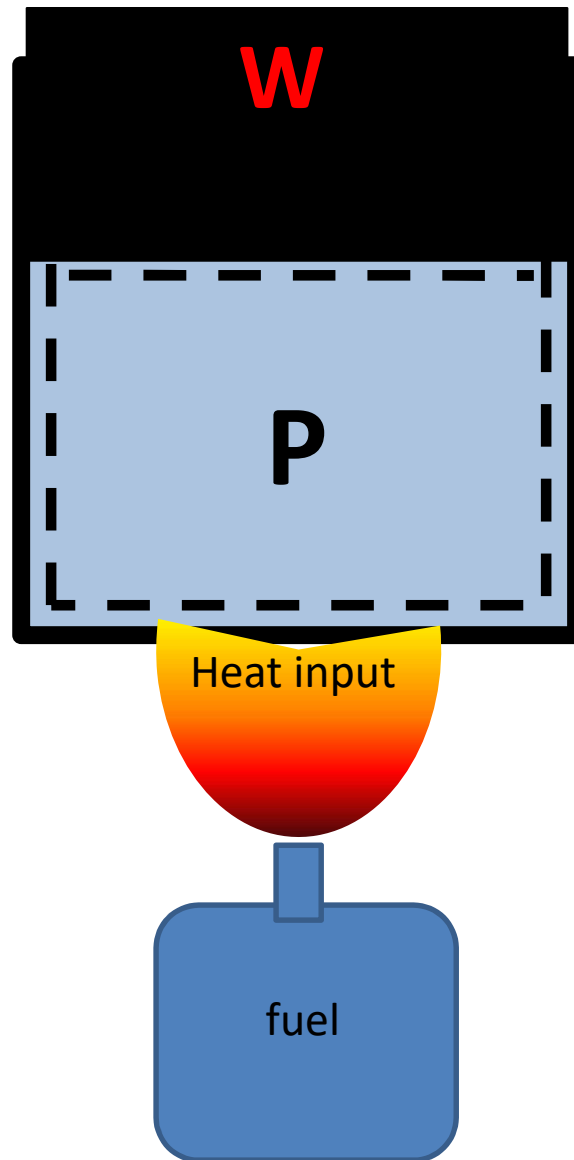

moving boundary work output

$$\delta W = PdV$$

$$\delta Q - \delta W = dU$$

$$\delta Q - PdV = dU$$

$$m c_p dT = dU + PdV$$

$$\text{Enthalpy } H = U + PV$$

$$h = u + Pv$$

$$dh = du + d(pv)$$

In a constant pressure process

$$vdP = 0$$

$$\text{So } dh = du + pdv$$

$$c_p = \left(\frac{dh}{dT}\right)_p$$



# AN EXPERIMENT BY JOULES ON FIRST LAW

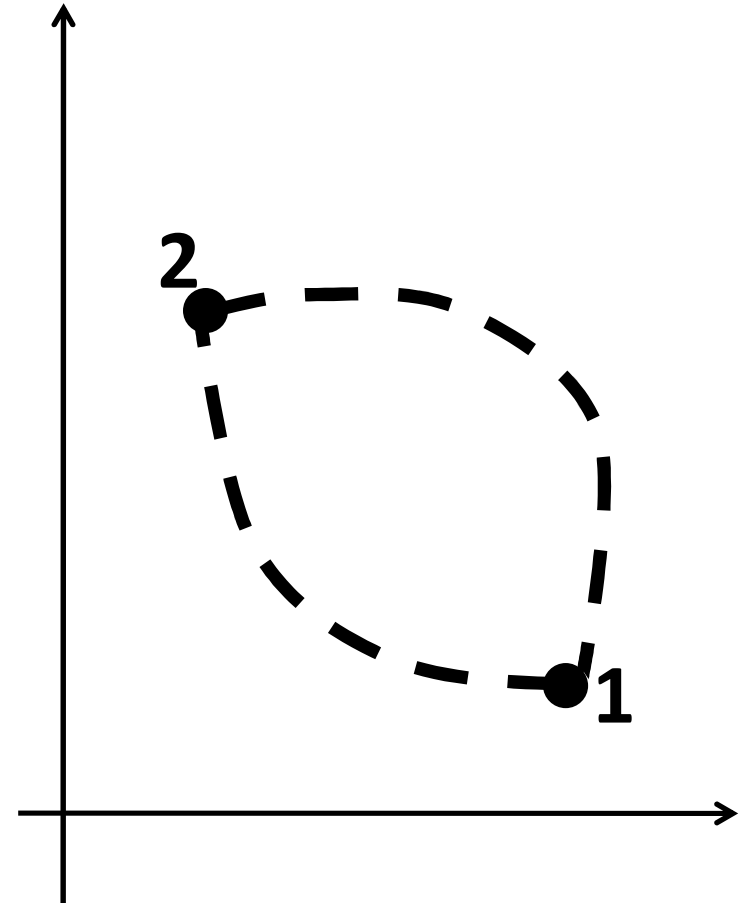
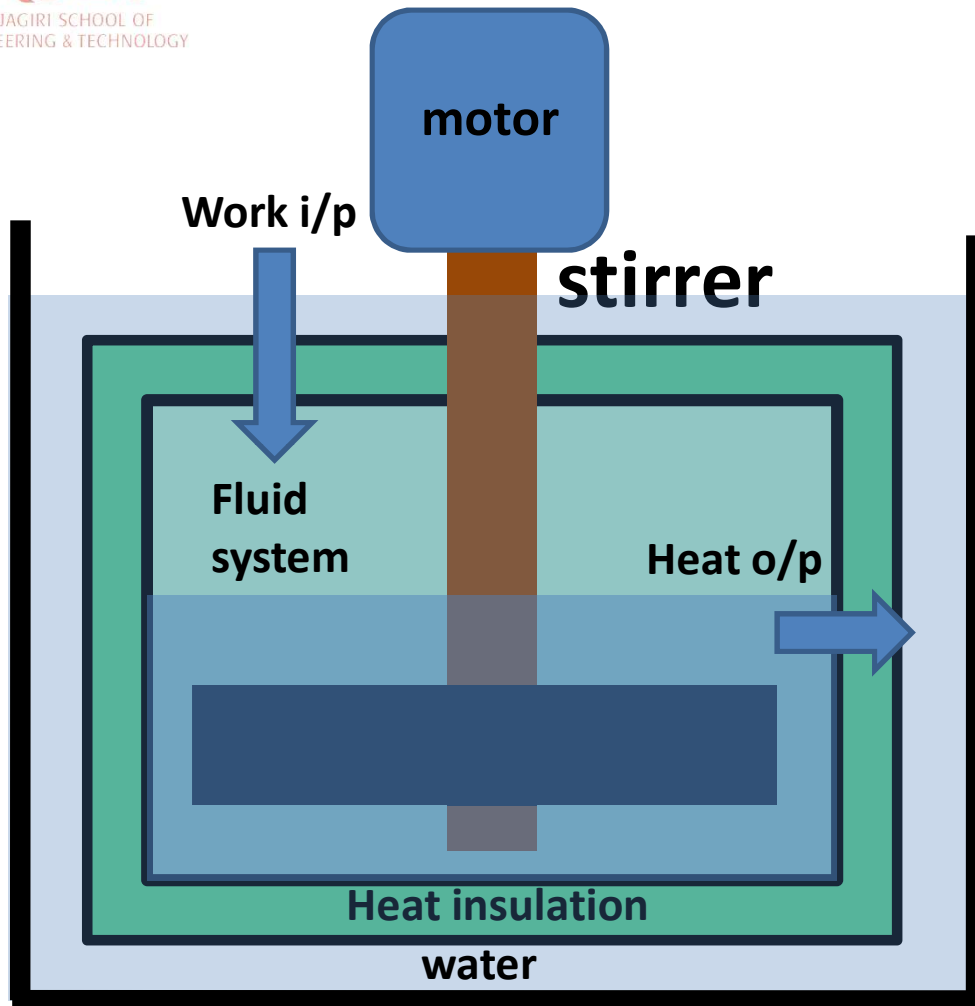

Joule found that heat output in process 2-1 was exactly equal to work input in process 1-2

# Joules experiment cont.

## Process 1-2

- Work transfer =  $W_{1-2}$
- heat transfer  $Q_{1-2} = 0$  J (heat insulation wall)

## Process 2-1

- Work transfer  $W_{2-1} = 0$  J (no work done)
- Heat transfer =  $Q_{2-1}$
  
- He found that  $W_{1-2} = Q_{2-1}$
- I.e. in the cycle 1-2-1,  $W_{1-2} + W_{2-1} = Q_{1-2} + Q_{2-1}$
- **in a cycle net work transfer = net heat transfer**
- **i.e. in a cycle  $\Sigma W = \Sigma Q$**
- **In differential form , in a cycle**

$$\oint \delta W = \oint \delta Q$$



# INTERNAL ENERGY A PROPERTY?

From the first law we found  
that,

In a cycle

$$\Sigma Q = \Sigma W$$

Consider cycle 1-A-2-B-1

$$Q_A + Q_B = W_A + W_B$$

$$Q_A - W_A = -Q_B + W_B$$

$$\Delta U_A = -\Delta U_B$$

Consider cycle 1-A-2-C-1

$$Q_A + Q_C = W_A + W_C$$

$$Q_A - W_A = -Q_C + W_C$$

$$\Delta U_A = -\Delta U_C$$

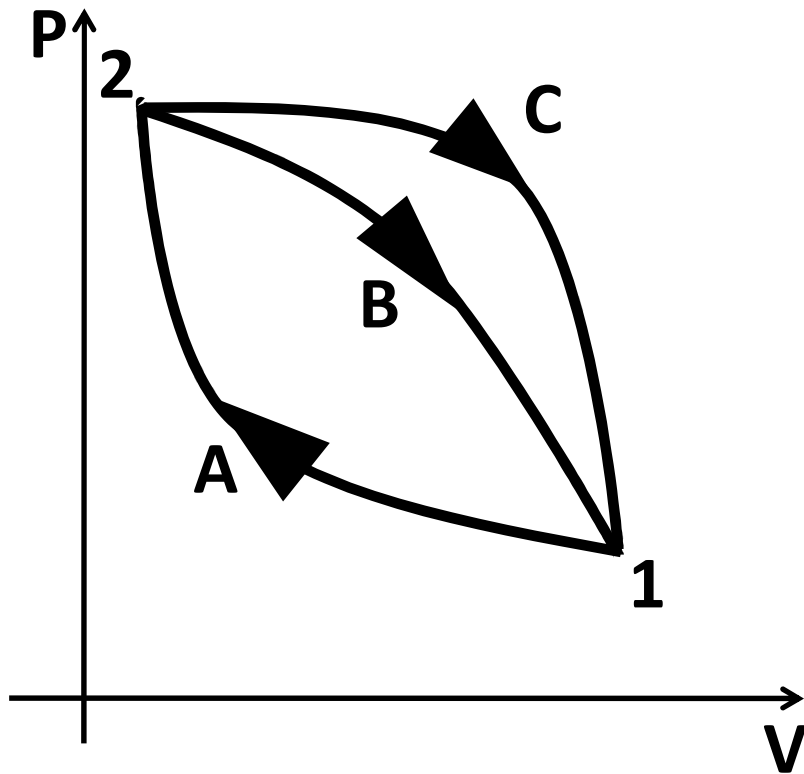

i.e.  $\Delta U_B = \Delta U_C$

i.e. *U is independent of path followed, so U is a property*

# Practice problem 1(p66)

- A stationary mass of gas is compressed without friction from an initial state of  $0.3 \text{ m}^3$  and  $0.105 \text{ MPa}$  to a final state of  $0.15 \text{ m}^3$  and  $0.105 \text{ MPa}$ . The pressure remaining constant during the process. There is a transfer of  $37.6 \text{ kJ}$  of heat from the gas during the process. How much does the internal energy of the gas change?

***-21.85 kJ***

# Practice problem 2(p66)

- When a system is taken from state a to state b, in the fig along the path acb, 84 kJ of heat flows into the system and system does 32 kJ of work.

1. How much will the heat that flows into the system along the path adb be, if the work done is 10.5 kJ?

**62.5 kJ**

2. When the system is returned from b to a along the curved path, the work done on the system is 21 kJ. Does the system absorb or liberate heat, and how much of the heat is absorbed or liberated?

**-73 kJ**

3. If  $U_a = 0$  kJ and  $U_d = 42$  kJ, find the heat absorbed in the process ad and db.

**52.5 kJ**  
**10 kJ**



**RSET**  
RAJAGIRI SCHOOL OF  
ENGINEERING & TECHNOLOGY

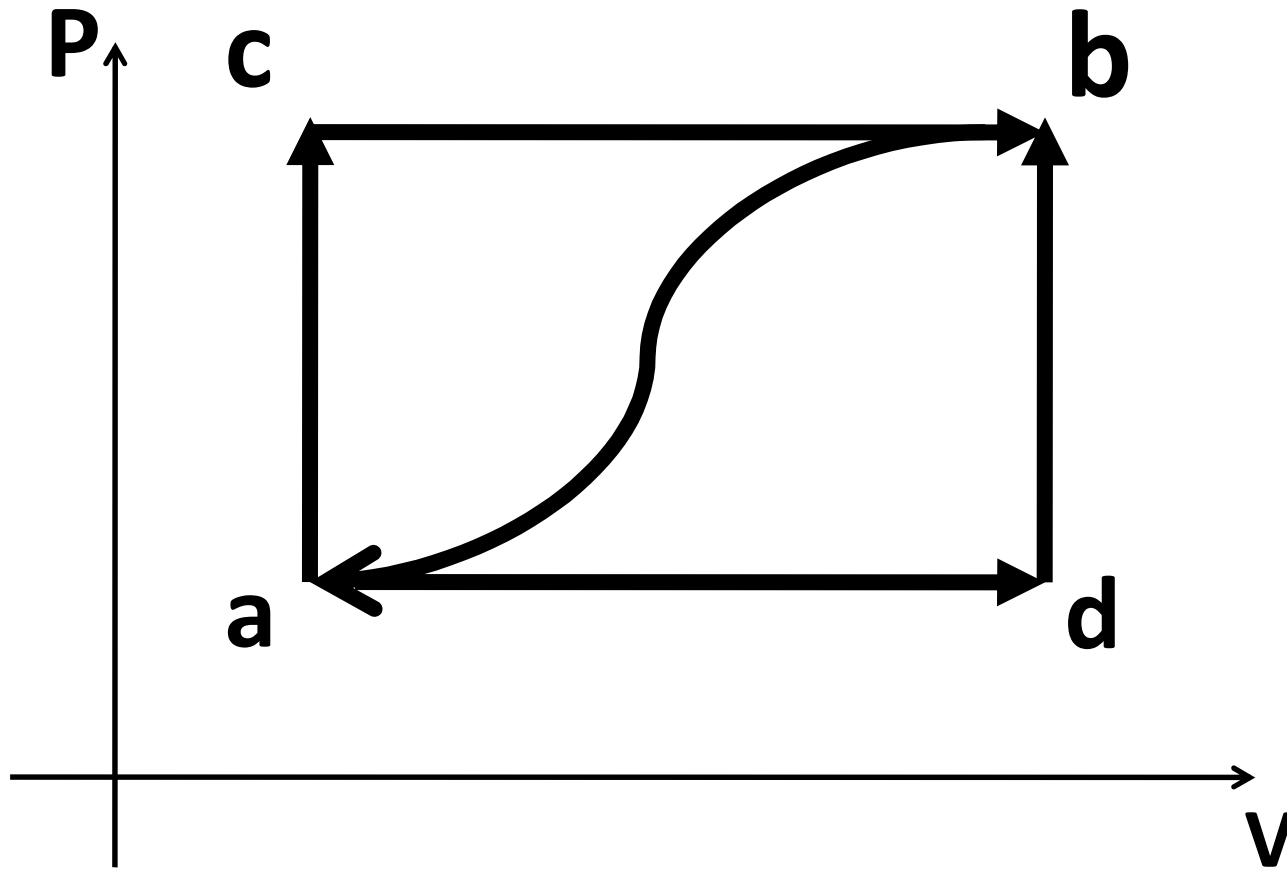

## Practice problem 3(p67)

- A piston and cylinder machine contains a fluid system which passes through a complete cycle of four processes. During a cycle, the sum of all heat transfer is  $-170$  KJ. The system completes 100 cycles per minute. Complete the following table showing the method for each item, and compute the net rate of work input in KW.



<u>Process</u>	<u>Q(KJ/min)</u>	<u>W(KJ/min)</u>	<u><math>\Delta E</math>(KJ/min)</u>
a-b	0	2170	<b>-2170</b>
b-c	21000	0	<b>21000</b>
c-d	-2100	<b>34500</b>	<b>-36600</b>
d-a	<b>-35900</b>	<b>-53670</b>	<b>17770</b>

$$W_{net} = -283.3 \text{ kW}$$





# Practice problem 4(p68)

**RSET**  
RAJAGIRI SCHOOL OF  
ENGINEERING & TECHNOLOGY

- Internal energy of a certain substance is given by the following

eqn, -----
$$u = 3.56 p v + 84$$

Where  $u$  is in kJ/kg,  $P$  in kPa,  $v$  in  $\text{m}^3/\text{kg}$ .

A system composed of 3 kg of this substance expands from initial pressure of 500 kPa and a volume of 0.22  $\text{m}^3$  to a final pressure of 100 kPa in a process in which pressure and volume is related by  $Pv^{1.2} = \text{Constant}$ .

- If the expansion is quasistatic find  $Q$ ,  $\Delta U$  and  $W$  for the process. **36.5 kJ 91 kJ 127.5 kJ**
- In another process the same system expands from same initial state to same final state as in previous part, but the heat transfer in this case is 30 kJ. Find the work transfer for this process. **121 kJ**
- Explain the difference in work transfer in both processes.

## Practice problem 5(p69)

- A fluid is confined in a cylinder by a spring loaded, frictionless piston so pressure in the fluid is a linear function of volume ( $P = a + bV$ ). The internal energy of the fluid is given by the equation

$$U = 34 + 3.15 PV$$

if the fluid changes from an initial state of 170 kPa, 0.03 m<sup>3</sup> to final state of 400kPa, 0.06m<sup>3</sup>, with no work other than done on the piston, find the direction and magnitude of work and heat transfer.

$$W = 8.55 \text{ kJ}$$

$$Q = 68.05 \text{ kJ}$$

## Practice problem 6(p70)

- A stationary cycle goes through a cycle shown in the figure comprising the following processes.
- Process 1-2 isochoric (constant Volume) heat addition of 235KJ/kg.
- Process 2-3 adiabatic (no heat transfer) expansion to its original pressure with loss of 70 KJ/kg in internal energy.
- Process 3-1 isobaric (constant Pressure) compression to its original volume with heat rejection of 200 KJ/kg.
- Check whether this cycle follows **1<sup>st</sup>** law.

$$\text{Total } Q = \text{Total } W = 35 \text{ kJ/kg}$$



**RSET**  
RAJAGIRI SCHOOL OF  
ENGINEERING & TECHNOLOGY

# ***LENOIR CYCLE (PULSE JET ENGINE CYCLE)***

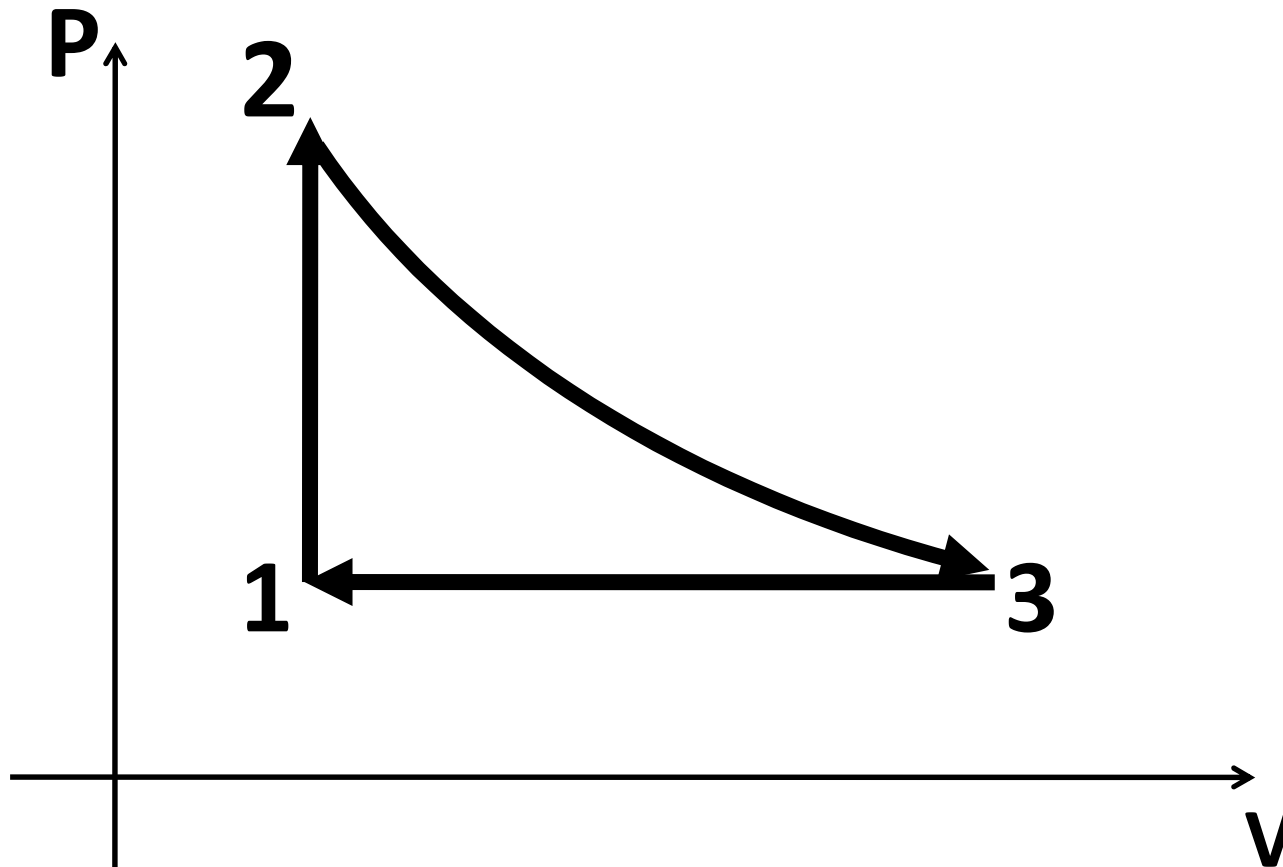



**RSET**  
RAJAGIRI SCHOOL OF  
ENGINEERING & TECHNOLOGY

# First law applied to open systems

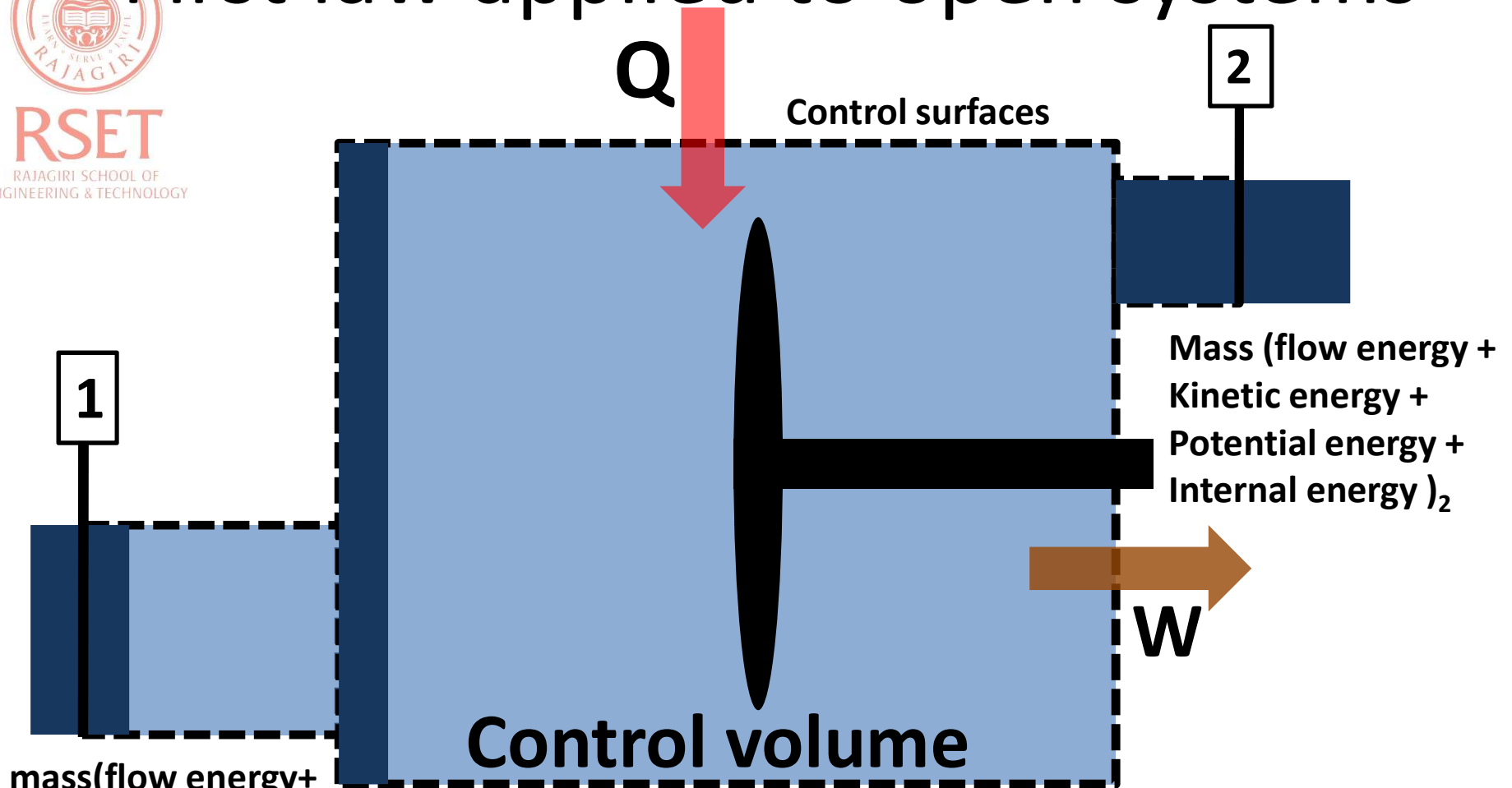

mass(flow energy+  
Kinetic energy +  
potential energy +  
internal energy)<sub>1</sub>

$$Q + m( FE + KE + PE + U )_1 = m( FE + KE + PE + U )_2 + W$$

In a continuous process let **m** be the amount of matter passing through the control volume in time **t** and **Q J** and **W J** be the amount of heat and work transfer in time **t**. then above equation becomes.

$$Q' + m'(FE+KE+PE+U)_1 = m'(FE+KE+PE+U)_2 + W' \text{ -----(SFEE)}$$

$m' = 1 \text{ kg/s}$   
 $v = 2 \text{ m/s}$   
 $P = 0.3 \text{ MPa}$   
 $\rho = 1 \text{ Kg/m}^3$   
 $A = 0.5 \text{ m}^2$   
 $U = 1400 \text{ kJ/kg}$

$m' = \rho A v \text{ kg/s} = \text{constant}$   
**Law of conservation of mass**

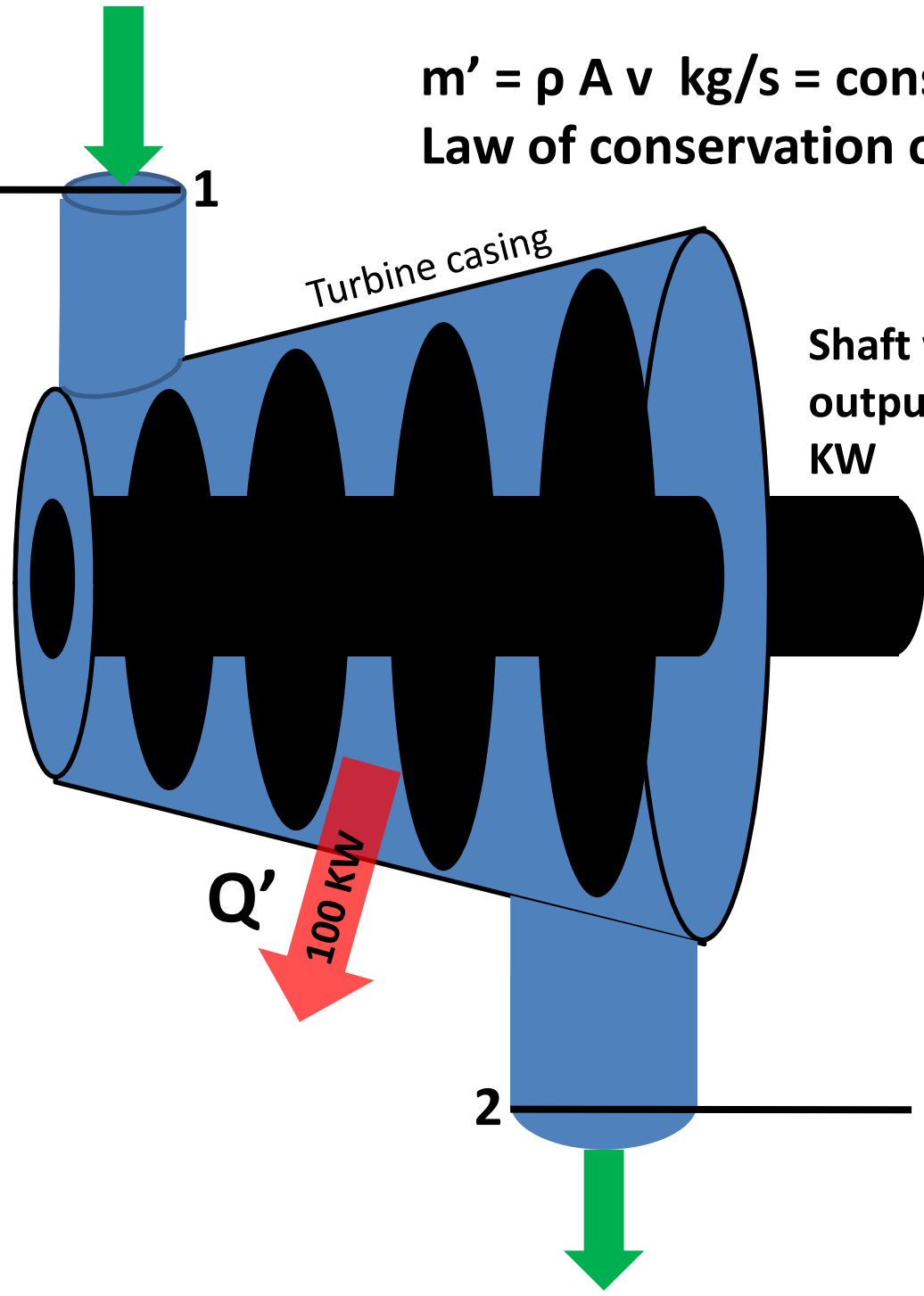

**Shaft work output in KW ?**

$m' = 1 \text{ kg/s}$   
 $v = 1 \text{ m/s}$   
 $P = 0.1 \text{ MPa}$   
 $\rho = 1 \text{ Kg/m}^3$   
 $A = 1 \text{ m}^2$   
 $U = 420 \text{ kJ/Kg}$

## Practice problem 7(p88)

- Air flows steadily at a rate of 0.5 kg/s through an air compressor at 7 m/s velocity, 100 kPa pressure and 0.95 m<sup>3</sup>/kg volume and leaving at 5 m/s, 700 kPa and 0.19 m<sup>3</sup>/kg. internal energy of air leaving is 90 kJ/kg greater than that of air entering. Cooling water in the compressor jackets absorbs heat from the air at the rate of 58 kW.
- Compute the rate of work input to the air in kW
- Find the ratio of inlet pipe diameter to outlet pipe diameter.

## Practice problem 8(p90)

- In a steady flow apparatus, 135 kJ of work is done by each kg of fluid. The specific volume of the fluid, pressure and velocity at the inlet are  $0.37 \text{ m}^3/\text{kg}$ , 600kPa and 16 m/s. The inlet is 32m above the floor and the discharge pipe is at the floor level. The discharge conditions are  $0.62 \text{ m}^3/\text{kg}$ , 100 kPa, and 270m/s. the total heat loss between inlet and discharge is 9kJ/kg of the fluid. In flowing through the apparatus, does the specific internal energy increases or decreases and by how much?



## Practice problem 9(p90)

- In a steam power station steam flows steadily through a 0.2 m diameter pipeline from the boiler to the turbine. At the boiler end, the steam conditions are found to be,  $P=4$  MPa,  $T=400^{\circ}\text{C}$  ,  $h$  (*specific enthalpy,  $u + P/\rho$* )= 3213.6 kJ/kg and  $v= 0.084$  m<sup>3</sup>/kg. there is a heat loss of 8.5 kJ/kg from the pipeline. Calculate the steam flow rate.

# Practice problem 10(p91)

- A certain water heater operates under steady flow conditions receiving 4.2 kg/s of water at 75°C temperature, enthalpy 313.93kJ/kg. the water is heated by mixing with steam which is supplied to the heater at temperature 100.2 °C and enthalpy 2676 kJ/kg. the mixture leaves the heater as liquid water at temperature 100°C and enthalpy 419 kJ/kg. how much steam must be supplied to the heater per hour?



**RSET**  
RAJAGIRI SCHOOL OF  
ENGINEERING & TECHNOLOGY

# ***SECOND LAW***



# CYCLIC DEVICES

- **Heat engine**-- is a device **working in a cycle** in which there is a **net heat transfer to the system** and **net work transfer from the system**.  
E.g. IC engines, power plants
- **Heat pump** – is a device **working in a cycle** in which there is a **net work transfer to the system** and **net heat transfer from the system**.

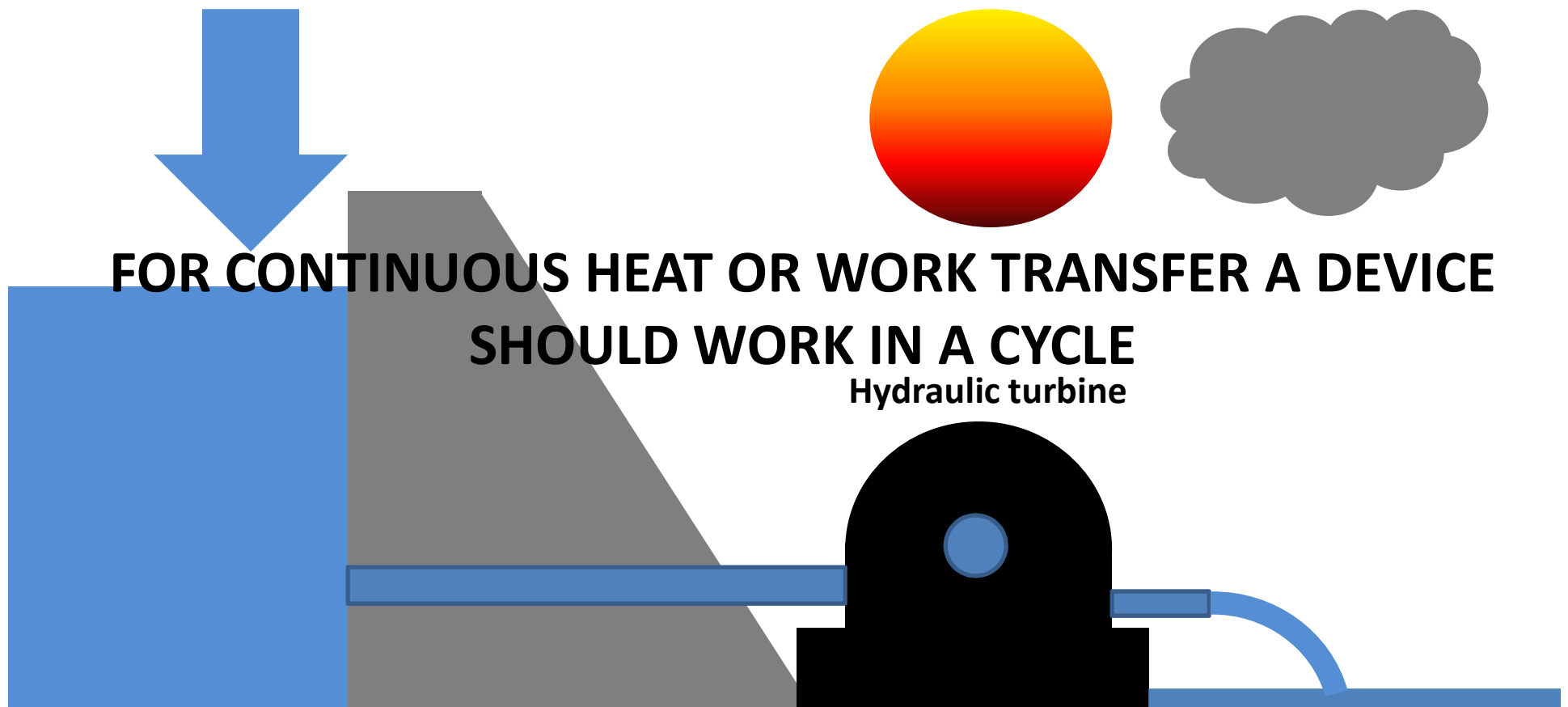

# HEAT ENGINE CYCLE e.g.

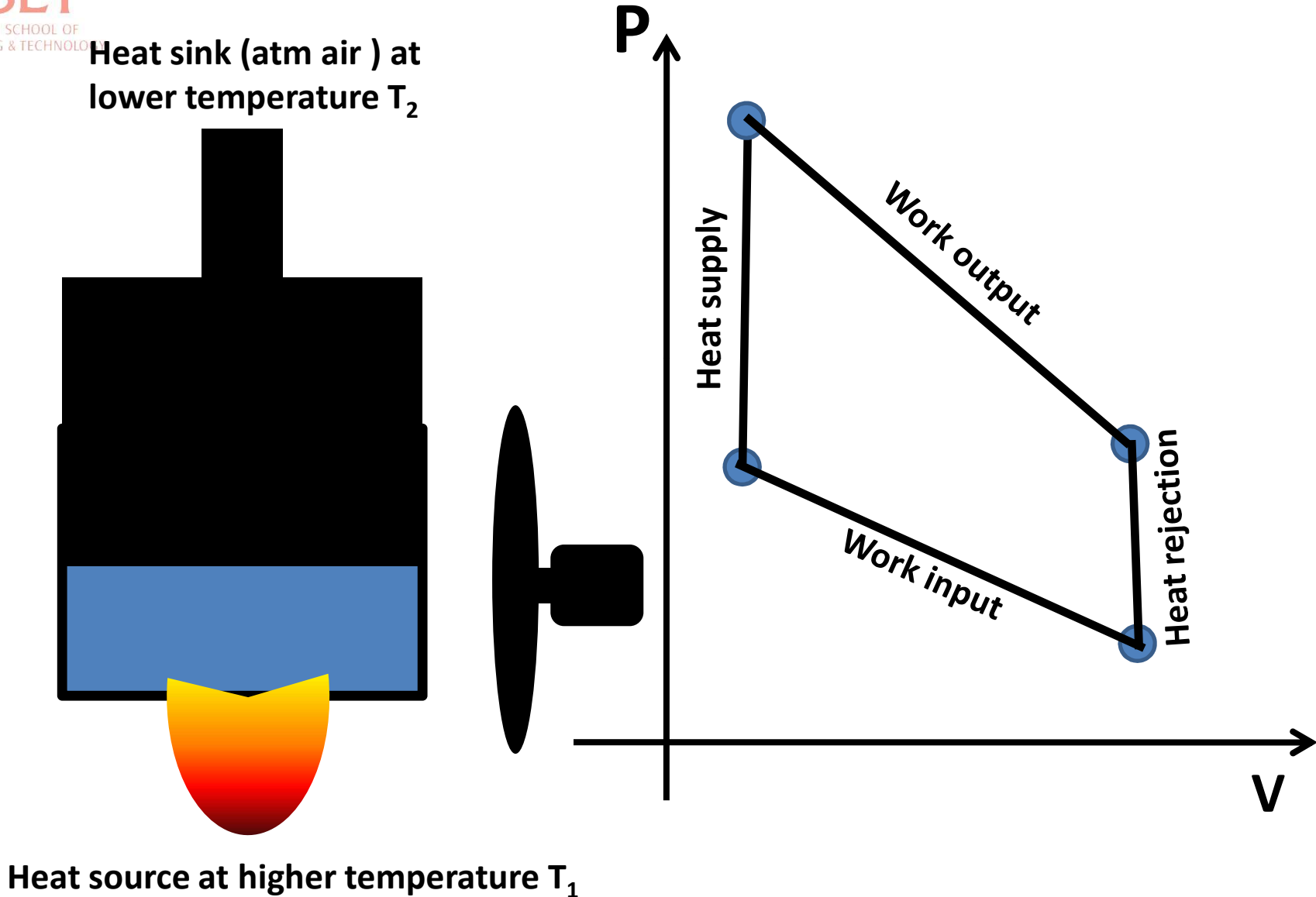



RSET

RAJAGIRI  
ENGINEERING & TECHNOLOGY

# ACTUAL OPERATION OF A PETROL ENGINE

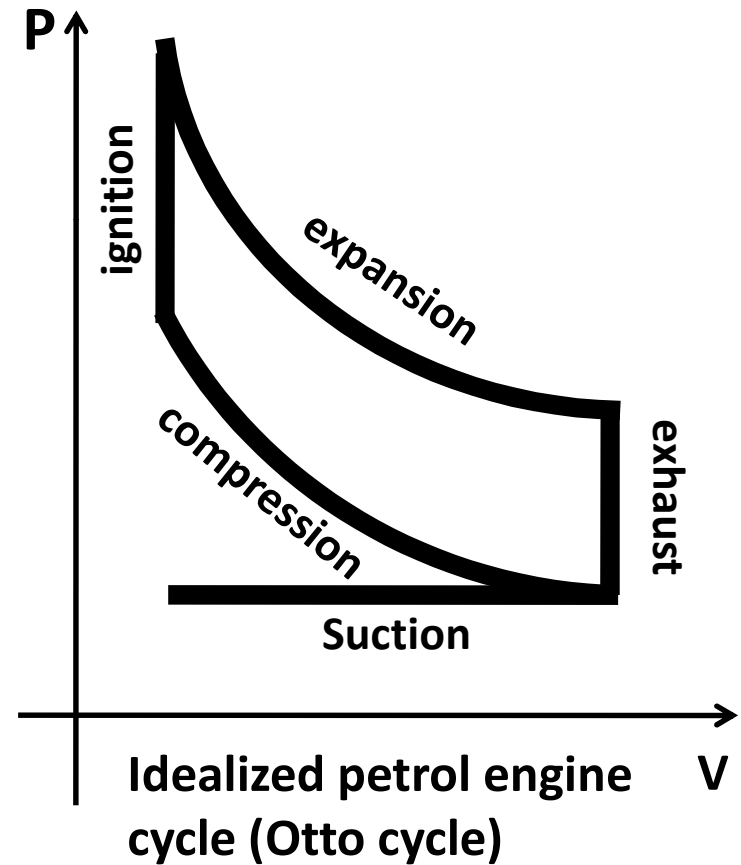
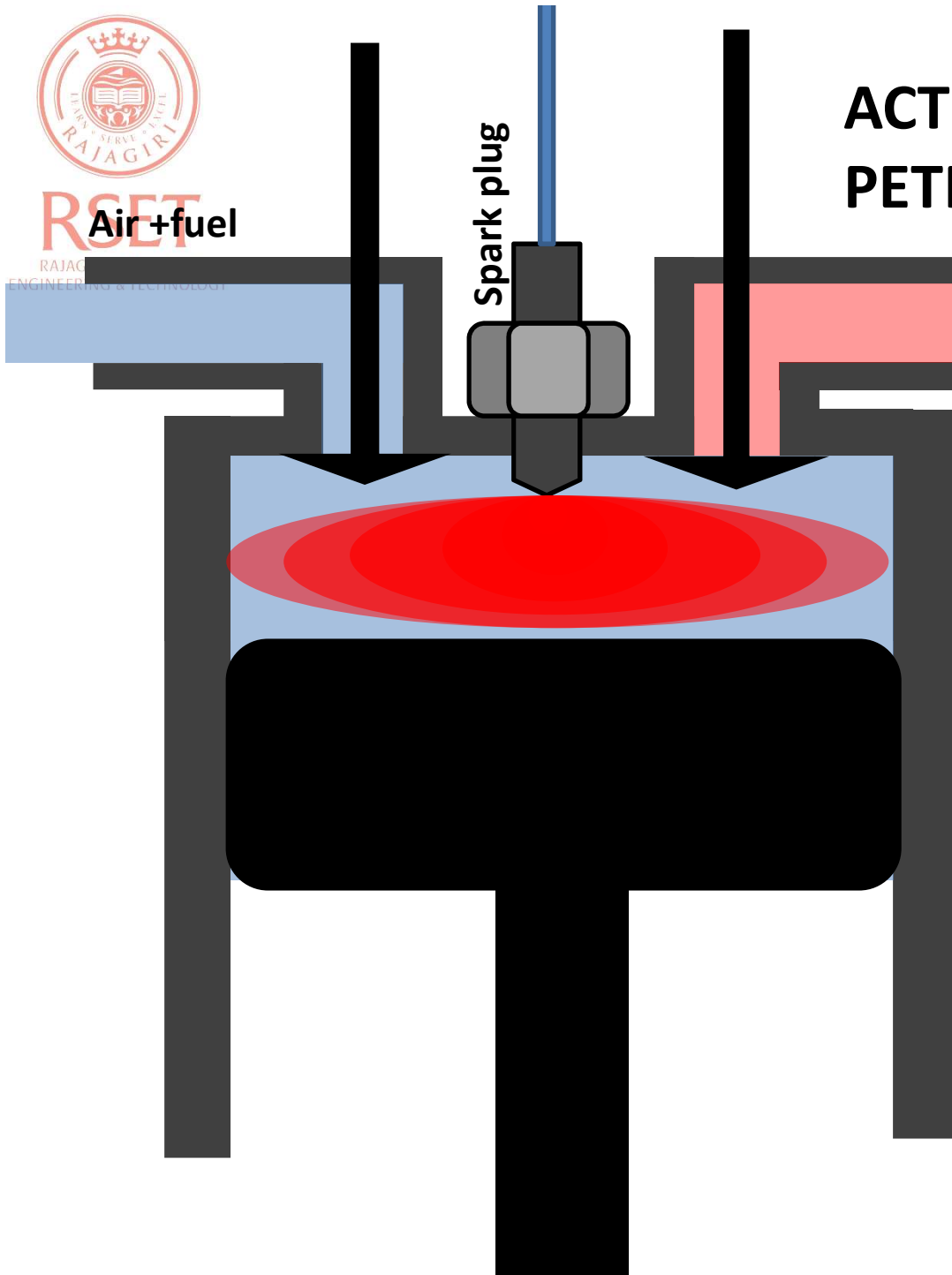

# HEAT PUMP CYCLE e.g.

Heat sink (room air) at lower temperature  $T_2$

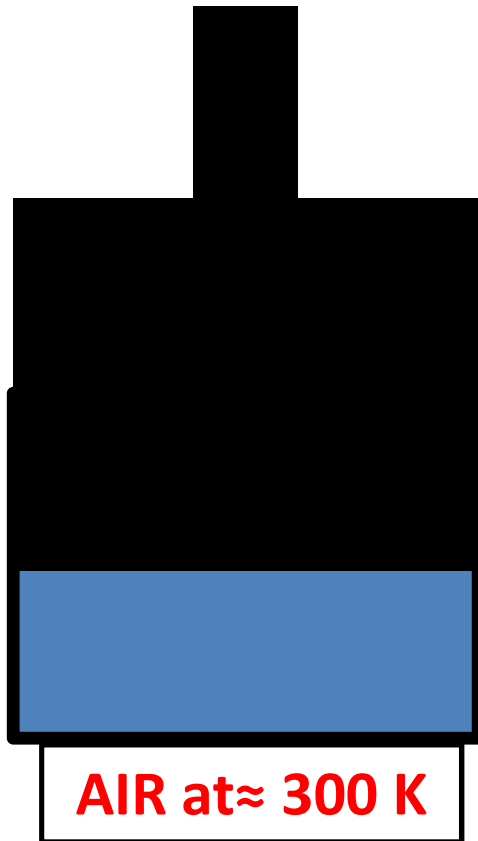

Heat source (atm air) at lower temperature  $T_1$

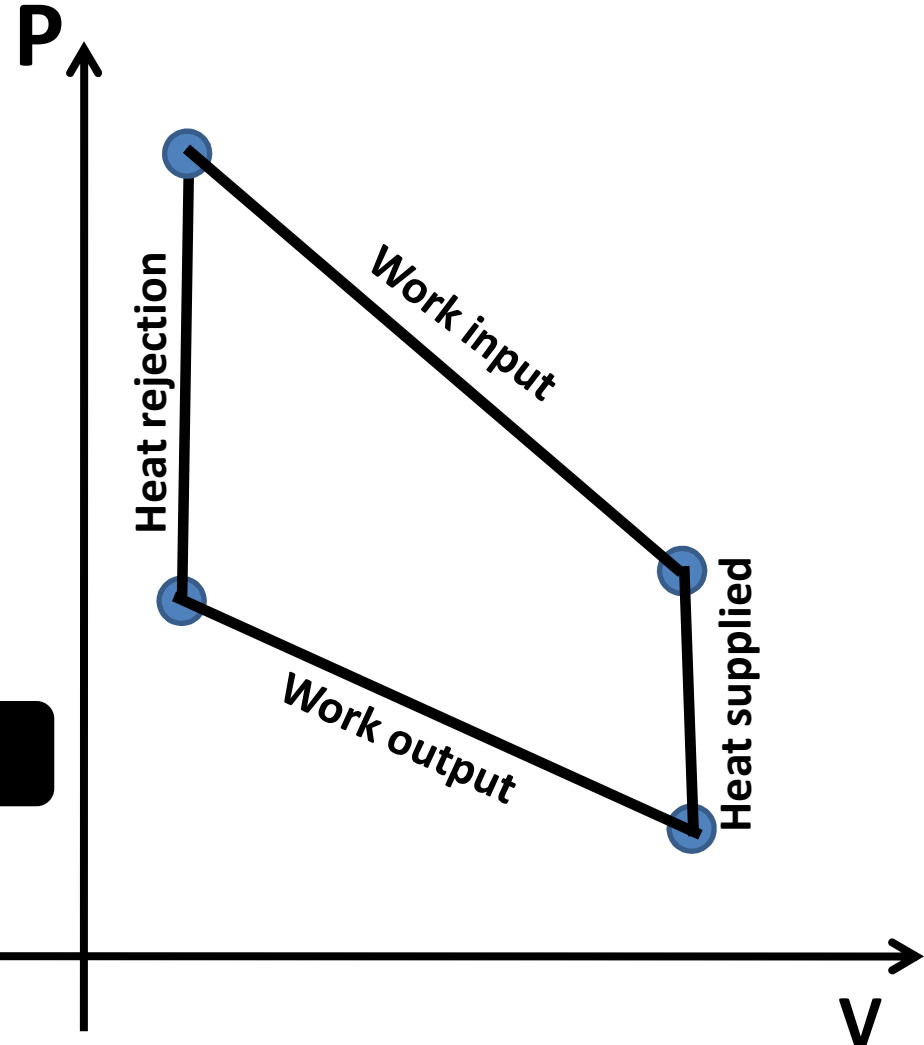



RSET

RAJAGIRI INSTITUTE OF  
ENGINEERING & TECHNOLOGY

# KELVIN PLANK STATEMENT OF SECOND LAW

- It is impossible for a heat engine to produce net work in a complete cycle. If it exchanges heat only with bodies at a single fixed temperatures.***

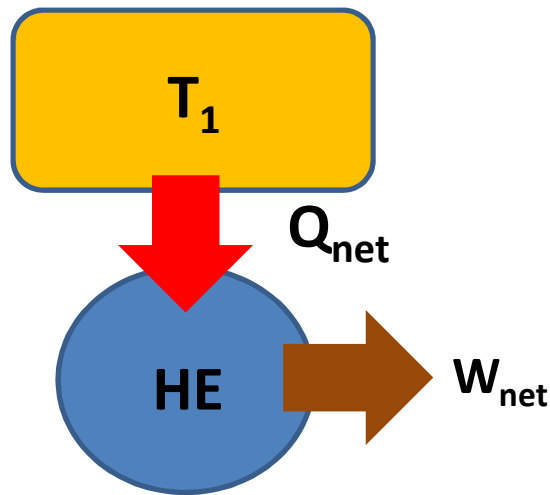

***Impossible according to second law.  
But possible according to the first law***

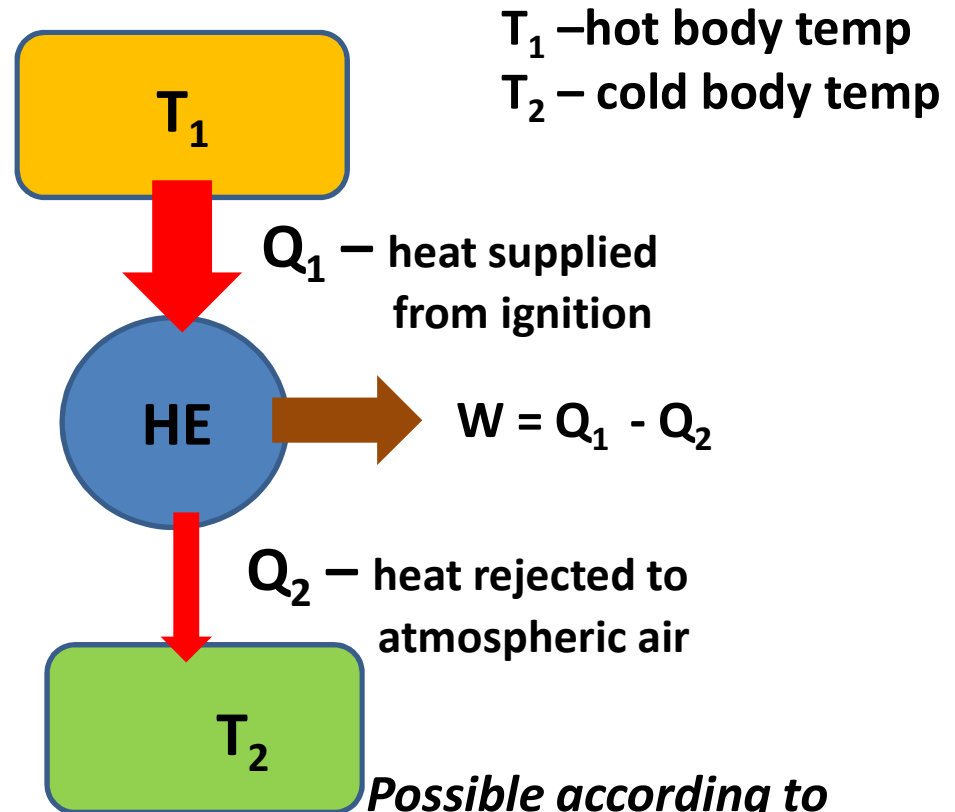

***Possible according to  
second law as well as first law***





**RSET**

RAJAGIRI SCHOOL OF  
ENGINEERING & TECHNOLOGY

# **PERFORMANCE PARAMETER OF HEAT ENGINES**

- Ratio of desired effect (net work output) to effort spent (heat supplied)
- Efficiency

$\eta = (\text{net work output} / \text{heat supplied})$  in a cycle

$$= W / Q_1$$

$$= (Q_1 - Q_2) / Q_1 = 1 - Q_2 / Q_1$$

from this we find that no heat engine can have 100% efficiency.

$W$  is also called **available energy** i.e. maximum possible net work that can be obtained from an engine.



RSET

RAJAGIRI SCHOOL OF  
ENGINEERING & TECHNOLOGY

# CLAUSIUS STATEMENT OF SECOND LAW

- It is impossible to construct a device which, operating in a cycle, will produce no effect other than the transfer of heat from a cooler to a hotter body.

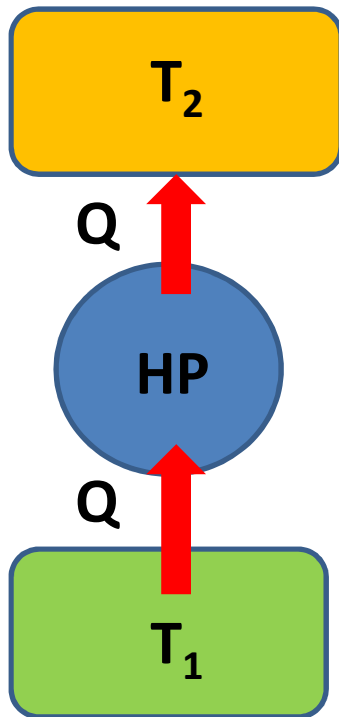

*Impossible according to second law.  
But possible according to the first law*

$T_1$  – cold body temp  
 $T_2$  – hot body temp

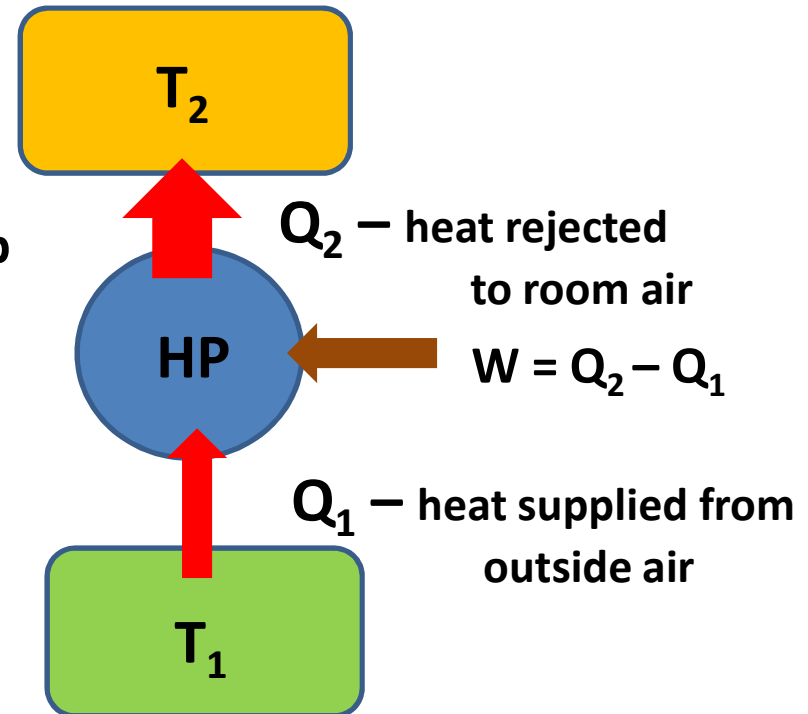

*Possible according to  
second law as well as first law*



**RSET**

RAJAGIRI SCHOOL OF  
ENGINEERING & TECHNOLOGY

# PERFORMANCE PARAMETER OF HEAT PUMPS

- Ratio of desired effect (heat supplied to room) to effort spent (net work input)
- Coefficient of performance,  
COP= (heat rejected by system/ net work input) in a cycle  
$$= Q_2 / W$$
$$= Q_2 / (Q_2 - Q_1 )$$

**from this we find that COP of heat pumps is always greater than unity.**



**RSET**

RAJAGIRI SCHOOL OF  
ENGINEERING & TECHNOLOGY

# EXPLAINING IRREVERSIBILITY USING SECOND LAW

- Heat transfer through a finite temperature difference.

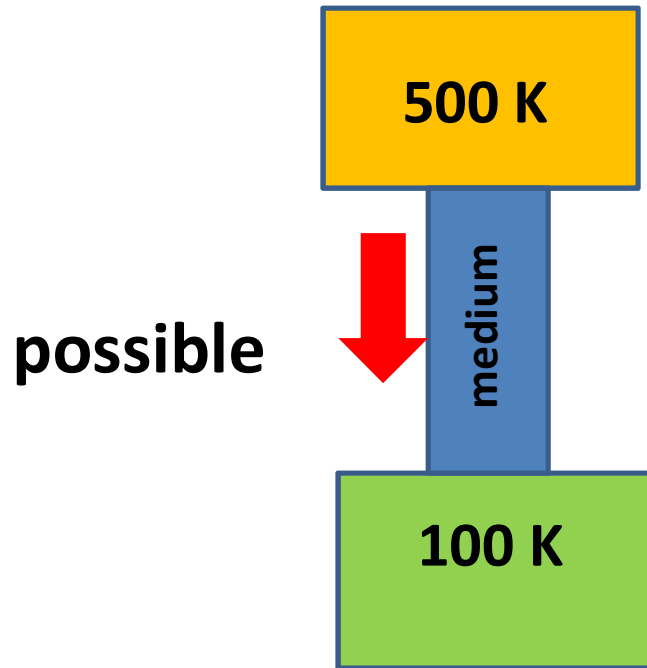

*So heat transfer through a finite temperature gradient is a spontaneous process*

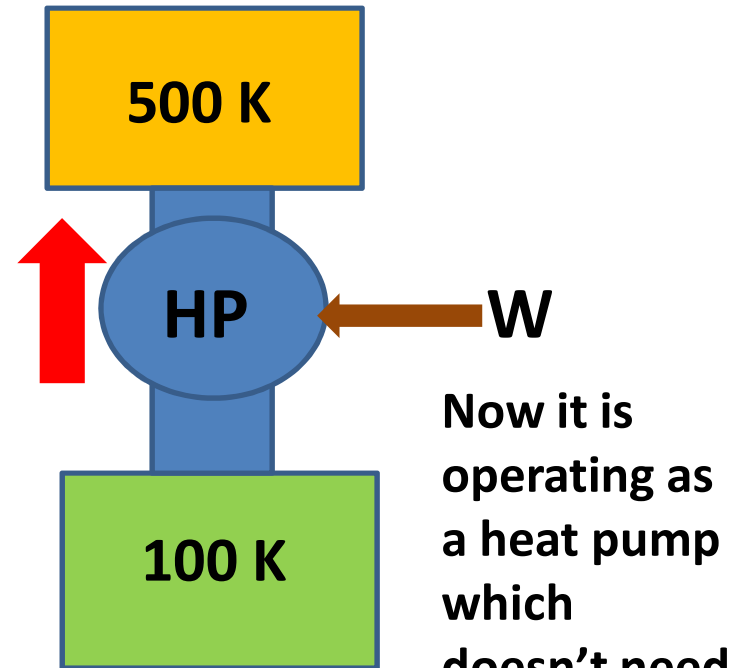

**Possible?**

Now it is operating as a heat pump which doesn't need work input.



RSET

RAJAGIRI SCHOOL OF  
ENGINEERING & TECHNOLOGY

# EFFICIENCY OF A CARNOT ENGINE CYCLE (A Reversible Cycle)

- Efficiency of a reversible heat engine in which heat is received *solely at temp  $T_1$*  from a heat source reservoir and heat is rejected *solely at temperature  $T_2$*  to a heat sink reservoir is given

by  $\eta = 1 - Q_2 / Q_1 = 1 - T_2 / T_1$

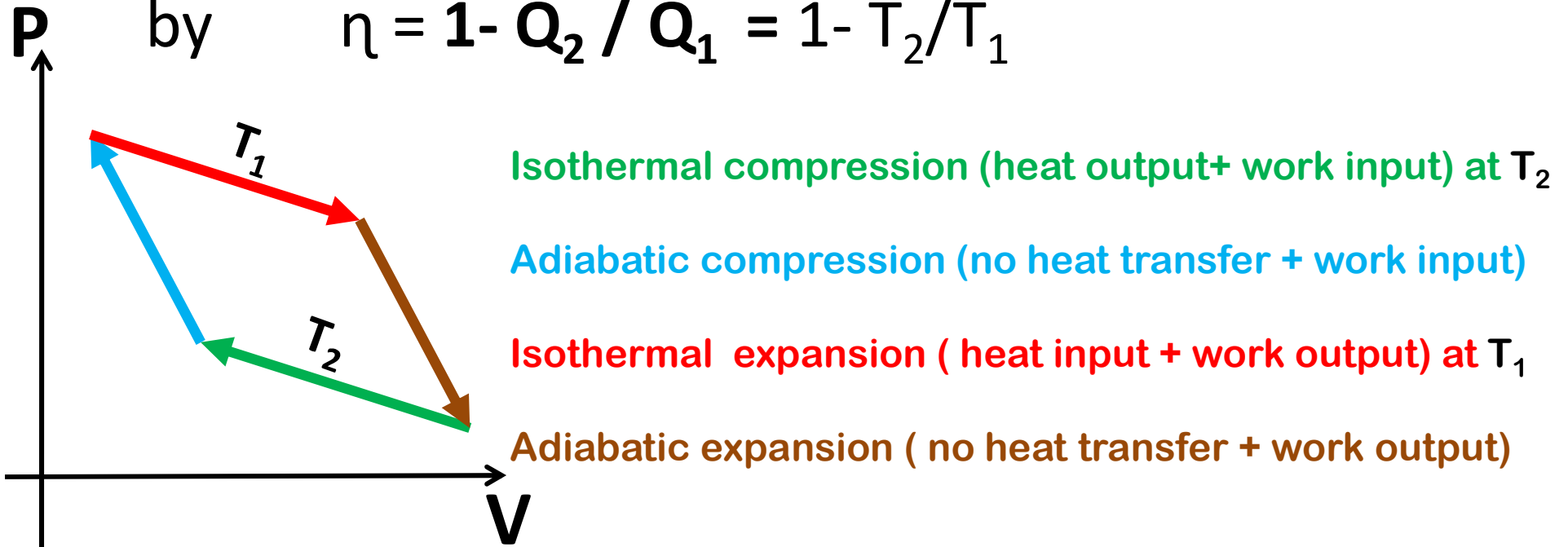



**RSET**

RAJAGIRI SCHOOL OF  
ENGINEERING & TECHNOLOGY

# ***SOURCE RESERVOIRS AND SINK RESERVOIRS EXAMPLES***

***Heat Source reservoir - is defined as a large body of infinite heat capacity which is capable of supplying an unlimited quantity of heat without change in temperature***

***E.g. Sun***



***Heat Sink reservoir - is defined as a large body of infinite heat capacity which is capable of absorbing an unlimited quantity of heat without change in temperature***

***E.g. atmospheric air.***

## Practice problem 11(p130)

- A cyclic heat engine operates between a source temperature of  $800^{\circ}\text{C}$  and sink temperature of  $30^{\circ}\text{C}$ . What is the least rate of heat rejection per net output of the engine in KW ? ***0.392 kW***

## Practice problem 12(p130)

- A domestic refrigerator maintains a temperature of  $-15^{\circ}\text{C}$ . The ambient air temperature is  $30^{\circ}\text{C}$ . If the heat leaks into the freezer at a continuous rate of  $1.75 \text{ kJ/s}$  what is the least power necessary to pump this heat out continuously? ***0.31 kW***



# Practice problem 13

- It is proposed that solar energy can be used to warm a large collector plate. This energy would in turn be transferred as heat to a fluid within a heat engine, and the engine would reject energy as heat to atmosphere. Experiments indicate that about  $1880 \text{ kJ/m}^2 \text{ h}$  of energy can be collected when the plate is operating at  $90^\circ\text{C}$ . Estimate the minimum collector area that would be required for a plant producing  $1\text{kW}$  of useful shaft power. Atmospheric temperature may be assumed to be  $20^\circ\text{C}$ .  **$10 \text{ m}^2$**

# Practice problem 14

- A reversible heat engine in a satellite operates between a hot reservoir at  $T_1$ . and a radiating panel at  $T_2$  . The radiation from the panel is proportional to its area and to  $T_2^4$  . For a given work output and value of  $T_1$  show that the area of the panel will be minimum when  $T_2/T_1 = 0.75$ .
- Determine the minimum area of the panel for an output of 1 kW if the constant of proportionality is  $5.67 \times 10^{-8} \text{ W/m}^2 \text{ K}^4$  and  $T_1 = 1000\text{K}$ .

***0.1672 m<sup>2</sup>***

# ***GRADES OF ENERGY***

## **High Grade energy**

Mechanical work

(Because in a heat pump all of the mechanical work can be converted to heat energy)

Electric energy

Water power

Wind power

Kinetic energy of a jet

Tidal power

**The bulk of high grade energy is obtained from sources of low grade energy  
Complete conversion of low grade energy to high grade energy is impossible by  
second law**

## **Low grade energy**

Heat or thermal

( because in a heat engine a portion of heat energy is available as net work- second law)

Heat derived from nuclear fission or fusion

Heat derived from the combustion of fossil fuels



**RSET**  
RAJAGIRI SCHOOL OF  
ENGINEERING & TECHNOLOGY

# ***ENTROPY***

**(Measure of irreversibility of process)**



• **Efficiency of a Carnot cycle,**

$$\eta = 1 - Q_2 / Q_1 = 1 - T_2 / T_1$$

$Q_1$  - Heat supplied to engine

$T_1$  - Constant temperature  
at which heat is supplied

$Q_2$  - Heat rejected by engine

$T_2$  - Constant temperature  
at which heat is rejected

$$Q_2 / Q_1 = T_2 / T_1$$

$$Q_1 / T_1 = Q_2 / T_2$$

$$Q_1 / T_1 - Q_2 / T_2 = 0$$

$\sum_{\text{cycle}} Q/T = 0$  for a Carnot engine cycle.

i.e.  $\oint \frac{\delta Q}{T} = 0$  ( for a Carnot engine cycle)

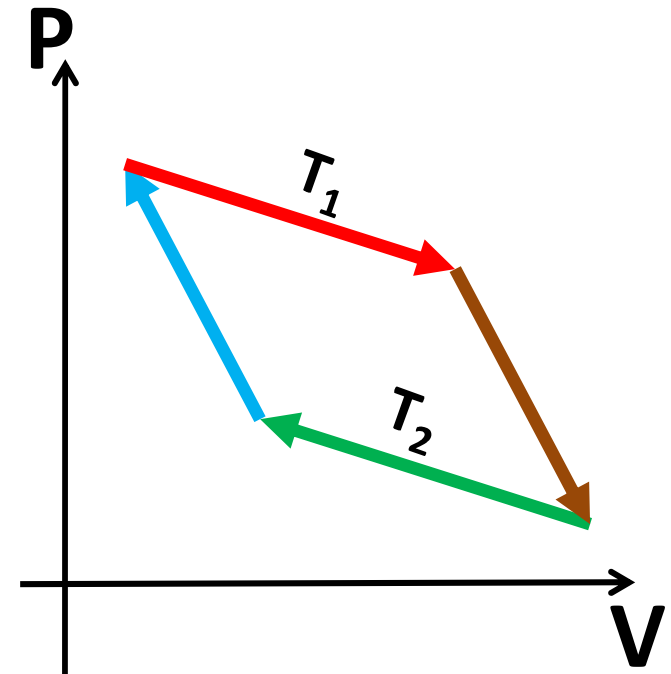

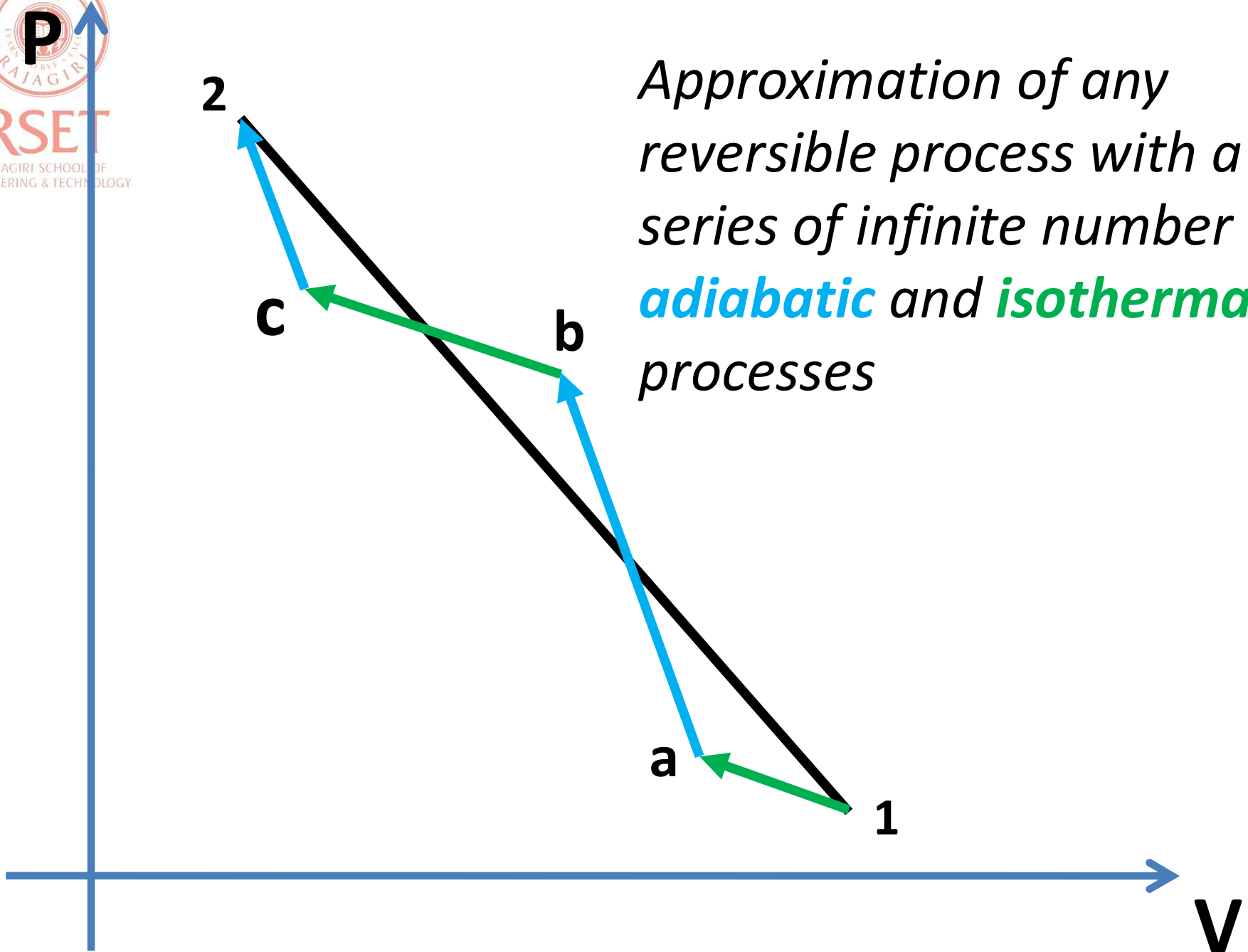

Approximation of any reversible process with a series of infinite number of **adiabatic** and **isothermal** processes

## Considering any reversible cycle

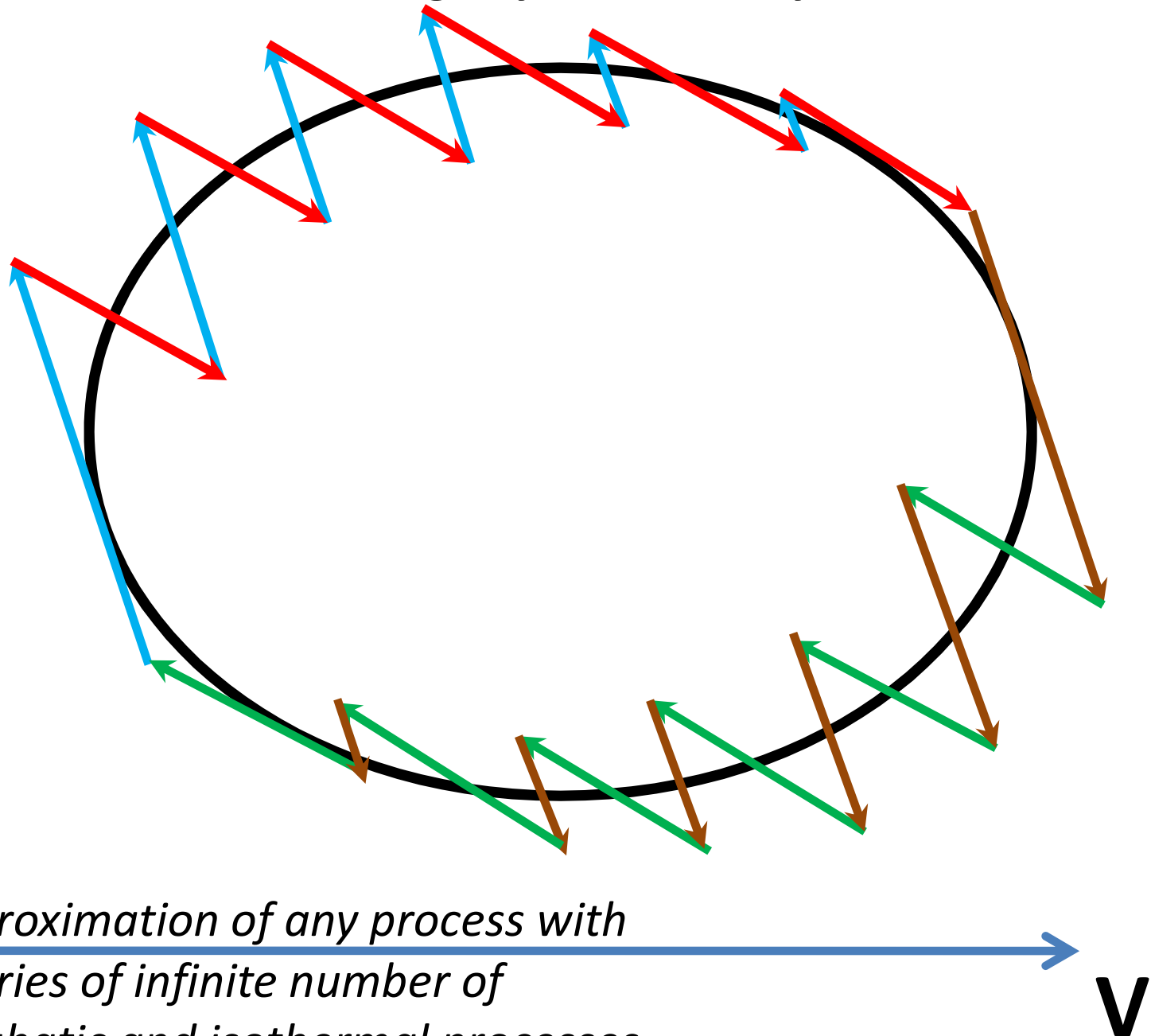

*Approximation of any process with  
a series of infinite number of  
adiabatic and isothermal processes*



**RSET**

RAJAGIRI SCHOOL OF  
ENGINEERING & TECHNOLOGY

- So for this reversible cycle also we can write

$$\oint \frac{\delta Q}{T} = 0 \quad (\text{for a reversible cycle})$$

- We know that cyclic integral of any property = 0
- So  $\frac{\delta Q}{T}$  is a property, this property we call *Entropy S*.

- $\delta Q = T dS$

- $Q = \int T ds$  (area under *T-S curve*)  
for a reversible process.

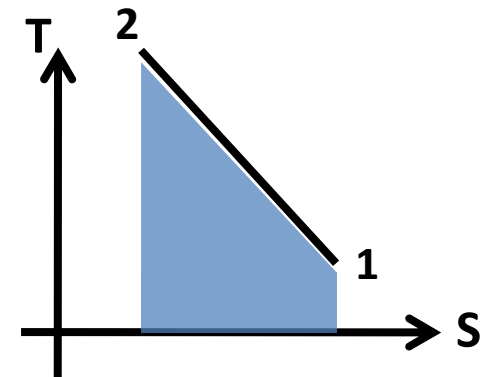



# CLAUSIUS INEQUALITY

$$\oint \frac{\delta Q}{T} = 0 \quad (\text{for a reversible cycle})$$

$$\oint \frac{\delta Q}{T} < 0 \quad (\text{for an irreversible cycle})$$

$$\oint \frac{\delta Q}{T} > 0 \quad (\text{for an impossible cycle, since it violates second law})$$



**RSET**  
RAJAGIRI SCHOOL OF  
ENGINEERING & TECHNOLOGY

# ENTROPY CHANGE DURING A PROCESS

- For a reversible process,

$$S_2 - S_1 = \int \frac{\delta Q}{T}$$

$$dS = \frac{\delta Q}{T}$$

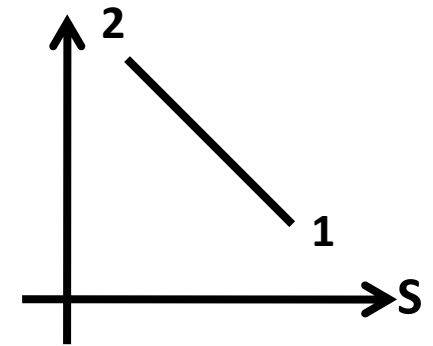

- For an irreversible process,

$$S_2 - S_1 > \int \frac{\delta Q}{T}$$

$$dS > \frac{\delta Q}{T}$$

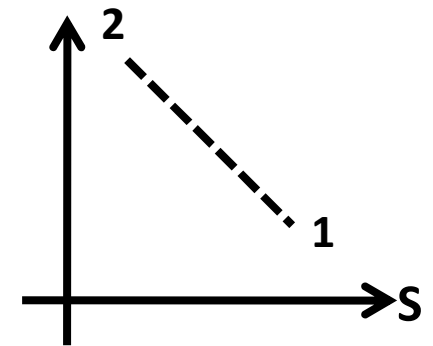

- For an impossible process,

$$S_2 - S_1 < \int \frac{\delta Q}{T}$$

$$dS < \frac{\delta Q}{T}$$

, since it violates second law)



RSET

RAJAGIRI SCHOOL OF  
ENGINEERING & TECHNOLOGY

# PRINCIPLE OF INCREASE OF ENTROPY

- For any process we can write  $dS \geq \delta Q/T$
- For an isolated system, there is no energy transfer to or from the system so  $\delta Q=0$
- So  $dS \geq 0$  for an isolated system
- A system comprising of both **system** and **surrounding** is called isolated system or a universe
- i.e  $(dS)_{universe} \geq 0$
- $(dS)_{system} + (dS)_{surrounding} \geq 0$
- $\Delta S_{system} + \Delta S_{surrounding} \geq 0$
- **i.e Entropy of an isolated system or universe will never decrease.**
- for a **reversible process**  $(dS)_{universe} = 0$   
i.e.  $\Delta S_{system} + \Delta S_{surrounding} = 0$



RSET

RAJAGIRI SCHOOL OF  
ENGINEERING & TECHNOLOGY

# EXPLAINING IRREVERSIBILITY USING ENTROPY PRINCIPLE

- Heat transfer through a finite temperature difference

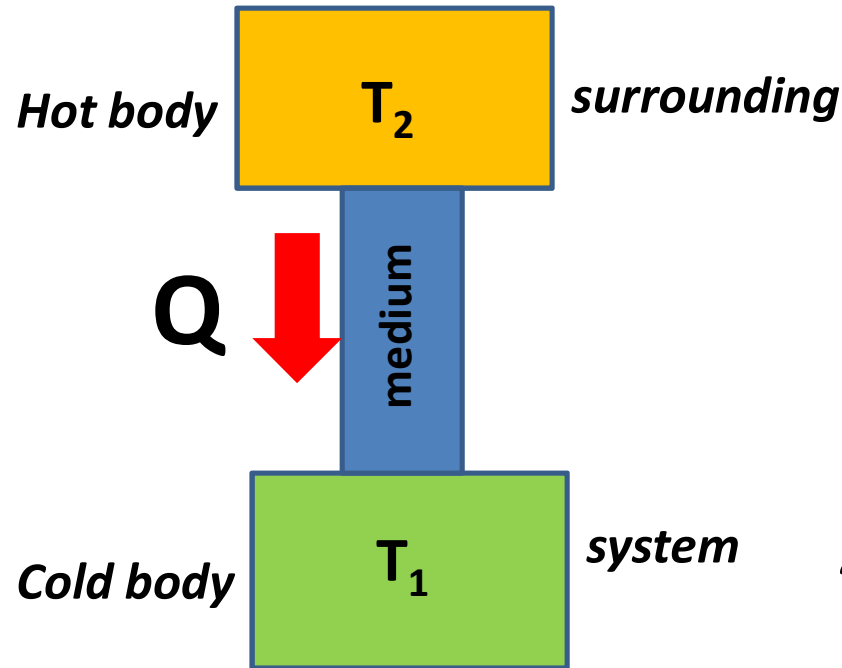

*So heat transfer through a finite temperature gradient is a spontaneous process*

*Entropy change of the system,*

$$\Delta S_{\text{system}} = Q / T_1$$

*Entropy change of the surrounding,*

$$\Delta S_{\text{surroundings}} = -Q / T_2$$

*Entropy change of the universe,*

$$\Delta S_{\text{system}} + \Delta S_{\text{surroundings}} = Q (T_2 - T_1) / (T_1 T_2) > 0$$

*Conversely if we consider Q flowing from  $T_1$  to  $T_2$ , we will get  $\Delta S_{\text{universe}} < 0$  which makes it an impossible process*

## Practice problem 15(p171)

- One kg of water is brought in contact with a heat reservoir at 373K. When the water has reached 373 K, find the entropy change of water, the heat reservoir and of the universe. (*take specific heat,  $c$  of the water as 4.187 kJ/kg K*) **0.183 kJ/K**
- If water is heated from 273 to 373 K by first bringing it in contact with a reservoir at 323 K and then with a reservoir at 373 K, what will the entropy change of the universe be? **0.098 kJ/K**
- How will you propose to heat the water from 273 to 373 K to make it a reversible process ?

# WHY WE ARE BOTHERED TO MAKE A PROCESS REVERSIBLE ?

- *Carnot's theorem- states that all heat engines operating between a given constant temperature source and a given constant temperature sink none has a higher efficiency than a reversible engine.*
- *Available work,  $W_{net}$  from a cyclic engine decreases with irreversibility.*



**RSET**  
RAJAGIRI SCHOOL OF  
ENGINEERING & TECHNOLOGY

# ***AVAILABILITY***

***(The reason we are bothered  
about irreversibility)***



**RSET**  
RAJAGIRI SCHOOL OF  
ENGINEERING & TECHNOLOGY

# ***RELATION BETWEEN AVAILABILITY AND ENTROPY***



# A REVERSIBLE ISOTHERMAL PROCESS

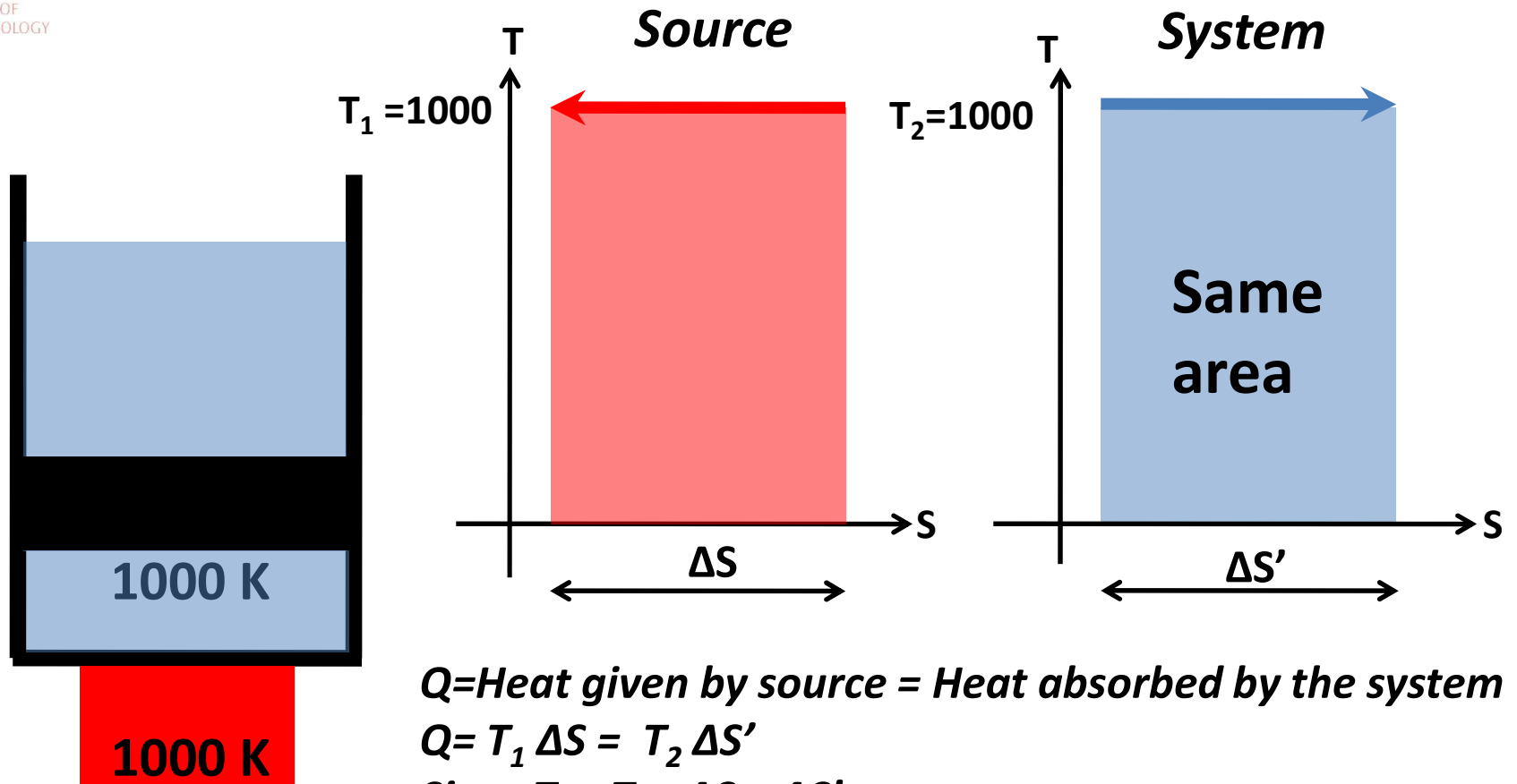



**RSET**

RAJAGIRI SCHOOL OF  
ENGINEERING & TECHNOLOGY

# AN IRREVERSIBLE ISOTHERMAL PROCESS

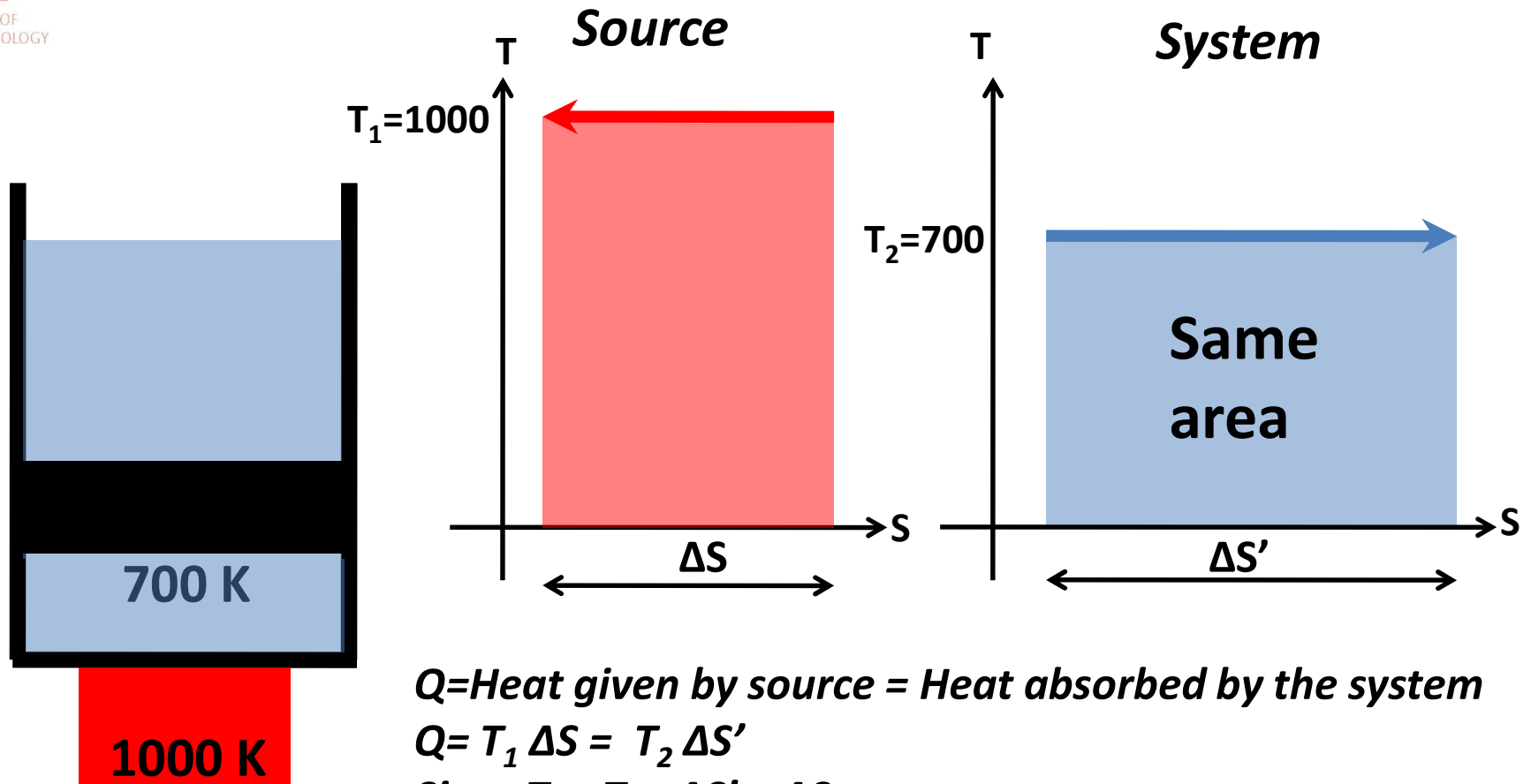

# AVAILABLE WORK FROM A REVERSIBLE CARNOT CYCLE

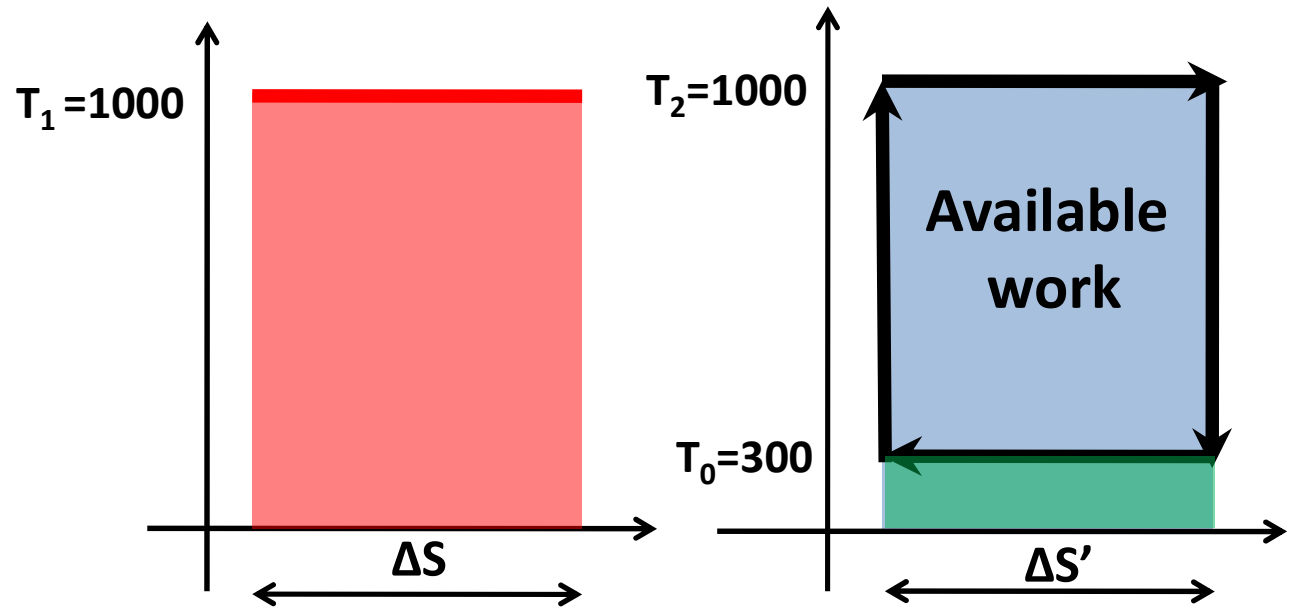
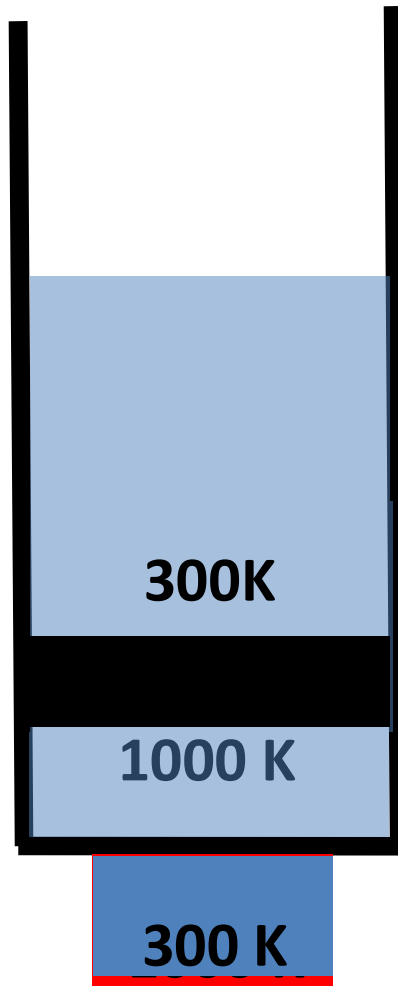

*Let Heat given by source = Heat absorbed by the system*  
 $= Q_i = 14000 \text{ J}$

*i.e.  $Q_i = T_1 \Delta S = T_2 \Delta S' = 14000 \text{ J}$*

*$\Delta S = 14 \text{ J/K}$  and  $\Delta S' = 14 \text{ J/K}$*

*In this case heat rejected  $Q_o = T_o \Delta S' = 4200 \text{ J}$*

*In this case  $W = Q_i - Q_o = 14000 - 4200 = 9800 \text{ J}$*

# AVAILABLE WORK FROM AN IRREVERSIBLE CARNOT CYCLE

**AVAILABILITY DECREASES WITH IRREVERSIBILITY**

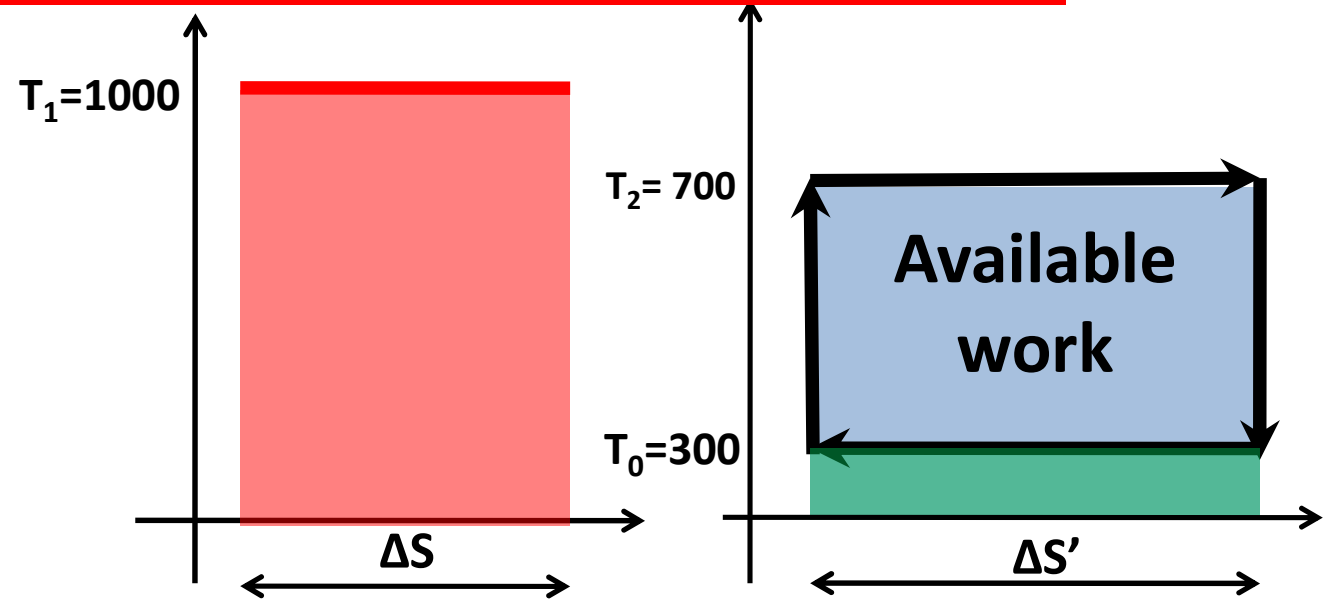
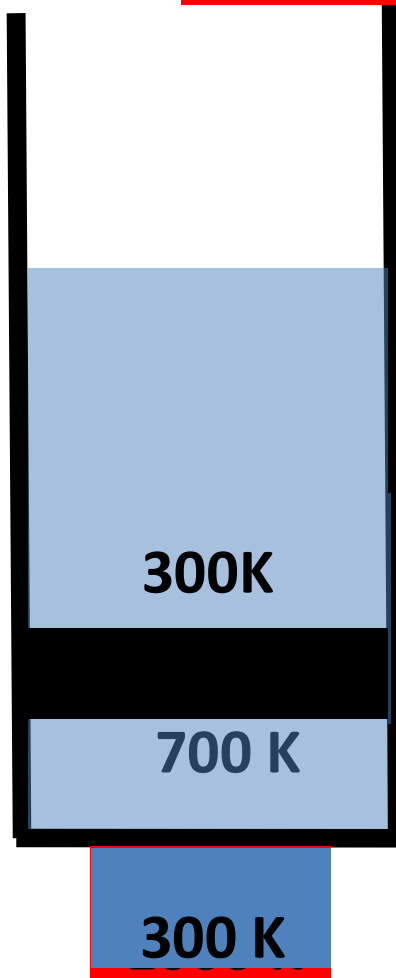

*Let Heat given by source = Heat absorbed by the system*

$$= Q_i = 14000 \text{ J}$$

$$\text{i.e. } Q_i = T_1 \Delta S = T_2 \Delta S' = 14000 \text{ J}$$

$$\Delta S = 14 \text{ J/K and } \Delta S' = 20 \text{ J/K}$$

*In this case heat rejected  $Q_o = T_o \Delta S' = 6000 \text{ J}$*

$$\text{In this case } W = Q_i - Q_o = 14000 - 6000 = \mathbf{8000 \text{ J}}$$

## Practice problem 16(p227)

- In a certain process, a vapor while condensing at  $420^{\circ}\text{C}$ , transfer heat to water evaporating at  $250^{\circ}\text{C}$ . The resulting steam is used in a power cycle which rejects heat at  $35^{\circ}\text{C}$ . What is the fraction of available energy in the heat transferred from the process vapor at  $420^{\circ}\text{C}$  that is lost due to irreversible heat transfer at  $250^{\circ}\text{C}$  ? **0.26**



**RSET**

RAJAGIRI SCHOOL OF  
ENGINEERING & TECHNOLOGY

# ***IDEAL GAS AND REAL GAS EQUATIONS***



RSET

RAJAGIRI SCHOOL OF  
ENGINEERING & TECHNOLOGY

# Ideal gas equation

Derived from experiments at macroscopic level

- Avogadro's law- Equal volumes of all gases under similar conditions of temperature and pressure contains equal no of molecules, (one mole of any gas at 1 atm and 273K occupies a volume of 22.4L)  
 $V \propto n$  (at constant T and P)
- Boyle's Law –  $V \propto 1/P$  (at constant absolute T and n)
- Charle's Law –  $V \propto T$  (at constant absolute P and n)
- i.e.  $P V \propto n T$ ,
- $PV = n R' T$
- which leads to constant of proportionality,  **$R'$ - universal gas constant.**
- $R' = PV / nT = 1 \text{ atm } 22.4\text{L} / 1\text{mole } 273\text{K} = 8.314 \text{ kJ/kmole K}$
- **$Pv' = R'T$**  where  $v'$  is molar specific volume  $\text{m}^3/\text{kmol}$
- **$P V = m R T$**  R-characteristic gas constant =  $R'/\text{Molecular mass}$
- **A hypothetical gas which obeys the general gas equation at all ranges of temperatures and pressures is called an ideal gas.**



**RSET**  
RAJAGIRI SCHOOL OF  
ENGINEERING & TECHNOLOGY

# **KINETIC MOLECULAR(MICROSCOPIC) THEORY**

## **FOR EXPLAINING IDEAL BEHAVIOR (FROM WIKIPEDIA)**

- The gas consists of very small particles known as molecules. This smallness of their size is such that the total [volume](#) of the individual gas molecules added up is negligible compared to the volume of the smallest open ball containing all the molecules. This is equivalent to stating that the average distance separating the gas particles is large compared to their [size](#).
- These particles have the same [mass](#).
- The number of molecules is so large that statistical treatment can be applied.
- These molecules are in constant, [random](#), and rapid motion.
- The rapidly moving particles constantly collide among themselves and with the walls of the container. All these collisions are perfectly elastic. This means, the molecules are considered to be perfectly spherical in shape, and elastic in nature.
- Except during collisions, the [interactions](#) among molecules are negligible. (That is, they exert no [forces](#) on one another.)
- The average [kinetic energy](#) of the gas particles depends only on the [absolute temperature](#) of the [system](#). The kinetic theory has its own definition of temperature, not identical with the thermodynamic definition.
- The time during collision of molecule with the container's wall is negligible as compared to the time between successive collisions.
- Because they have mass, the gas molecules will be affected by gravity.



# CAUSES OF DEVIATION OF A REAL GAS FROM IDEAL BEHAVIOR

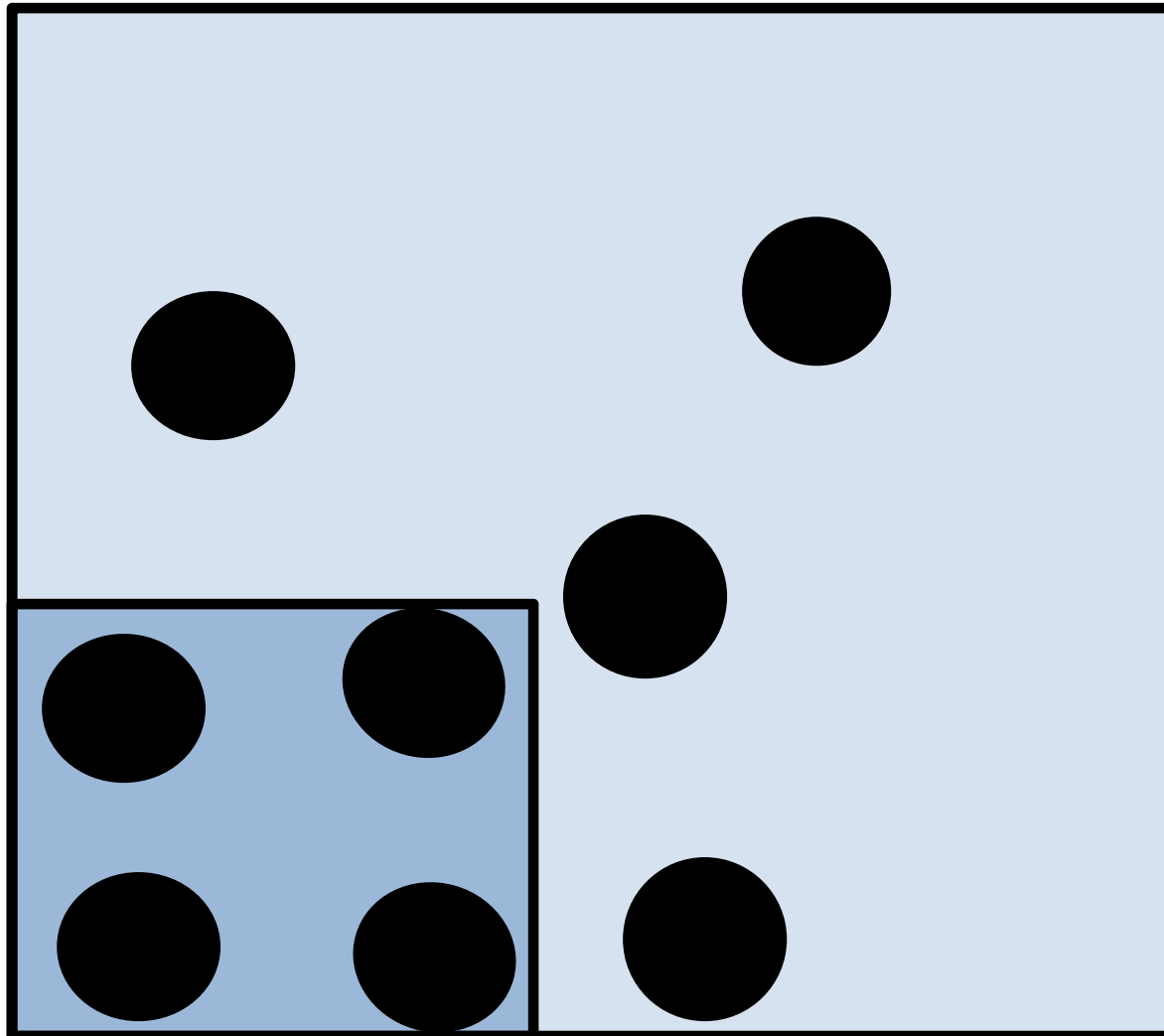

**At high temperature and low pressure**

• Total volume of individual molecules negligible

• Intermolecular attraction or repulsion negligible

**At high pressure and low temperature**

• Total volume of individual molecules significant

• Intermolecular attraction or repulsion significant

# A REAL GAS EQUATION

## **Van der Waals gas equation**

- **$(P + a/v'^2)(v'-b) = R' T$  or  $(P + a/v^2)(v-b) = R T$**
- *P is absolute pressure in Pa*
- *v'- molar specific volume m<sup>3</sup>/kmol*
- *v- specific volume m<sup>3</sup>/kg*
- *a/v'<sup>2</sup>- force of cohesion*
- *b- co-volume*
- *R'- universal gas constant-8.314 kJ/kmol K*
- *R- characteristic gas constant-  **$R' / \text{molecular mass in kg/kmol}$***
- *Real gas conforms more closely with van der Waals Equation of state, particularly at higher pressures, but is not obeyed at all ranges of pressure and temperatures.*



RSET

RAJAGIRI SCHOOL OF  
ENGINEERING & TECHNOLOGY

# ***COMPRESSIBILITY FACTOR***

- $Z = Pv'/R'T$
- Z- compressibility factor
- P- absolute pressure, Pa
- $v'$ - molar specific volume,  $m^3/mol$
- $R'$ - universal gas constant, 8.314 J/mol K
- T- absolute temperature, K
- For an ideal gas  $Z=1$
- But for real gas  $Z \neq 1$ ,

Real gas equation can be used that time but we need detailed data like value of ***a*** and ***b***.

- when detailed data on a particular gas is not available we can use experiment data charts called "***Generalized Compressibility chart***".



**RSET**

RAJAGIRI SCHOOL OF  
ENGINEERING & TECHNOLOGY

# ***GENERALIZED COMPRESSIBILITY CHART***

- Reduced property of a substance is the ratio of a property to its critical property.
- Reduced pressure  $P_r = P/P_c$
- Reduced temperature  $T_r = T/T_c$
- Reduced molar specific volume  $v'_r = v'/v'_c$
- Reduced specific volume  $v_r = v/v_c$
- Where subscript C denotes critical point (pressure and temperature at which latent heat=0) which is a unique property for a substance.
- Compressibility factor  **$Z = P v'/R' T$  or  $Z = P v/R T$**
- Plot of  **$Z$**  versus  **$P_r$**  for different values of  **$T_r$**  for different gases is called Generalized compressibility chart.
- ***A single Generalized compressibility chart can be used for almost all gases.***



RSET

RA  
ENGIN

# GENERALIZED COMPRESSIBILITY CHART

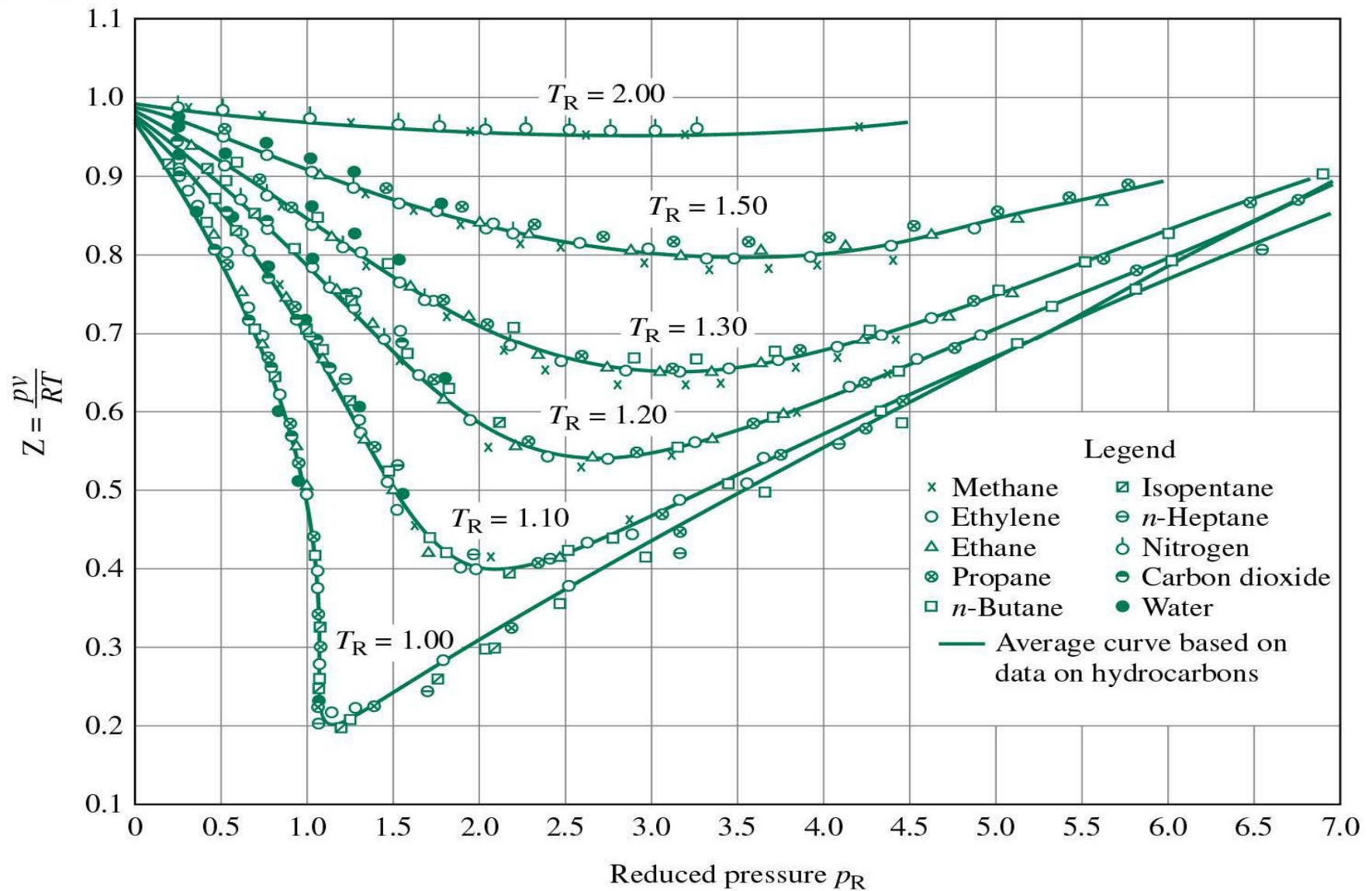

## Practice problem 17(p346)

- *A gas Neon has a molecular weight of 20.183 kg/kmol and its critical temperature, pressure and volume are 44.5 K, 2.73 MPa and 0.0416 m<sup>3</sup>/kg mol. [Reading from the compressibility chart given for a reduced pressure of 2 and a reduced temperature of 1.3, the compressibility factor Z is 0.7]. what are the corresponding specific volume, pressure, temperature and reduced volume?*

$$P= 5.46 \text{ MPa}, T= 57.85 \text{ K}, v=3.05 \times 10^{-3} \text{ m}^3/\text{kg}, v_r=1.48$$



**RSET**  
RAJAGIRI SCHOOL OF  
ENGINEERING & TECHNOLOGY

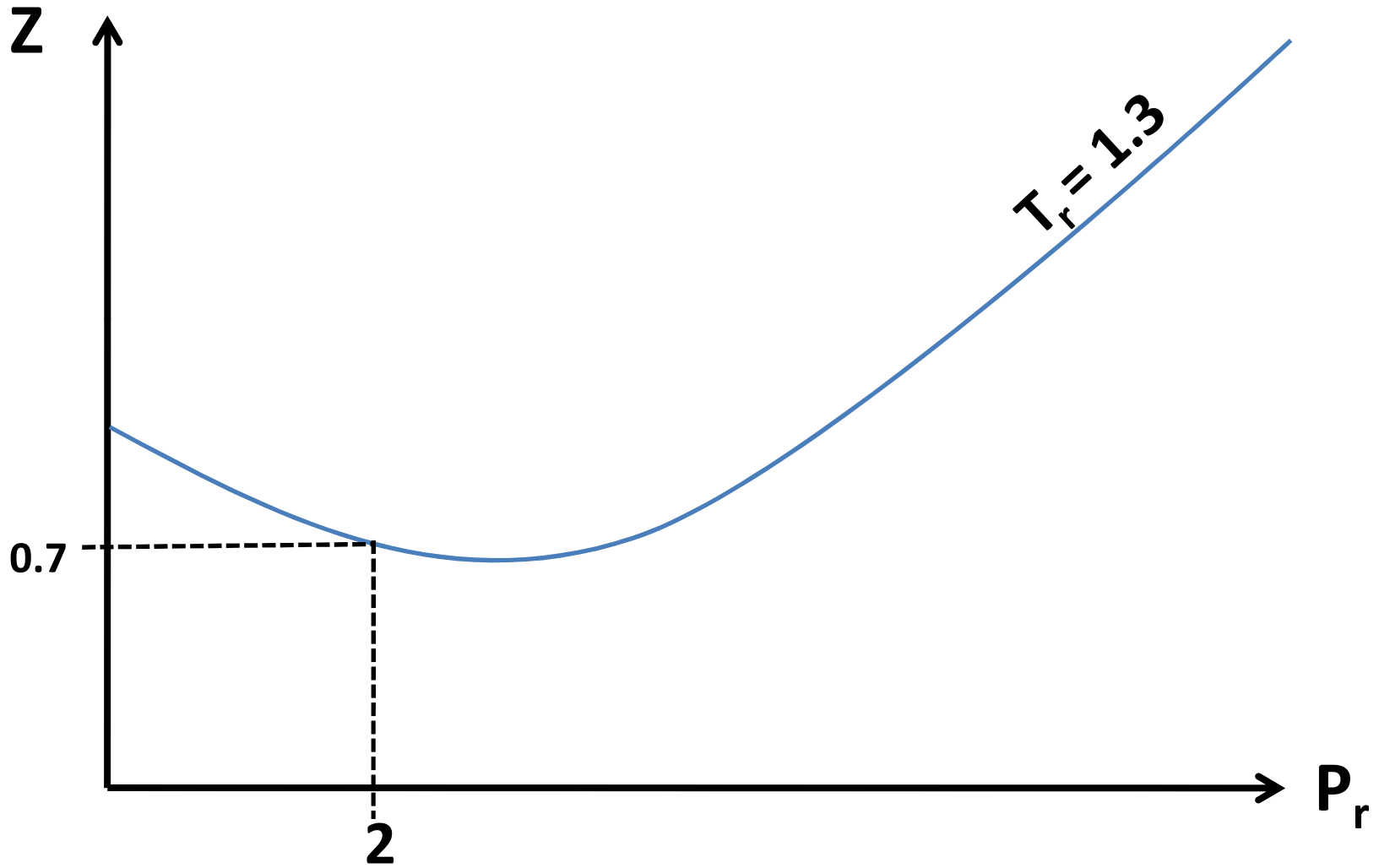



**RSET**

RAJAGIRI SCHOOL OF  
ENGINEERING & TECHNOLOGY

# **INTERNAL ENERGY AND ENTHALPY OF AN IDEAL GAS**

- Internal energy  $U$  and enthalpy  $H$  of an ideal gas is a function of temperature alone

- $U = f(T)$

given by,  $U = m c_v T$  and  $u = c_v T$

i.e. change in internal energy of an ideal gas,

$$\Delta U = m c_v \Delta T \quad \text{and} \quad \Delta u = c_v \Delta T$$

$$dU = m c_v dT \quad \text{and} \quad du = c_v dT$$

- $H = U + PV = m c_v T + m R T = f(T)$

given by,  $H = m c_p T$  and  $h = c_p T$

i.e. change in enthalpy of an ideal gas,

$$\Delta H = m c_p \Delta T \quad \text{and} \quad \Delta h = c_p \Delta T$$

$$dH = m c_p dT \quad \text{and} \quad dh = c_p dT$$

$$c_p / c_v = \gamma$$

$$c_p - c_v = R$$

$$c_v = R / (\gamma - 1)$$

$$c_p = \gamma R / (\gamma - 1)$$



**WORK DONE**  
**HEAT TRANSFER**  
**AND**  
**CHANGE IN PROPERTIES**  
**DURING A**  
**REVERSIBLE PROCESS**  
**UNDERGONE BY AN**  
**IDEAL GAS**



# A CONSTANT VOLUME PROCESS (ISOCHORIC, $V=C$ , $dV=0$ )

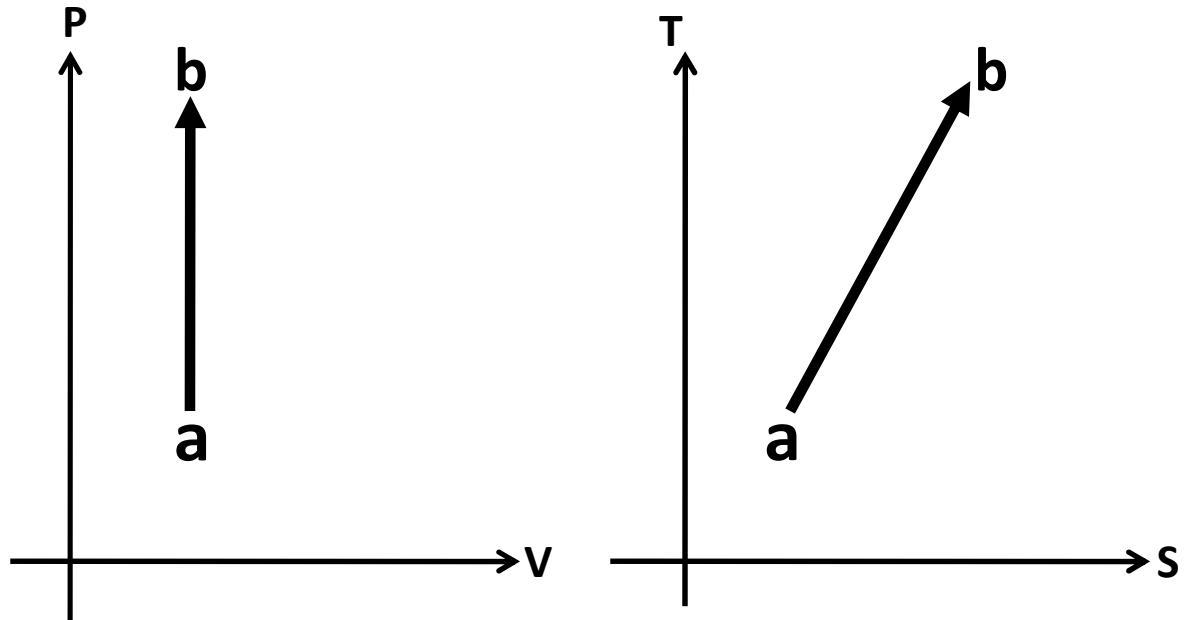
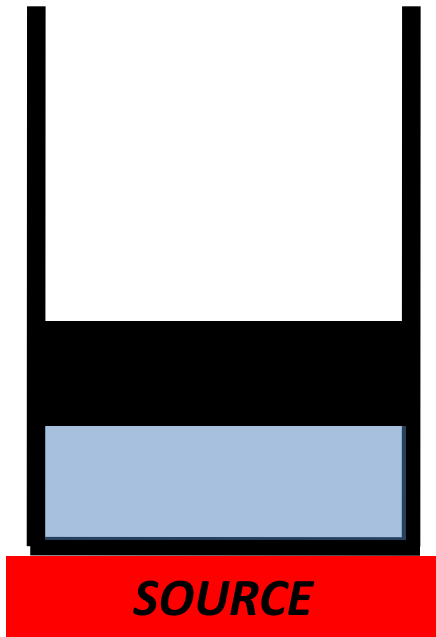

$$P_a V_a / T_a = P_b V_b / T_b$$

$$P_a / P_b = T_a / T_b$$

Applying first law  $\delta Q - \delta W = dU$

Here  $\delta W = P dV = 0$ , so  $\delta Q = dU = m c_v dT$

$$Q_{ab} = m c_v (T_b - T_a)$$

$$T dS = m c_v dT$$

$$dS = m c_v dT / T$$

$$\text{i.e. } \Delta S = S_b - S_a = m c_v \ln (T_b / T_a)$$



**RSET**  
RAJAGIRI SCHOOL OF  
ENGINEERING & TECHNOLOGY

# A CONSTANT PRESSURE PROCESS (ISOBARIC, $P=C$ , $dP=0$ )

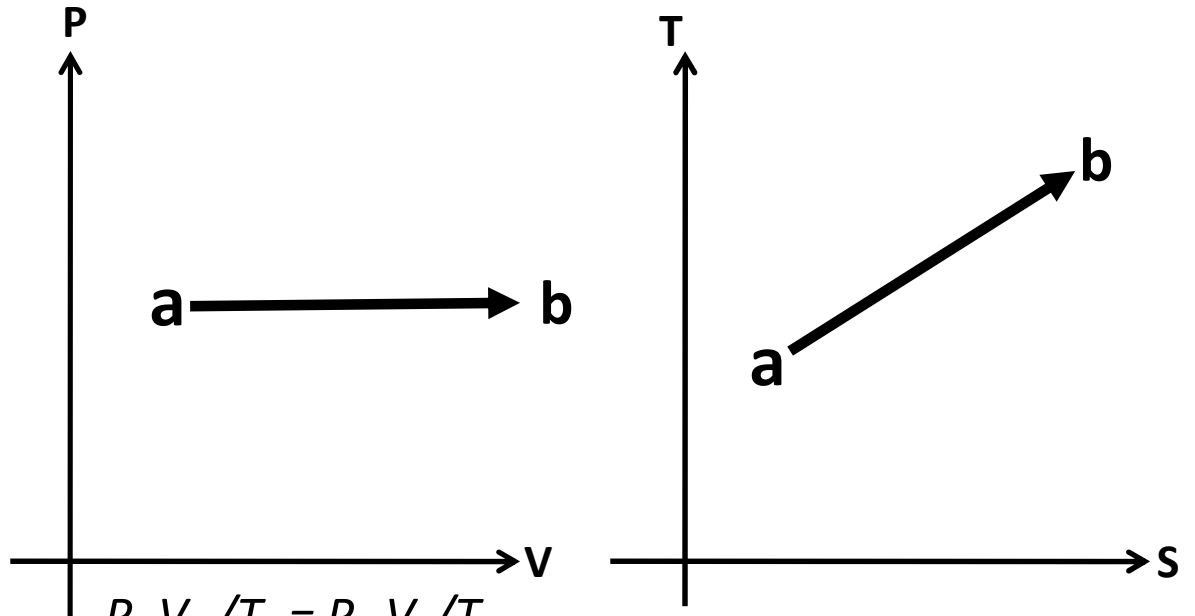
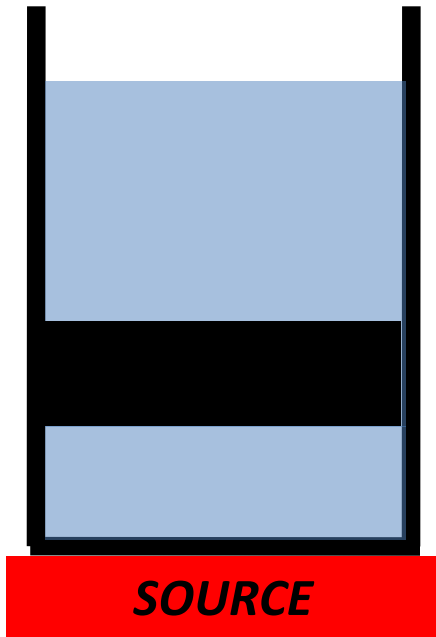

$$P_a V_a / T_a = P_b V_b / T_b$$

$$V_a / V_b = T_a / T_b$$

Applying first law  $\delta Q - \delta W = dU$

$$\delta W = p dV \text{ i.e. } W_{ab} = P(V_b - V_a)$$

$$\delta Q = p dV + dU = dh = m c_p dT \text{ i.e. } Q_{ab} = m c_p (T_b - T_a)$$

$$T ds = m c_p dT$$

$$dS = m c_p dT / T$$

$$\text{i.e. } \Delta S = S_b - S_a = m c_p \ln (T_b / T_a)$$



**RSET**  
RAJAGIRI SCHOOL OF  
ENGINEERING & TECHNOLOGY

# A CONSTANT TEMPERATURE PROCESS

(ISOTHERMAL,  $T=C$ ,  $dT=0$ ,  $dU=0$ )

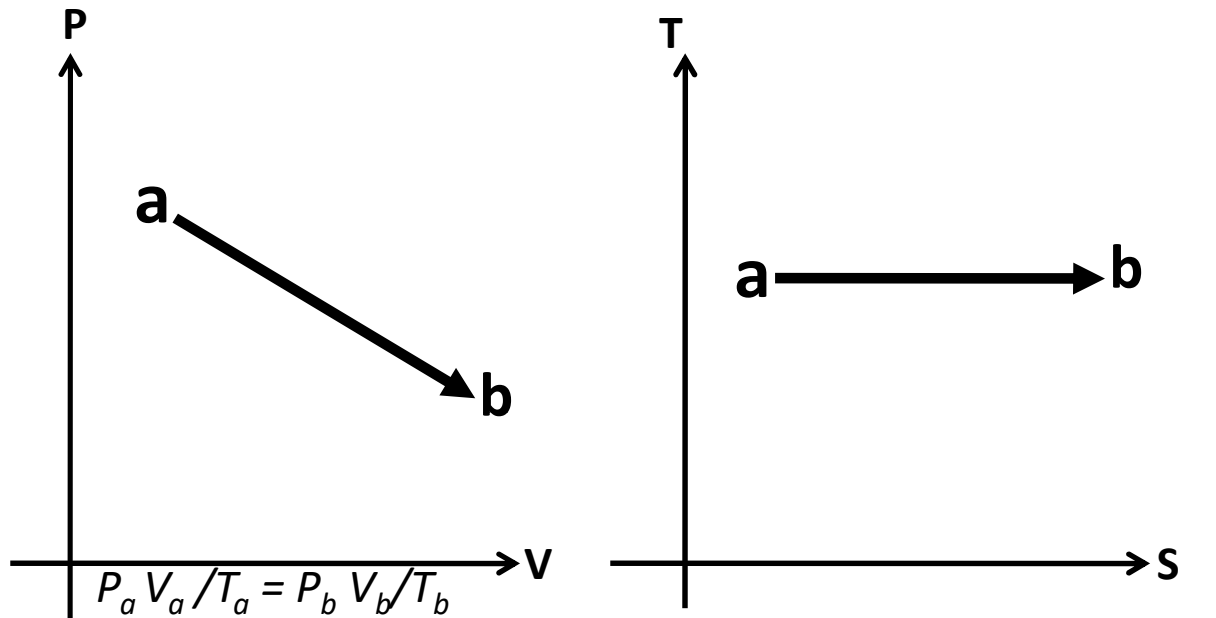
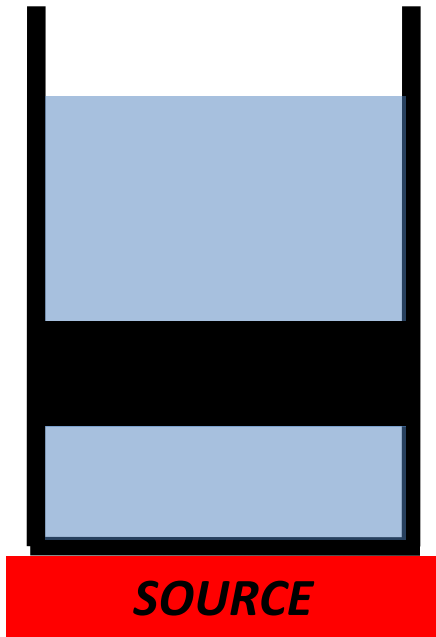

$$P_a V_a / T_a = P_b V_b / T_b$$

$$P_a / P_b = V_b / V_a \quad \text{i.e. } PV = P_a V_a = P_b V_b = C \quad \text{i.e. } P = V/C$$

Applying first law  $\delta Q - \delta W = dU = 0$

$$\delta W = PdV$$

$$\delta Q = PdV \quad \text{i.e. } Q_{ab} = C \int_{ab} dV/V = PV \ln(V_b/V_a) =$$

$$Q_{ab} = mRT \ln(V_b/V_a) = W_{ab}$$

$$TdS = PdV = C dV/V$$

$$dS = C/T dV/V$$

$$\text{i.e. } \Delta S = S_b - S_a = mR \ln(V_b/V_a)$$



**RSET**  
RAJAGIRI SCHOOL OF  
ENGINEERING & TECHNOLOGY

# A CONSTANT ENTROPY PROCESS (ISENTROPIC, $S=C$ , $dS=0$ , $\delta Q=0$ )

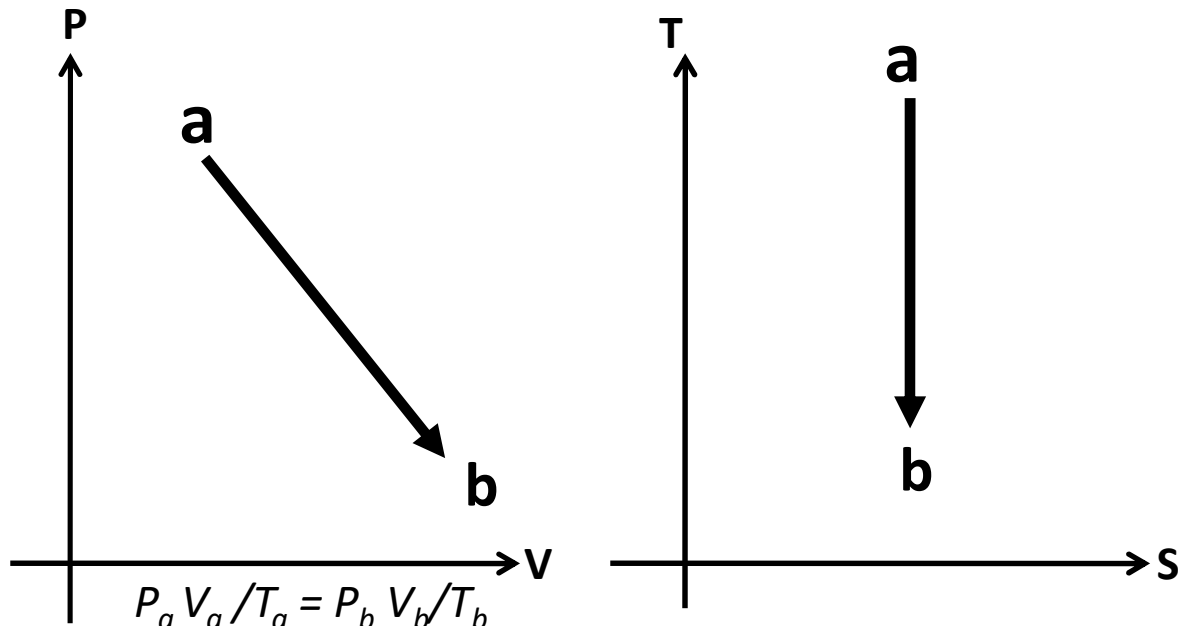
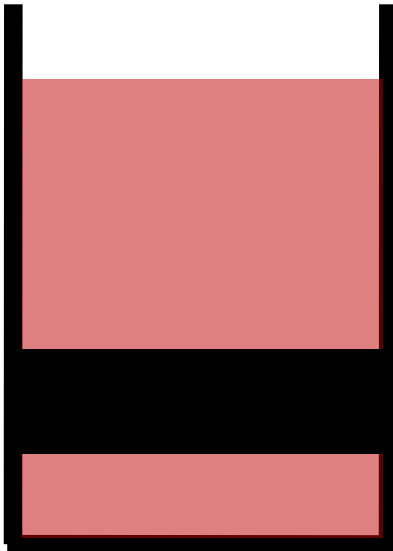

$$P_a V_a / T_a = P_b V_b / T_b$$

$$PV^\gamma = P_a V_a^\gamma = P_b V_b^\gamma = C \quad \text{i.e.} \quad P = V^\gamma / C$$

Applying first law  $\delta Q - \delta W = dU$

$$\delta Q = 0$$

$$\delta W = PdV = dU \quad \text{i.e.} \quad W_{ab} = C \int_{ab} dV/V^\gamma = PV^\gamma (V_b^{-\gamma+1} - V_a^{-\gamma+1})$$

$$W_{ab} = mR (T_b - T_a)$$

$$TdS = 0$$

$$dS = 0$$

$$\text{i.e.} \quad \Delta S = S_b - S_a = 0$$



# IDEAL GAS P-V-T RELATIONSHIPS FOR

## ANY REVERSIBLE PROCESS $a - b$

- Any reversible process can be represented by relation  $PV^n = C$
- $P_a/P_b = (V_b/V_a)^n$
- From ideal gas relation,  $P_a V_a/T_a = P_b V_b/T_b$
- $T_a/T_b = (P_a/P_b) (V_a/V_b)$
- i.e.  $T_a/T_b = (V_b/V_a)^n (V_a/V_b) = (V_b/V_a)^{n-1}$   
 $V_a/V_b = (T_b/T_a)^{1/(n-1)}$
- Also  $T_a/T_b = (P_a/P_b)^{(n-1)/n}$   
 $(P_a/P_b) = (T_a/T_b)^{n/(n-1)}$

$n=0$ , for isobaric process  
 $n=1$ , for isothermal process  
 $n=\gamma$ , for adiabatic(isentropic process)  
 $n=\alpha$ , for isochoric process



# P-V AND T-S DIAGRAM FOR VARIOUS

## RSET REVERSIBLE PROCESSES, $PV^n = C$

RAJAGIRI SCHOOL OF  
ENGINEERING & TECHNOLOGY

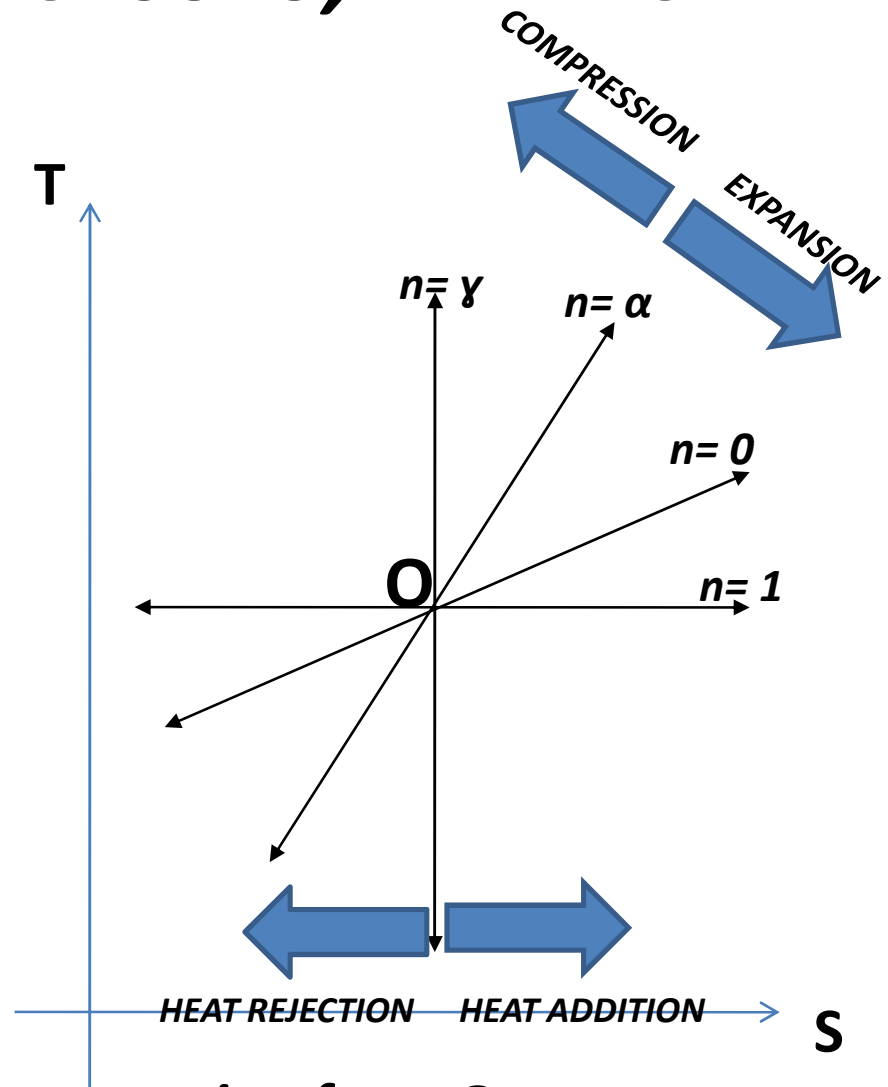
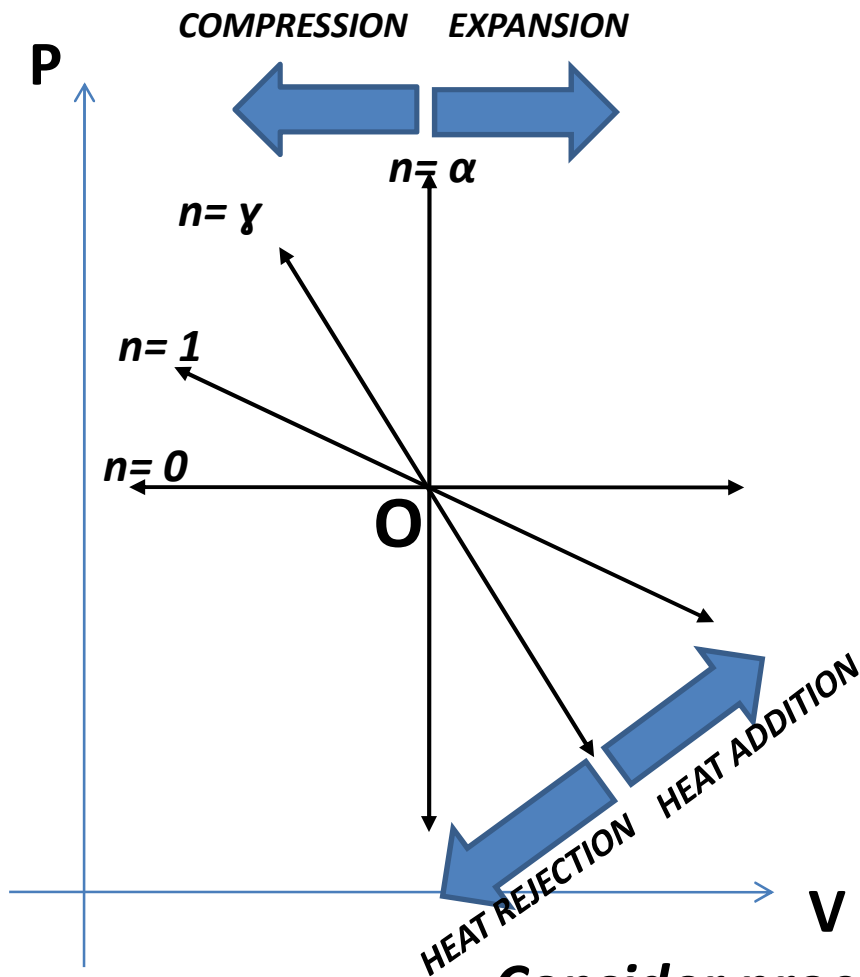

*Consider processes starting from O*



RSET  
RAJAGIRI SCHOOL  
ENGINEERING & TECHNOLOGY

# POLYTROPIC PROCESS $PV^n=C$ (generalized Process)

**Polytropic index,  $n=(\log P_a - \log P_b)/(\log V_b - \log V_a)$**

- $PV^n = C$   $P_a V_a^n = P_b V_b^n$
- $P=C/V^n$

- $W_{ab} = \int_{ab} PdV = \int_{ab} C dV/V^n = C \int_{ab} dV/V^n = P V^n (V_b^{-n+1} - V_a^{-n+1}) / (1-n)$

i.e.  $W_{ab} = m R (T_b - T_a) / (1-n)$  **n not=1**

- Applying first law  $Q_{ab} - W_{ab} = \Delta U_{ab} = m c_v (T_b - T_a)$
- $Q_{ab} = W_{ab} + \Delta U_{ab} = m R (T_b - T_a) / (1-n) + m c_v (T_b - T_a)$

- For an ideal gas  $c_v = R/(\gamma-1)$

- i.e.  $Q_{ab} = m R (T_b - T_a) / (1-n) + m R (T_b - T_a) / (\gamma-1)$
- $= m R (T_b - T_a) [1/(1-n) + 1/(\gamma-1)]$

i.e.  $Q_{ab} = m R (\gamma-n) (T_b - T_a) / (1-n) (\gamma-1)$  **n not=1**

**$\delta Q - \delta W = dU$**

- **$\delta Q = \delta W + dU = PdV + m c_v dT$**

- i.e.  $TdS = PdV + m c_v dT$  i.e.  $dS = PdV/T + m c_v dT/T = m R dV/V + m c_v dT/T$

- $\Delta S = S_b - S_a = m R \ln(V_b/V_a) + m c_v \ln(T_b/T_a)$

- $c_v = R/\gamma-1$  also  $V_b/V_a = (T_b/T_a)^{1/(1-n)}$

- So  $\Delta S = S_b - S_a = m R \ln(T_b/T_a) / (1-n) + m R \ln(T_b/T_a) / (\gamma-1) =$

- $m R \ln(T_b/T_a) [1/(1-n) + 1/(\gamma-1)]$

- i.e.  **$S_b - S_a = m R (\gamma-n) \ln(T_b/T_a) / (1-n) (\gamma-1)$**  **n not=1**



## Practice problem 18(p337)

- *A certain gas has  $c_p = 1.968$  and  $c_v = 1.507$  kJ/kg K. find its molecular weight and characteristic gas constant.*
- *A constant volume chamber of  $0.3 \text{ m}^3$  capacity contains 2 kg of this gas at  $5^\circ\text{C}$ . Heat is transferred to the gas until temperature is  $100^\circ\text{C}$ . Find the work done, the heat transferred, and the change in internal energy enthalpy and entropy.*

**$R = 0.461$  kJ/kg K,  $M = 18.04$  kg/kg mol,  $W = 0$ ,  $Q = 286.33$  kJ,  $\Delta U = 286.33$  kJ  
 $\Delta H = 373$  kJ,  $\Delta S = 0.921$  kJ/K**

## Practice problem 19(p338)

- Show that for an ideal gas, the slope of the constant volume line on the T-S diagram is more than that of the constant pressure line.

*Hint:  $Tds = du + PdV = c_v dT + PdV$*

*i.e.  $(dT/dS)_v = T/c_v$*

*$(dT/dS)_p = T/c_p$*

*since  $c_v < c_p$*

*$(dT/dS)_v > (dT/dS)_p$*

## Practice problem 20(P339)

- 0.5 kg of air is compressed reversibly and adiabatically from 80kPa, 60°C to 0.4 Mpa, and is then expanded at constant pressure to the original volume. Sketch these processes on the P-V and T-S diagram. Compute the heat transfer and work transfer for the whole path.

$$W_{total} = 93.6 \text{ kJ}, \quad Q_{total} = 527.85 \text{ kJ}$$

## Practice problem 21(p342)

- A mass of 0.25 kg of an ideal gas has a pressure of 300kPa, a temperature of of 80°C, and a volume of 0.07 m<sup>3</sup>. the gas undergoes an irreversible adiabatic process to a final pressure of 300 kPa and a final volume of 0.10 m<sup>3</sup>, during which the work done on the gas is 25 kJ. Evaluate the  $c_p$  and  $c_v$  of the gas and increase in entropy of the gas.*

$$c_v = 0.658 \text{ kJ/kg K} \quad c_p = 0.896 \text{ kJ/kgK}$$

$$\Delta S = 0.08 \text{ kJ/kgK}$$



**RSET**  
RAJAGIRI SCHOOL OF  
ENGINEERING & TECHNOLOGY

# ANALYSIS OF CARNOT CYCLE AND EFFICIENCY

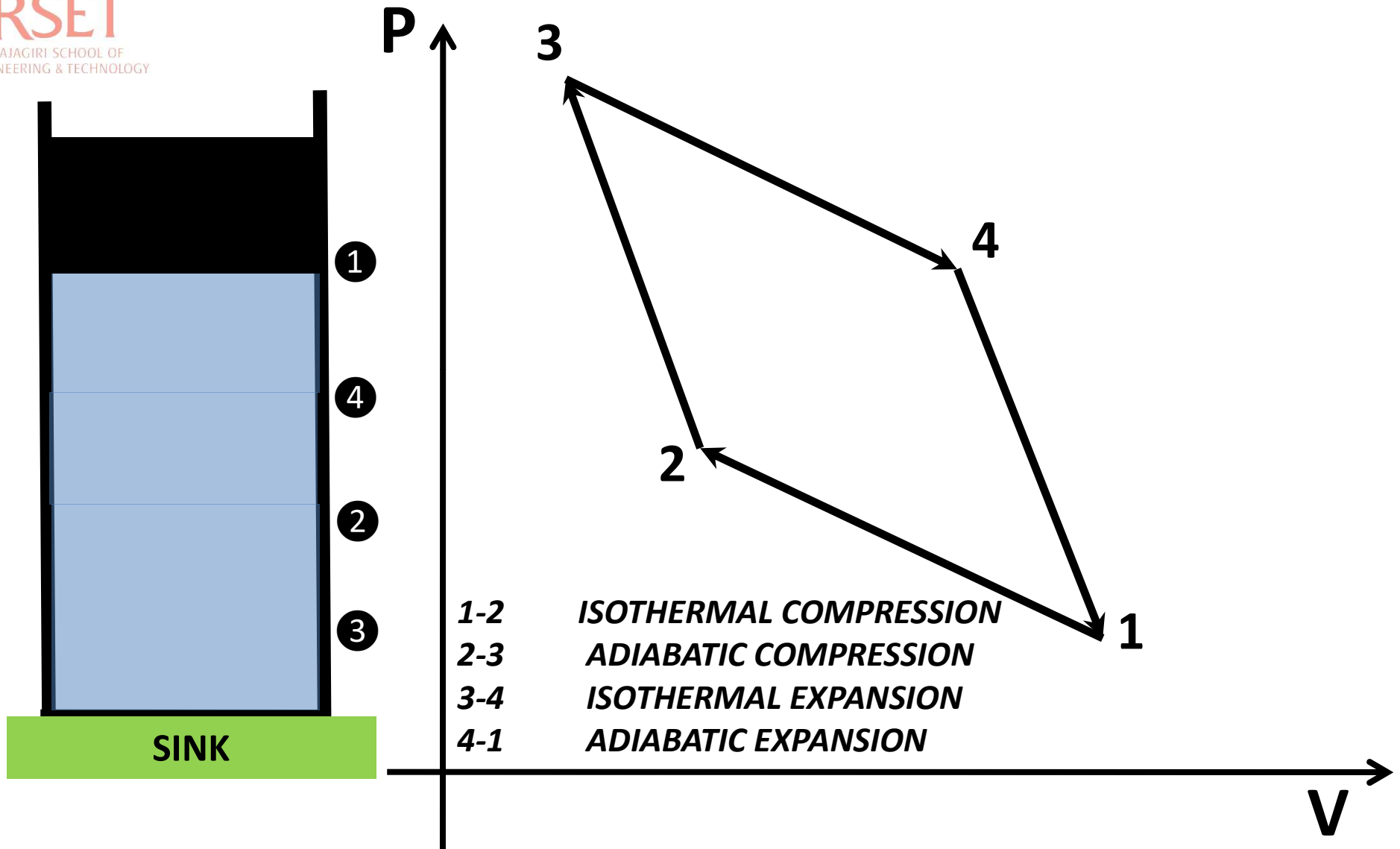



# EFFICIENCY OF A CARNOT CYCLE

RSET

RAJAGIRI INSTITUTE OF  
ENGINEERING & TECHNOLOGY

$$\begin{aligned} \bullet \eta &= W_{net} / Q_i = (Q_i + Q_o) / Q_i = 1 + Q_o / Q_i \\ &= 1 + [m R T_1 \ln(V_2/V_1)] / [m R T_3 \ln(V_4/V_3)] \\ &= 1 - [T_1 \ln(V_1/V_2)] / [T_3 \ln(V_4/V_3)] \end{aligned}$$

- In process 1-2  $T_1 = T_2$
- In process 2-3  $T_2/T_3 = (V_3/V_2)^{(\gamma-1)}$
- In process 3-4  $T_3 = T_4$
- In process 4-1  $T_1/T_4 = (V_4/V_1)^{(\gamma-1)}$
- i.e.  $V_3/V_2 = V_4/V_1$       i.e.  $V_1/V_2 = V_4/V_3$
- i.e.  $\eta = 1 - T_1/T_3 = 1 - T_2/T_4$



RSET

RAJAGIRI SCHOOL OF  
ENGINEERING AND TECHNOLOGY

# Practice Problem 22(p132)

- Which is the more effective way to increase the efficiency of a Carnot engine: to increase  $T_1$  keeping  $T_2$  constant ; or to decrease  $T_2$ , keeping  $T_1$  constant ?

- **HINT** : efficiency is given by  $\eta = 1 - T_2/T_1$

Differentiating  $\eta$  keeping  $T_1$  constant,

$$[d\eta/dT_2]_{T_1} = -1/T_1$$

i.e. as  $T_2$  is decreased efficiency increases(-ve sign)

Differentiating  $\eta$  keeping  $T_2$  constant,

$$[d\eta/dT_1]_{T_2} = T_2/T_1^2$$

i.e. as  $T_1$  is increased efficiency increases

Since  $T_1 > T_2$  ,  $1/T_1 > T_2/T_1^2$

i.e.  $[d\eta/dT_2]_{T_1} > [d\eta/dT_1]_{T_2}$

so more effective way for increasing efficiency of Carnot cycle is decrease  $T_2$ , keeping  $T_1$  constant.



**RSET**  
RAJAGIRI SCHOOL OF  
ENGINEERING & TECHNOLOGY

# ANALYSIS OF OTTO CYCLE AND EFFICIENCY

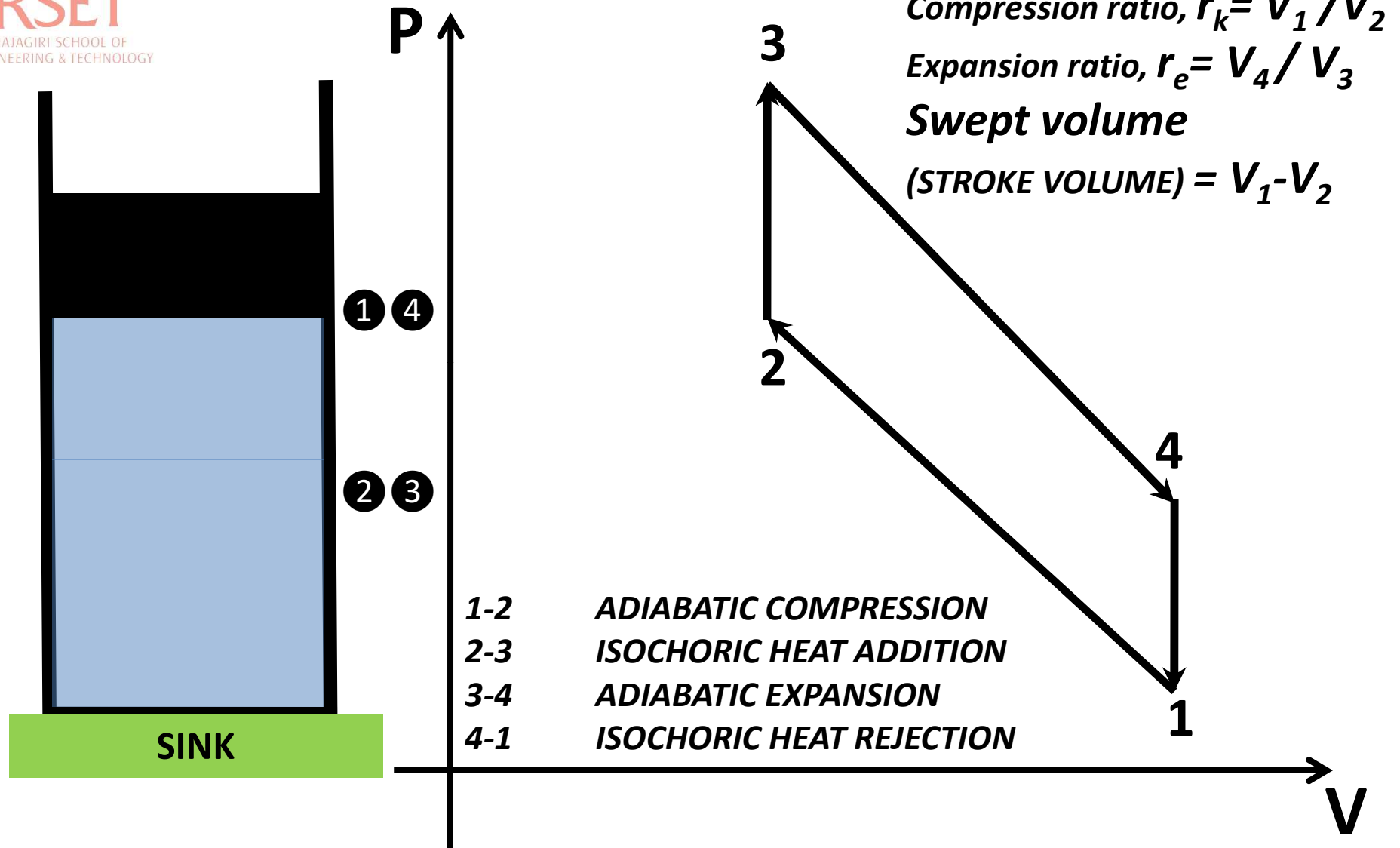





RSET

RAJAGIRI SCHOOL OF  
ENGINEERING & TECHNOLOGY

# EFFICIENCY OF AN OTTO CYCLE

- $\eta = W_{net}/Q_i = (Q_i + Q_o)/Q_i = 1 + Q_o/Q_i$

$$= 1 + [ m c_v (T_1 - T_4) / m c_v (T_3 - T_2) ]$$

$$= 1 + (T_1 - T_4) / (T_3 - T_2) = 1 - (T_4 - T_1) / (T_3 - T_2)$$

- Let us try to rewrite this equation in terms of compression OR expansion ratio

$$\eta = 1 - (T_4/T_3) (1 - T_1/T_4) / (1 - T_2/T_3)$$

- In process 1-2  $T_1/T_2 = (V_2/V_1)^{(\gamma-1)}$

- In process 3-4  $T_3/T_4 = (V_4/V_3)^{(\gamma-1)} = (V_1/V_2)^{(\gamma-1)}$

- i.e.  $T_1/T_2 = T_4/T_3$  i.e.  $T_1/T_4 = T_2/T_3$

- $\eta = 1 - T_4/T_3 = 1 - (V_3/V_4)^{(1-\gamma)}$

- $\eta = 1 - 1/r_k^{(\gamma-1)}$

**Mean effective pressure ,  
 $P_m = W_{net} / \text{swept volume}$**

## Practice problem 23(p523)

- An engine working on the Otto cycle is supplied with air at 0.1 MPa, 35°C. The compression ratio is 8. Heat supplied is 2100 kJ/kg. calculate the maximum pressure and temperature of the cycle, the cycle efficiency, and the mean effective pressure ( for air  $c_p = 1.005$  kJ/kg K,  $c_v = 0.718$  kJ/kg K ) ? Also draw T-S diagram for the cycle.*

$$P_{max} = 9.426 \text{ Mpa} \quad T_{max} = 3633 \text{ K} \quad \eta = 56.5 \%$$
$$P_m = 1.533 \text{ MPa}$$



**RSET**  
RAJAGIRI SCHOOL OF  
ENGINEERING & TECHNOLOGY

# ANALYSIS OF DIESEL CYCLE AND EFFICIENCY

Compression ratio  $r_k = V_1/V_2$

Cut-off ratio  $r_c = V_3/V_2$

Expansion ratio  $r_e = V_4/V_3$

$r_k = r_e r_c$

Swept volume

(STROKE VOLUME) =  $V_1 - V_2$

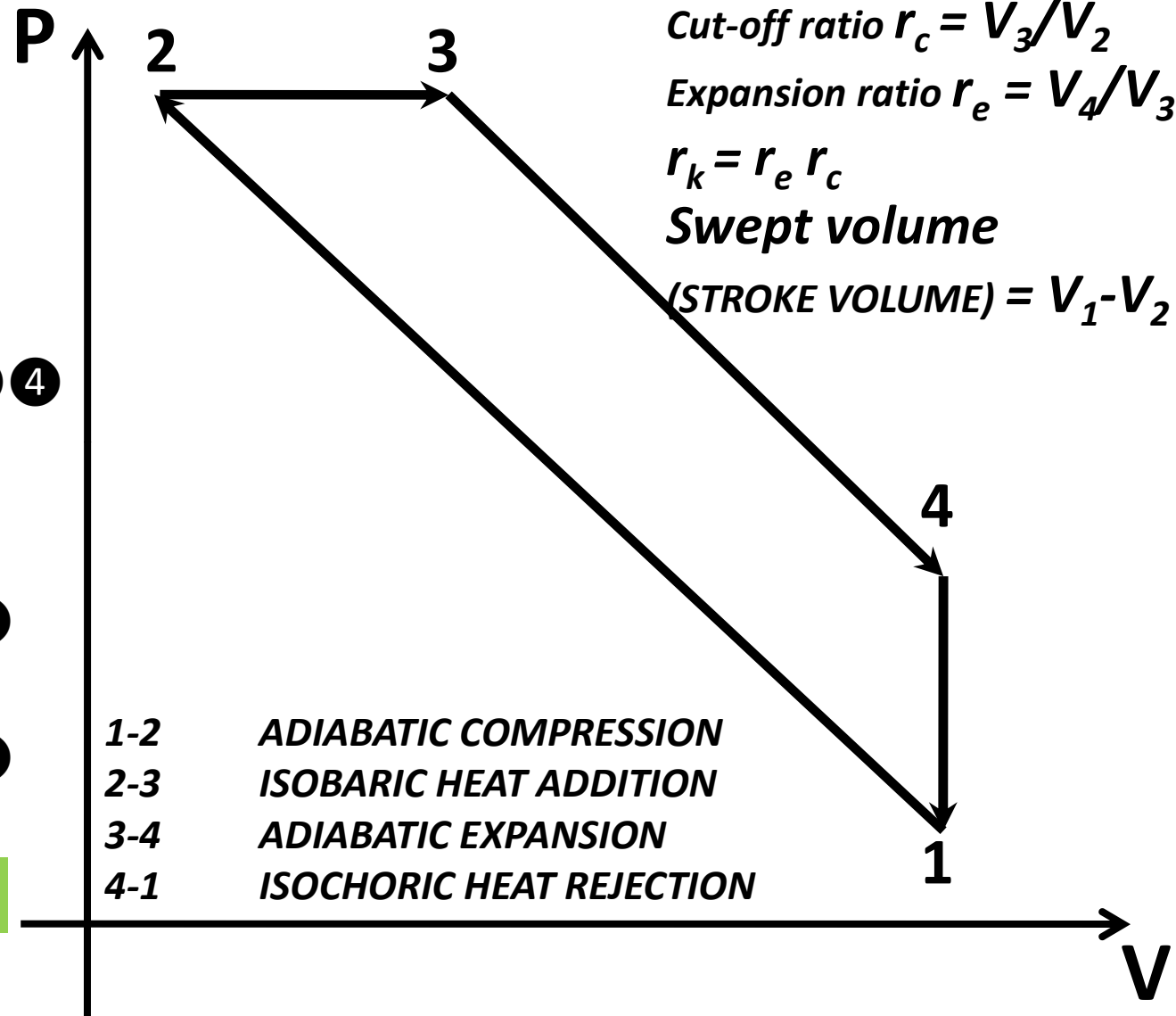
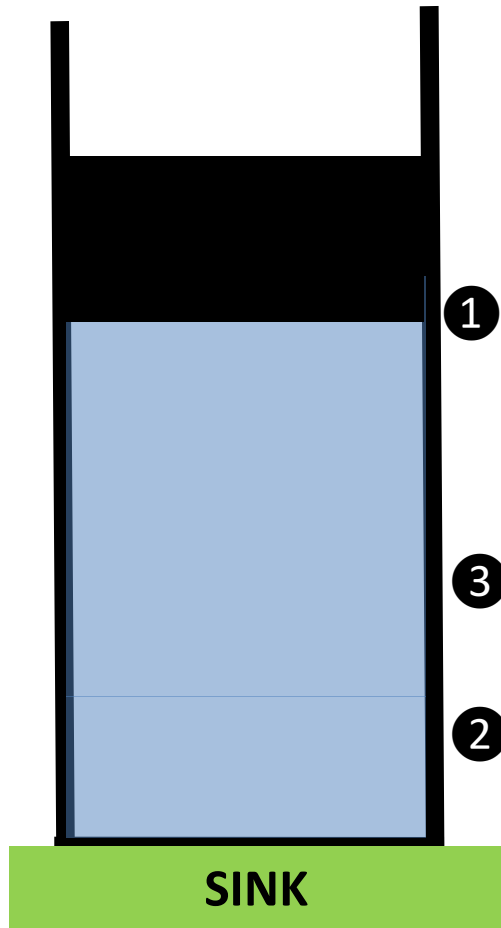



# EFFICIENCY OF A DIESEL CYCLE

- $\eta = W_{net}/Q_i = (Q_i + Q_o)/Q_i = 1 + Q_o/Q_i$   
 $= 1 + [m c_v (T_1 - T_4) / m c_p (T_3 - T_2)] \quad c_p/c_v = \gamma$   
 $= 1 + (1/\gamma) (T_1 - T_4)/(T_3 - T_2) = 1 - (1/\gamma) (T_4 - T_1)/(T_3 - T_2)$
- Let us try to rewrite this equation in terms of compression, expansion and cutoff ratios.
- In process 3-4  $T_4/T_3 = (V_3/V_4)^{(\gamma-1)} = 1/r_e^{(\gamma-1)}$   
 i.e.  $T_4 = T_3/r_e^{(\gamma-1)} = T_3 r_c^{(\gamma-1)} / r_k^{(\gamma-1)}$
- In process 2-3  $T_2/T_3 = (V_2/V_3) = 1/r_c$   
 i.e.  $T_2 = T_3/r_c$
- in process 1-2  $T_1/T_2 = (V_2/V_1)^{(\gamma-1)} = 1/r_k^{(\gamma-1)}$   
 i.e.  $T_1 = T_2/r_k^{(\gamma-1)}$   
 i.e.  $T_1 = T_3/(r_c r_k^{(\gamma-1)})$  -----sub for  $T_2$
- Now we got  $T_1$ ,  $T_2$  and  $T_4$  in terms of  $T_3$ . substituting these values in  $\eta$
- $\eta = 1 - (1/\gamma) [ T_3 r_c^{(\gamma-1)} / r_k^{(\gamma-1)} - T_3 / (r_c r_k^{(\gamma-1)}) ] / [ T_3 - T_3 / r_c ]$
- Cancelling all  $T_3$ ,  $\eta = 1 - (1/\gamma) [ r_c^{(\gamma-1)} / r_k^{(\gamma-1)} - 1 / (r_c r_k^{(\gamma-1)}) ] / [ 1 - 1/r_c ]$
- $\eta = 1 - [ 1 / (\gamma r_k^{(\gamma-1)}) ] [ r_c^\gamma - 1 ] / [ r_c - 1 ]$

## Practice problem 24(p524)

- A Diesel engine has a compression ratio of 14 and cut off takes place at 6% of the *stroke* (*max volume – min volume*) . Find the air standard efficiency. Also draw T-S diagram for the cycle.
- *If an Otto cycle engine(pertol engine) is used with same compression ratio, prove that efficiency of Otto cycle is more. (take  $\gamma = 1.4$ )*

***Diesel = 60.5 %***

***Otto = 65.2 %***

# Practice problem 25(p525)

- In an air standard diesel cycle the compression ratio is 16 and at the beginning of isentropic compression the temperature is 15 °C and pressure is 0.1 MPa. Heat is added until the temperature at the end of the constant pressure process is 1480 °C .
- Calculate cutoff ratio **16**
- Calculate heat supplied per kg of air **884.4 kJ/kg**
- Calculate the cycle efficiency and MEP **61.2 %**  
**698 45 kPa**



**RSET**  
RAJAGIRI SCHOOL OF  
ENGINEERING & TECHNOLOGY

# ANALYSIS OF BRAYTON CYCLE AND EFFICIENCY

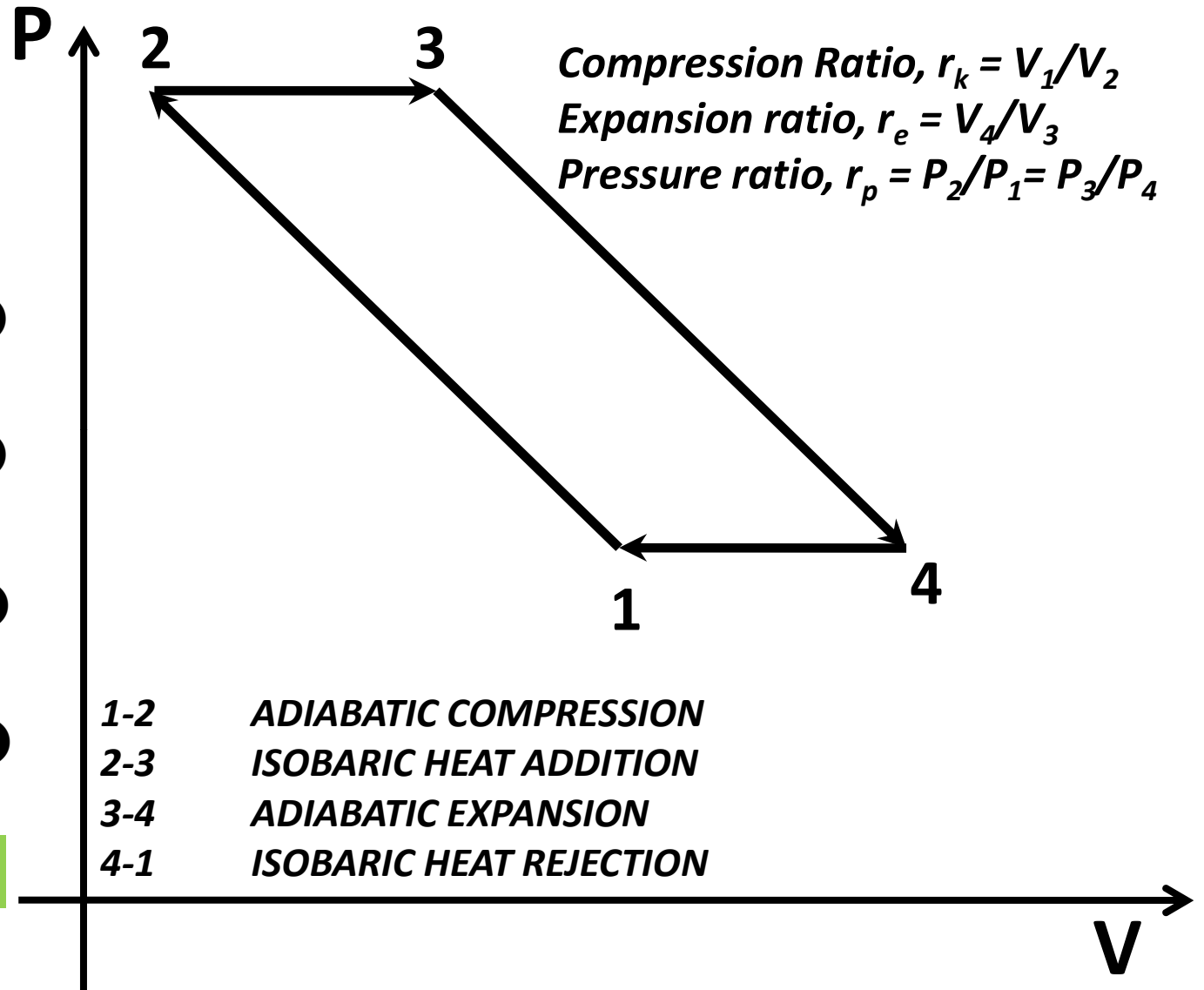
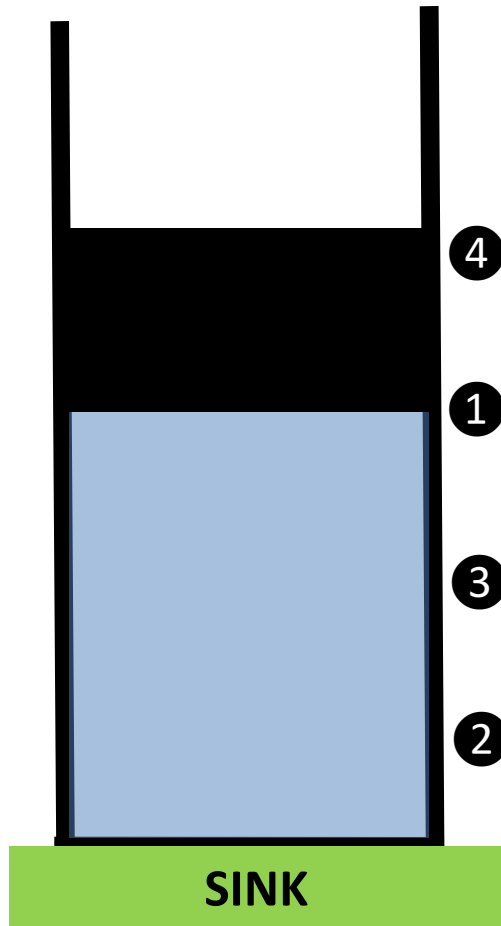



# EFFICIENCY OF A BRAYTON CYCLE

RSET

$$\bullet \eta = W_{net}/Q_i = (Q_i + Q_o)/Q_i = 1 + Q_o/Q_i$$

$$= 1 + [ m c_p (T_1 - T_4) / m c_p (T_3 - T_2) ]$$

$$= 1 + (T_1 - T_4) / (T_3 - T_2) = 1 - (T_4 - T_1) / (T_3 - T_2)$$

- Let us try to rewrite this equation in terms of compression, expansion and pressure ratios

- In process 1-2  $T_2/T_1 = (P_2/P_1)^{(\gamma-1)/\gamma}$

- In process 3-4  $T_3/T_4 = (P_3/P_4)^{(\gamma-1)/\gamma} = (P_2/P_1)^{(\gamma-1)/\gamma}$

- i.e.  $T_1/T_2 = T_4/T_3$       i.e.  $T_1/T_4 = T_2/T_3$

- $\eta = 1 - T_4/T_3 = 1 - (P_4/P_3)^{(\gamma-1)/\gamma} = 1 - 1/r_p^{(\gamma-1)/\gamma} = 1 - (V_3/V_4)^{(1-\gamma)}$

- $\eta = 1 - 1/r_k^{(\gamma-1)}$

- $\eta = 1 - 1/r_p^{(\gamma-1)/\gamma}$





# BRAYTON CYCLE POWER PLANT

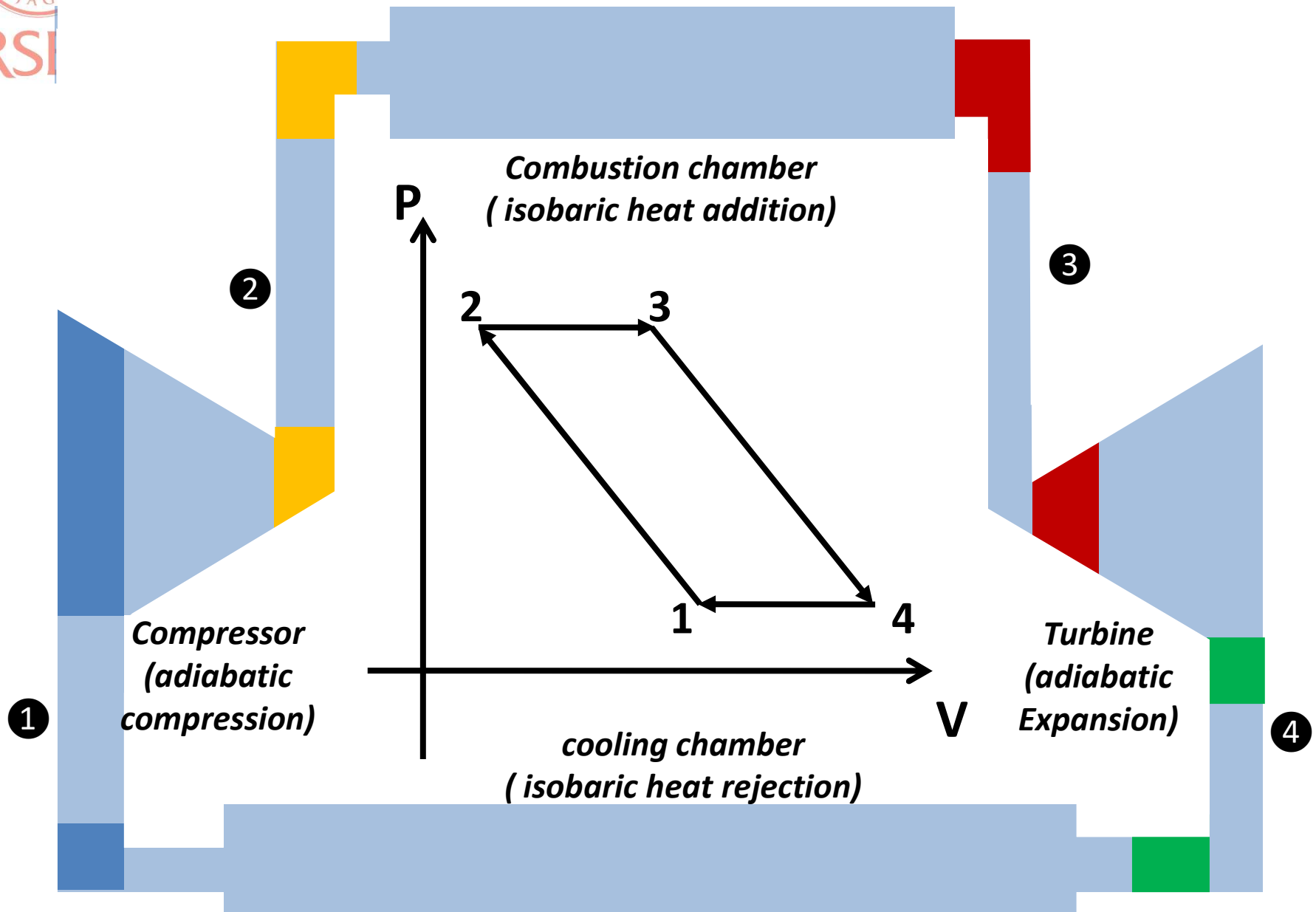

## Practice problem 26(p530)

- *In an ideal Brayton cycle air from the atmosphere at 1 atm, 300K is compressed to 6 atm and maximum cycle temperature is limited to 1100 K by using a large air fuel ratio. If the heat supplied is 100 MW find,*
- *Thermal efficiency of the cycle*      **40.1%**
- *Work ratio=  $(W_{turb} - W_{comp})/W_{turb}$*       **0.545**
- *Power output*      **40.1 MW**
- *Also draw the T-S diagram for the cycle*

# Module II

# **ENERGY CONVERSION DEVICES**

## REFERENCES:

***ENGINEERING THERMODYNAMICS*** by P.K.NAG 3<sup>RD</sup> EDITION

***POWER PLANT ENGINEERING*** by P.K.NAG 3<sup>RD</sup> EDITION



**RSET**

RAJAGIRI SCHOOL OF  
ENGINEERING & TECHNOLOGY

# ***BOILERS***

*Boiler is an apparatus to produce steam*

*Thermal energy released by combustion of fuel is used to make steam at desired temperature and pressure.*

*The steam produced is used for,*

- 1. Producing mechanical work by expanding it in a steam engine or steam turbine.*
- 2. Heating the residential and industrial buildings.*
- 3. Performing certain processes in the sugar mills, chemical and textile industries.*

# ***PROPERTIES OF A GOOD BOILER***

- 1. Safety*** – boiler should be safe under operating conditions
- 2. Accessibility*** - the various parts of the boiler should be accessible for the repair and maintenance.
- 3. Capacity***- should be capable of supplying steam according to the requirement.
- 4. Efficiency***- should be able to absorb a maximum amount of heat produced due to burning of fuel in the furnace
- 5. Construction simplicity.***
- 6. Low initial and maintenance cost.***
- 7. Boiler should have no joints exposed to flames.***
- 8. Should be capable of quick starting and loading.***



# CLASSIFICATION OF BOILERS

**RSET**  
RAJAGIRI SCHOOL OF  
ENGINEERING & TECHNOLOGY

- **WATER TUBE BOILERS-** if water is inside the tube and hot gases are outside the tube.

e.g. *Babcock and Wilcox*

- **FIRE TUBE BOILERS-** if hot gases are inside the tube and water is outside the tube.

e.g. *Cochran, Lancashire and locomotive boilers*

- **EXTERNALLY FIRED** - if furnace is outside the shell

e.g. *Babcock and Wilcox*

- **INTERNALLY FIRED** - if furnace is located outside the boiler shell

e.g. *Cochran, Lancashire and locomotive boilers*

- **HIGH PRESSURE** – produce steam at and above 80 Bar

e.g. *Babcock and Wilcox*

- **LOW PRESSURE-** produce steam below 80 Bar

e.g. *Cochran, Lancashire and locomotive boilers*



# CLASSIFICATION OF BOILERS

**RSET** RAJAGIRI SCHOOL OF ENGINEERING & TECHNOLOGY  
• **FORCED CIRCULATION BOILERS-** *if circulation of water is done by pumps*

*e.g. Benson boilers*

• **NATURAL CIRCULATION BOILERS-** *if circulation of water is due to density difference by application of heat.*

*e.g. Cochran, Babcock and Wilcox*

• **POTRABLE** – *locomotive type or used for temporary use in sites*

*e.g. Locomotive boilers (steam engine trains)*

• **STATIONARY** – *used in powerplants*

*e.g. Cochran, Babcock and Wilcox*

• **HIGH PRESSURE** – *produce steam at and above 80 Bar*

*e.g. Babcock and Wilcox*

• **LOW PRESSURE-** *produce steam below 80 Bar*

*e.g. Cochran, Lancashire and locomotive boilers*

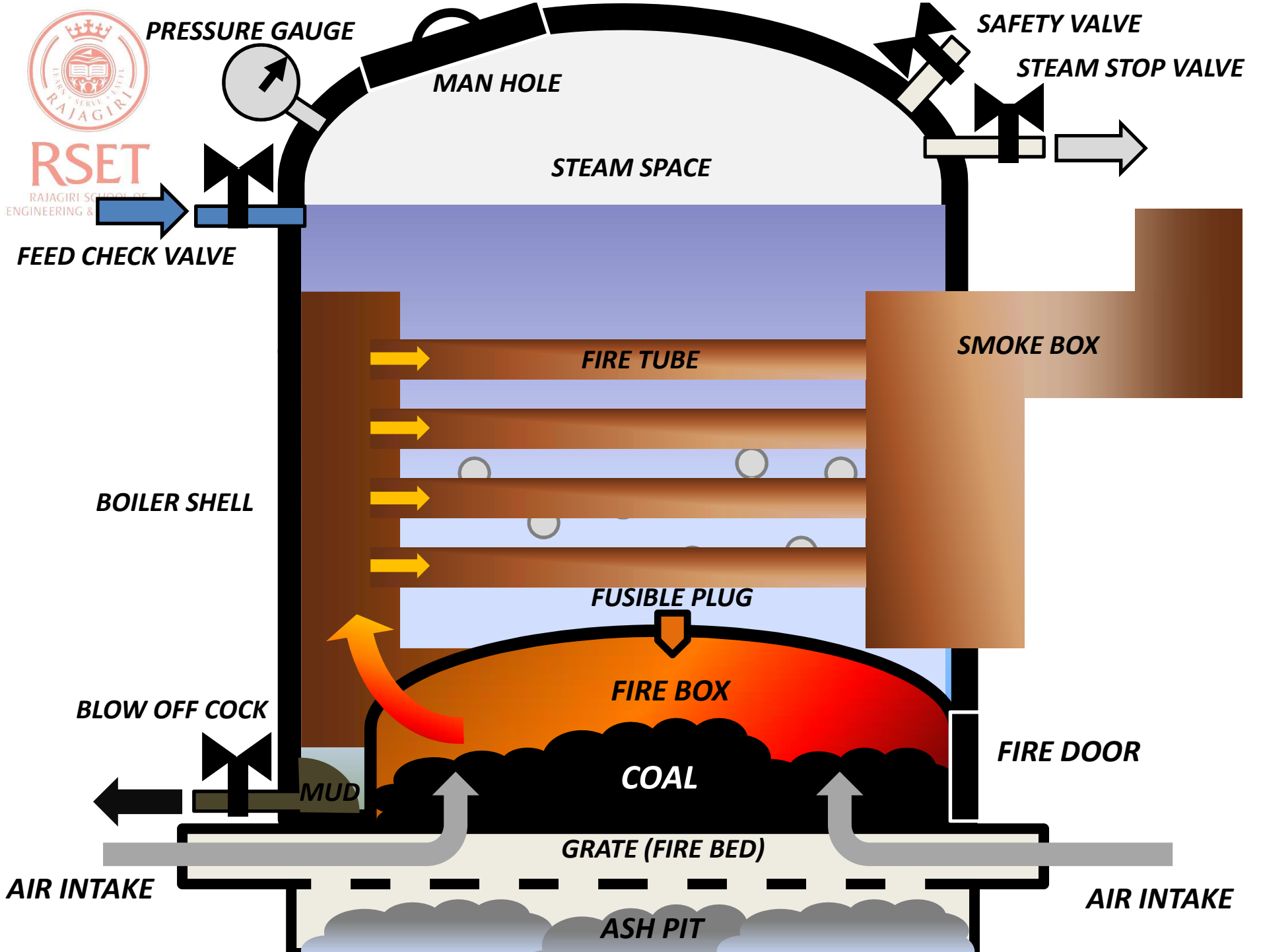



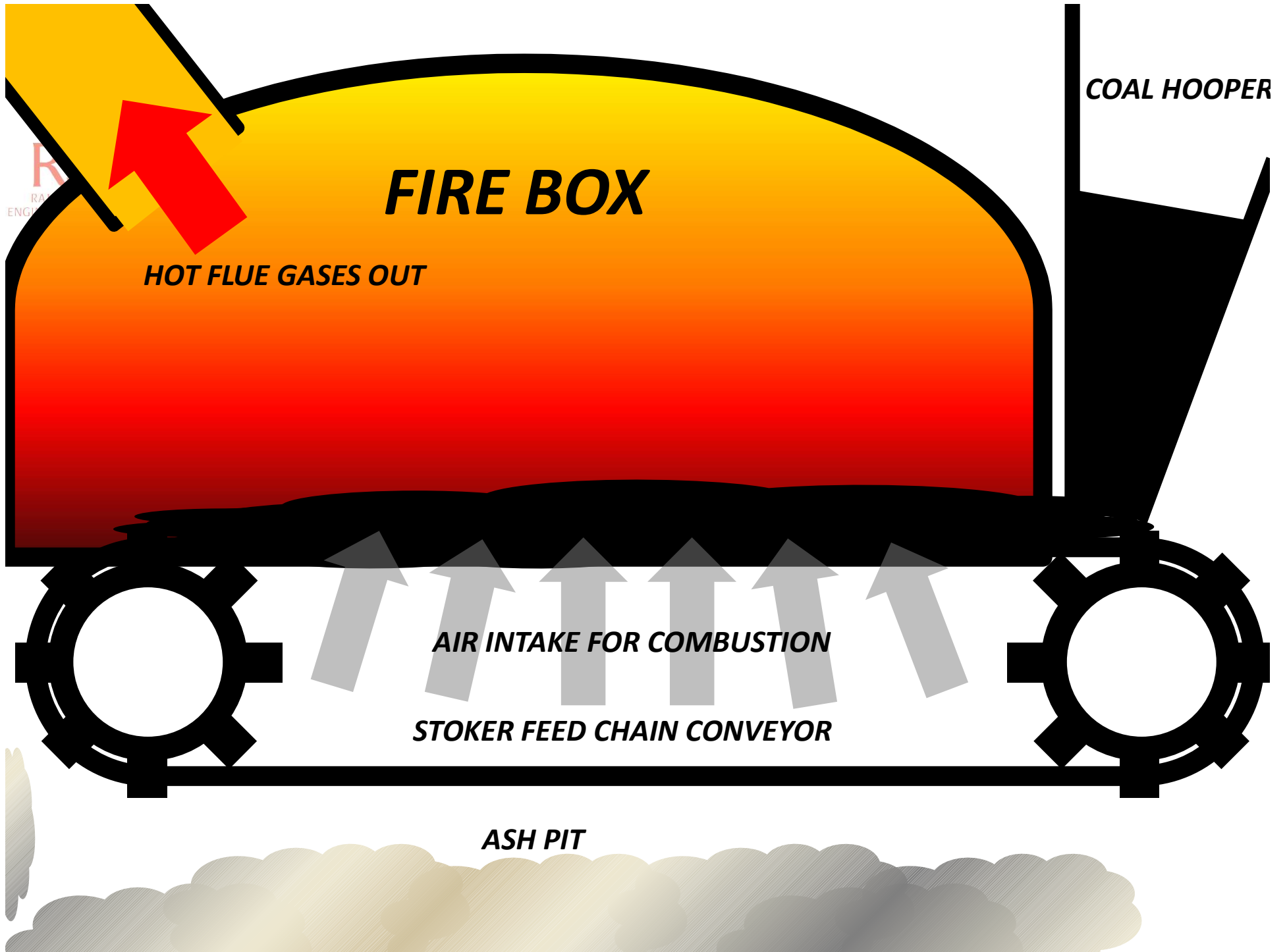

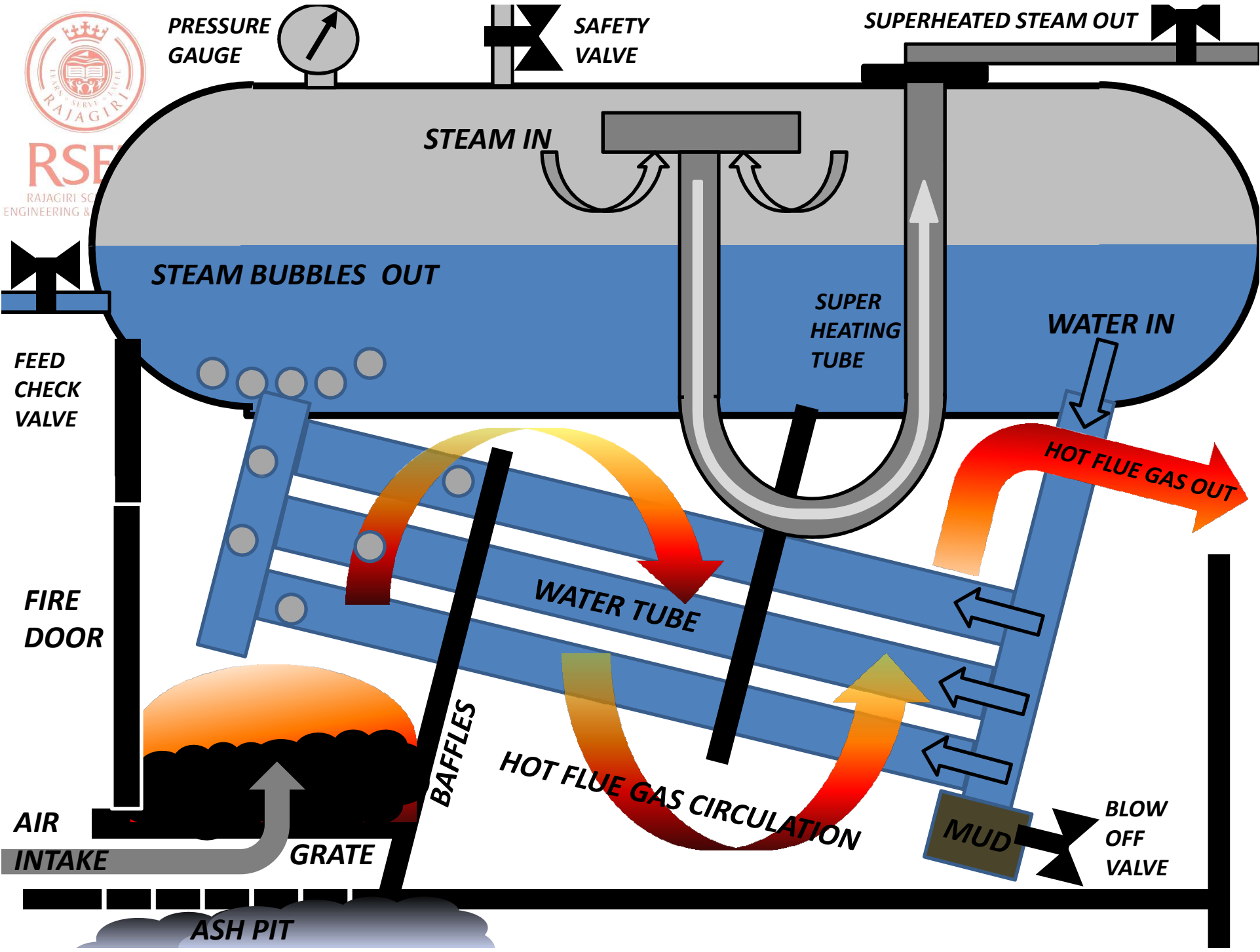

# *DIFFERENCES BETWEEN WATER AND FIRE TUBE BOILERS*

## *FIRE TUBE*

- Construction is difficult*
- Hot gas inside the tube and water outside the tube*
- Internally fired*
- Operating pressure limited to 20 bar*
- Less risk of explosion*
- Not suitable for large power plants*
- Rate of steam production lower*
- For same power it occupies more floor area and big boiler shell*
- Transportation difficult*
- Water treatment not necessary*
- Less accessibility to boiler parts*
- Requires less operating skill*

## *WATER TUBE*

- Construction is simple*
- water inside the tube and hot gas outside the tube*
- Externally fired*
- Operating pressure can go up to 200 bar*
- More risk of explosion*
- Suitable for large power plants*
- Rate of steam production higher*
- For same power it occupies less floor area and small boiler shell.*
- Transportation simple.*
- Water treatment necessary*
- More accessibility to boiler parts*
- Requires more operating skill*

# ***TURBINES***

- *A turbine is a Roto-dynamic device that extracts energy from a flowing fluid and converts it into useful work. the fluid may be compressible (vapor, gas etc) or incompressible (liquids)*



# **TURBINES CLASSIFICATIONS**

**RSET**

RAJAGIRI SCHOOL  
ENGINEERING & TECHNOLOGY

## **BASED ON WORKING FLUID**

### **HOT COMBUSTION GAS-**

*Gas turbine*

- **STEAM –**

*Steam turbine*

- **WATER-**

*Hydraulic turbine*

- **MERCURY-**

*Mercury turbine*

## **BASED ON ACTION OF WORKING FLUID ON TURBINE**

- **IMPULSE TURBINE –** *Torque produced by change in momentum of the flowing fluid*
- **REACTION TURBINE –** *Torque produced by change in momentum as well as change in pressure of flowing fluid*

## **BASED ON THE DISCHARGE QUANTITY OF WORKING FLUID**

- **LOW DISCHARGE-** *Pelton wheel*
- **MEDIUM DISCHARGE –** *Francis turbine*
- **HIGH DISCHARGE-** *Kaplan turbine*



**RSET**

RAJAGIRI SCHOOL OF  
ENGINEERING & TECHNOLOGY

# **TURBINES CLASSIFICATIONS**

## **BASED ON THE NET HEAD AVAILABLE AT TURBINE INLET**

- **HIGH HEAD-** *Pelton wheel*
- **MEDIUM HEAD –** *Francis turbine*
- **LOW HEAD-** *Kaplan turbine*

## **BASED ON THE SPECIFIC SPEED, $N_s$ (SPEED OF A TURBINE FOR UNIT POWER OUTPUT FOR A UNIT HEAD)**

- **10 TO 50 RPM –** *Pelton wheel*
- **50- 250 RPM –** *Francis turbine*
- **250- 850 RPM –** *Kaplan turbine*

## **BASED ON FLOW OF THE WORKING FLUID THROUGH THE TURBINE RUNNERS**

- **TANGENTIAL FLOW-** *fluid hits the turbine tangentially*
- **RADIAL FLOW -** *fluid enters radially and leaves radially(Francis turbine)*
- **MIXED FLOW-** *fluid enters radially and leaves axially(Francis turbine)*
- **AXIAL FLOW-** *fluid enters axially and leaves axially(Kaplan turbine)*

# IMPULSE MOMENTUM PRINCIPLE (principle of impulse turbines)

ACCORDING TO NEWTONS SECOND LAW ,  
FORCE IS DIRECTLY PROPORTIONAL TO RATE OF CHANGE OF MOMENTUM

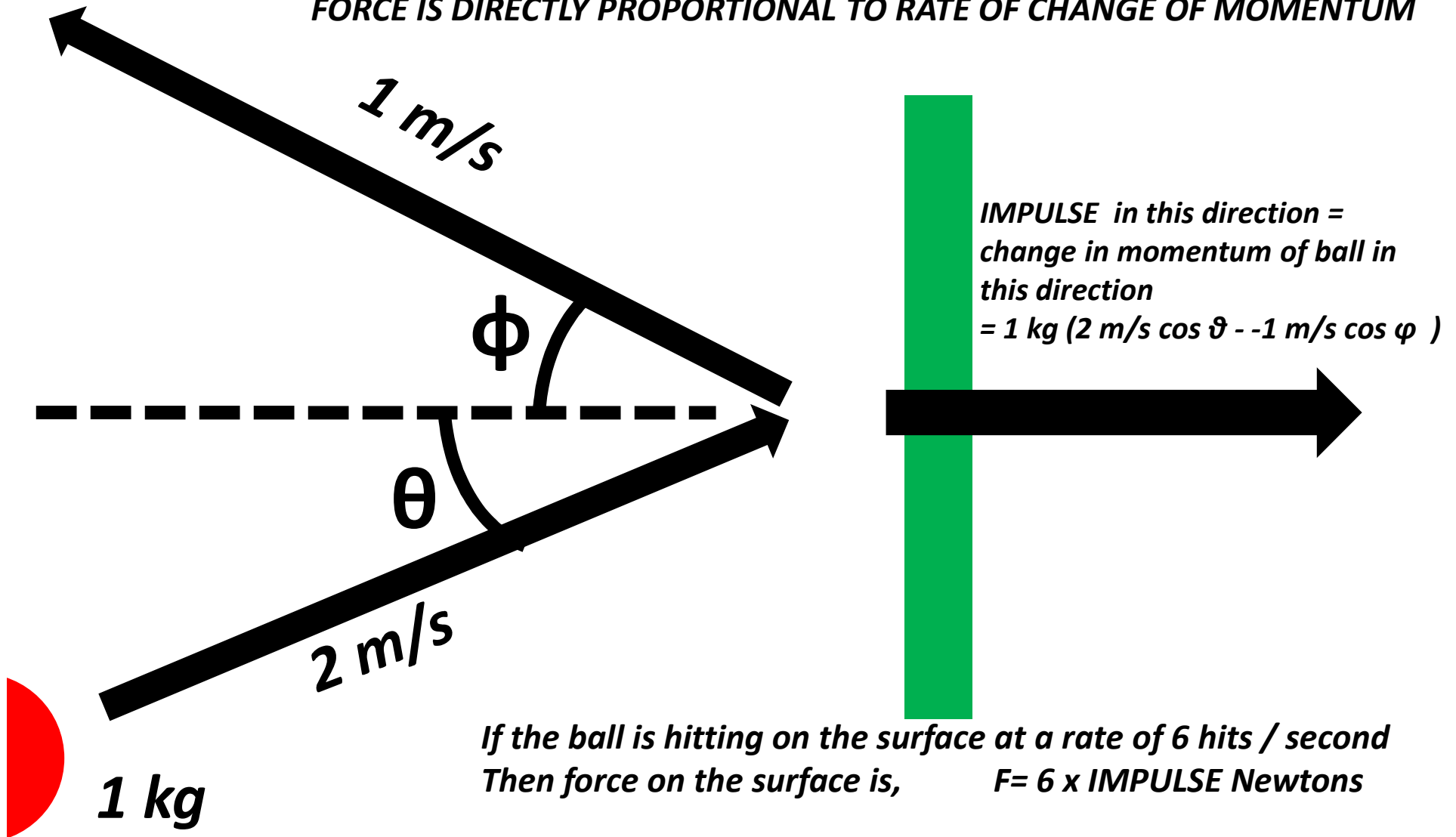

# REACTION PRINCIPLE (principle of reaction turbines)

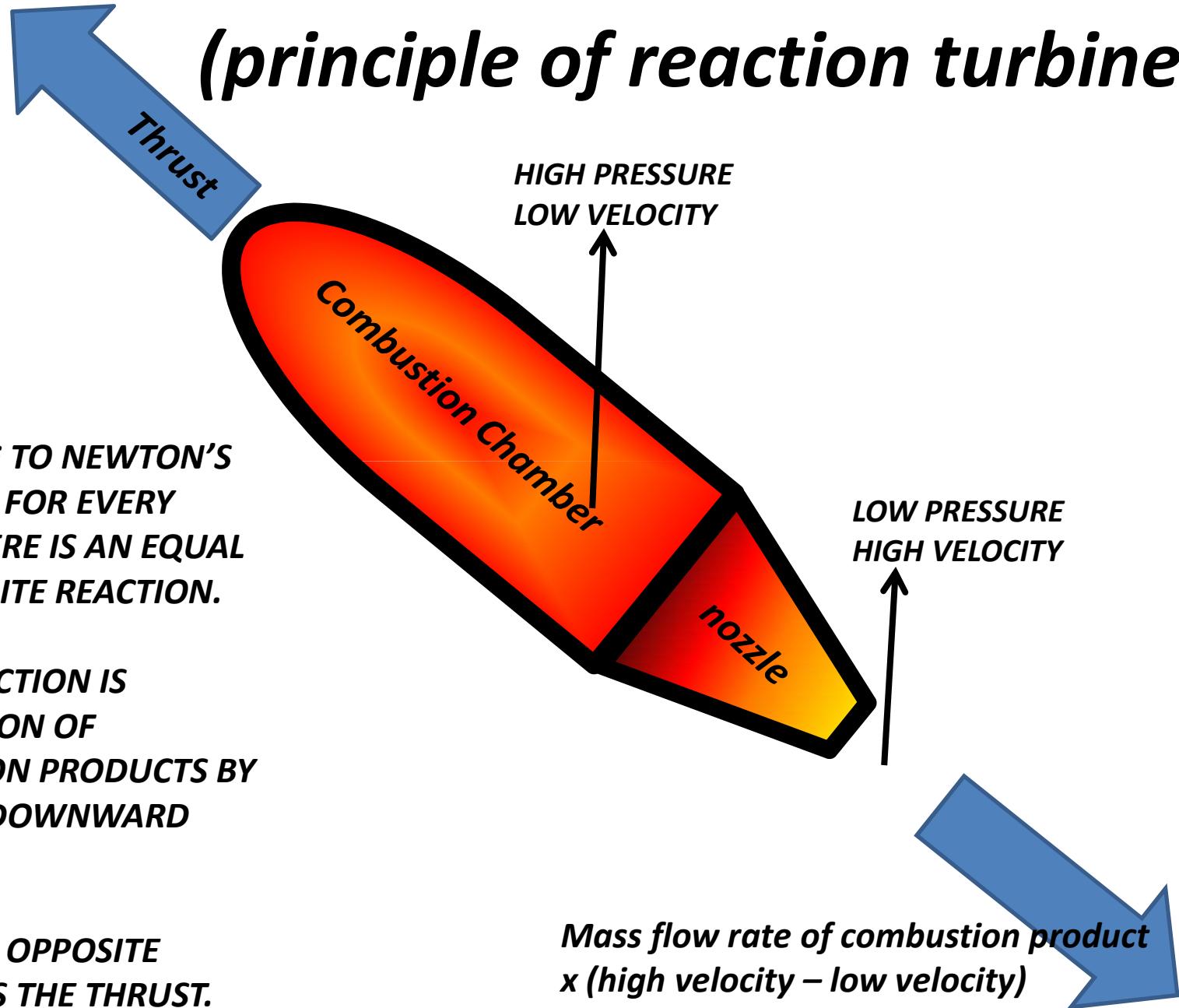

**ACCORDING TO NEWTON'S  
THIRD LAW, FOR EVERY  
ACTION THERE IS AN EQUAL  
AND OPPOSITE REACTION.**

**HERE THE ACTION IS  
ACCELERATION OF  
COMBUSTION PRODUCTS BY  
NOZZLE IN DOWNWARD  
DIRECTION.**

**EQUAL AND OPPOSITE  
REACTION IS THE THRUST.**





**RSET**  
RAJAGIRI SCHOOL OF  
ENGINEERING & TECHNOLOGY

# HYDRAULIC TURBINES

***IMPULSE  
TURBINE***

• *Pelton*

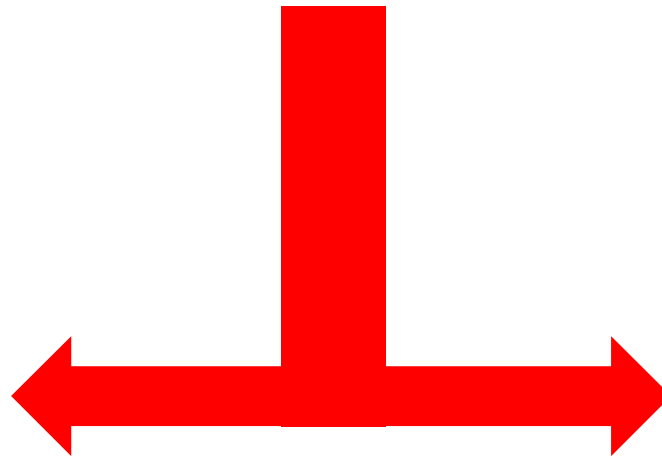

***REACTION  
TURBINE***

• *Francis*  
• *Kaplan*



RSET  
RAJAGIRI SCHOOL  
ENGINEERING & TECHNOLOGY

# HYDRAULIC IMPULSE TURBINES

- **High head turbines-**

*Net Head available at the inlet of the turbine is more than 250 m. These are **low discharge type** turbines (because discharge through the impulse turbine nozzle is less).*

*e.g. Pelton wheel*

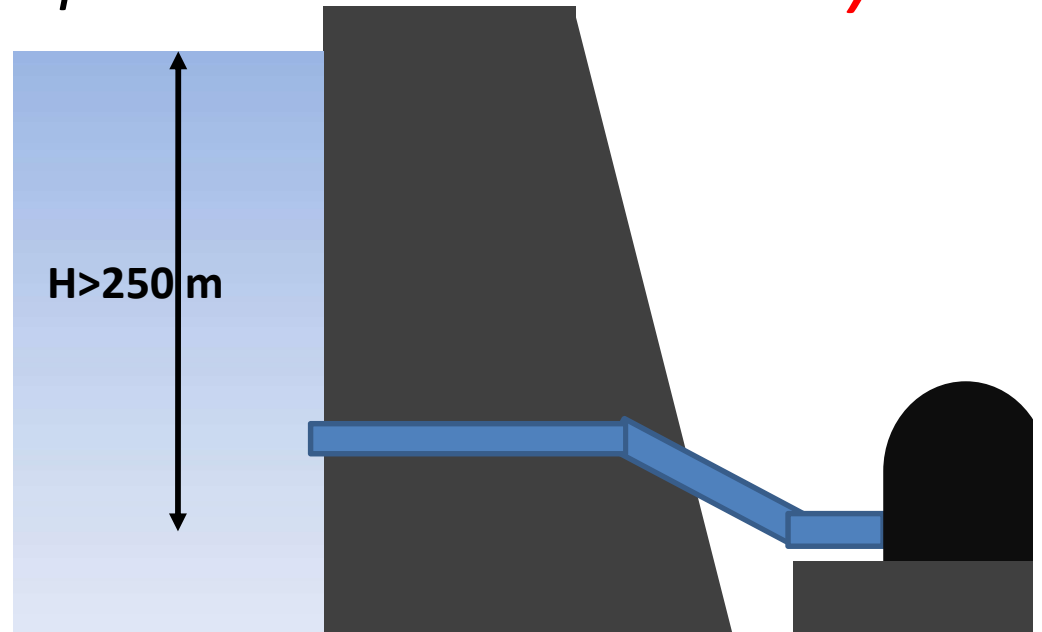



**RSET**  
RAJAGIRI SCHOOL OF  
ENGINEERING & TECHNOLOGY

# ***PELTON WHEEL BUCKET SHAPED VANES***





**RSET**

RAJAGIRI SCHOOL OF  
ENGINEERING & TECHNOLOGY

# ***PELTON WHEEL HOUSING WITH WATER JET NOZZLE***

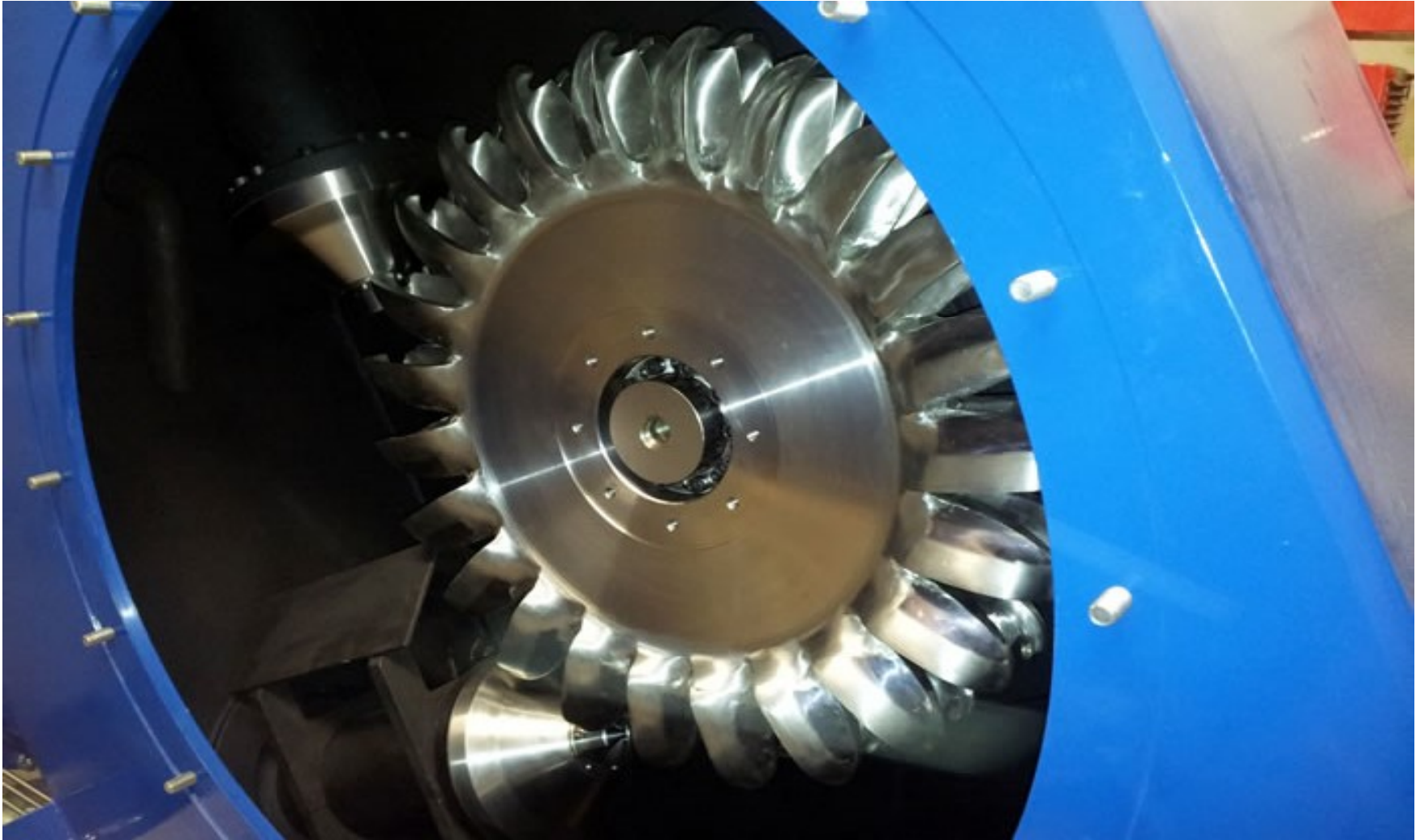



**RSET**  
RAJAGIRI SCHOOL OF  
ENGINEERING & TECHNOLOGY

# ***ACTION OF HIGH VELOCITY WATER JET ON BUCKETS***

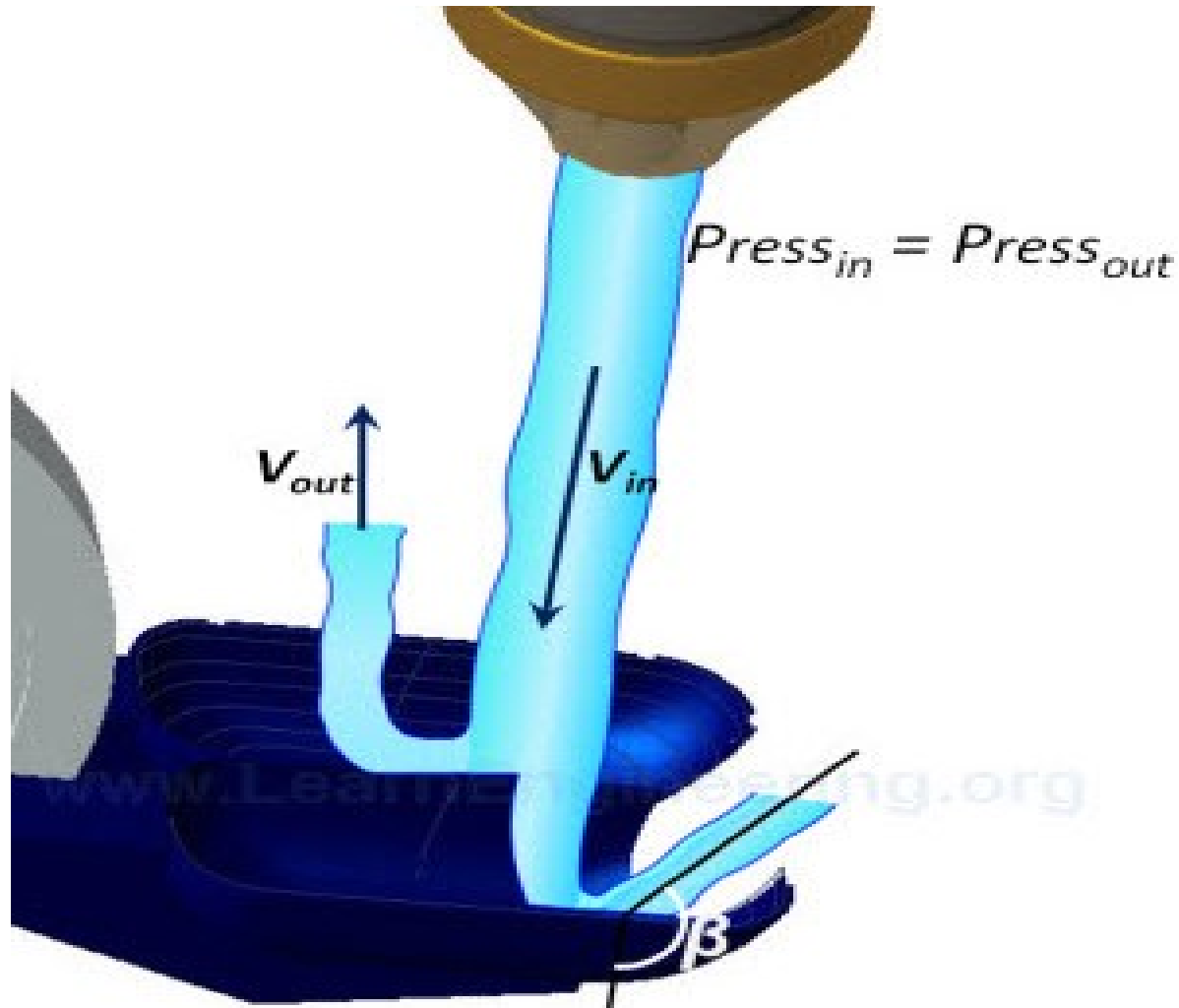



# **BUCKET CROSS SECTION SCHEMATIC**

**RSET**  
RAJAGIRI SCHOOL OF  
ENGINEERING & TECHNOLOGY

**WATER JET CHANGES DIRECTION WHILE HITTING THE BUCKET AND SO THERE IS A CHANGE IN MOMENTUM (DUE TO CHANGE IN DIRECTION OF VELOCITY)**

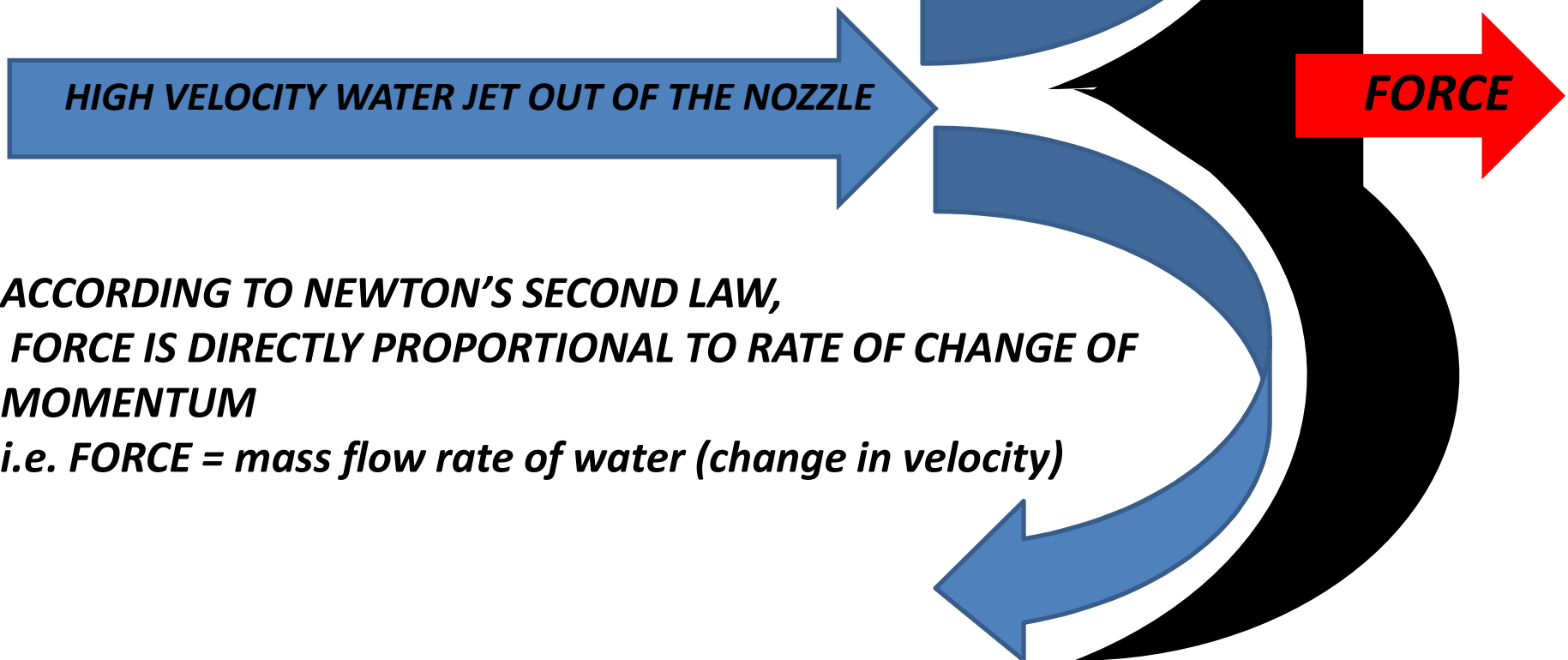

**ACCORDING TO NEWTON'S SECOND LAW,  
FORCE IS DIRECTLY PROPORTIONAL TO RATE OF CHANGE OF  
MOMENTUM**

***i.e. FORCE = mass flow rate of water (change in velocity)***



**RSET**

RAJAGIRI SCHOOL OF  
ENGINEERING & TECHNOLOGY

# HYDRAULIC REACTION TURBINES

- **FRANCIS TURBINE**(medium head)- Net head available at the inlet of the turbine is between 60 and 250 m. These turbines are of medium discharge. Specific speed ranges from 50- 250 rpm.
- **KAPLAN TURBINE**(low head)- Net head available at the inlet of the turbine is below 60 m. This turbine requires high discharge. Specific speed ranges from 250- 850 rpm.

# ***FRANCIS TURBINE RUNNER***







**RSET**

RAJAGIRI SCHOOL OF  
ENGINEERING & TECHNOLOGY

# FRANCIS TURBINE SCHEMATIC FRONT VIEW

**POWER  
OUTPUT  
SHAFT**

**VOLUTE CASING**

**GUIDE VANE**

*height of the turbine above tailrace, is provided for inspection and maintenance, but decreases efficiency*

**DRAFT TUBE**  
*(A tube of increasing cross section area connecting the exit of the turbine runner and tail race, decreases pressure at exit of the turbine runner thereby increasing efficiency)*

**TAIL RACE**

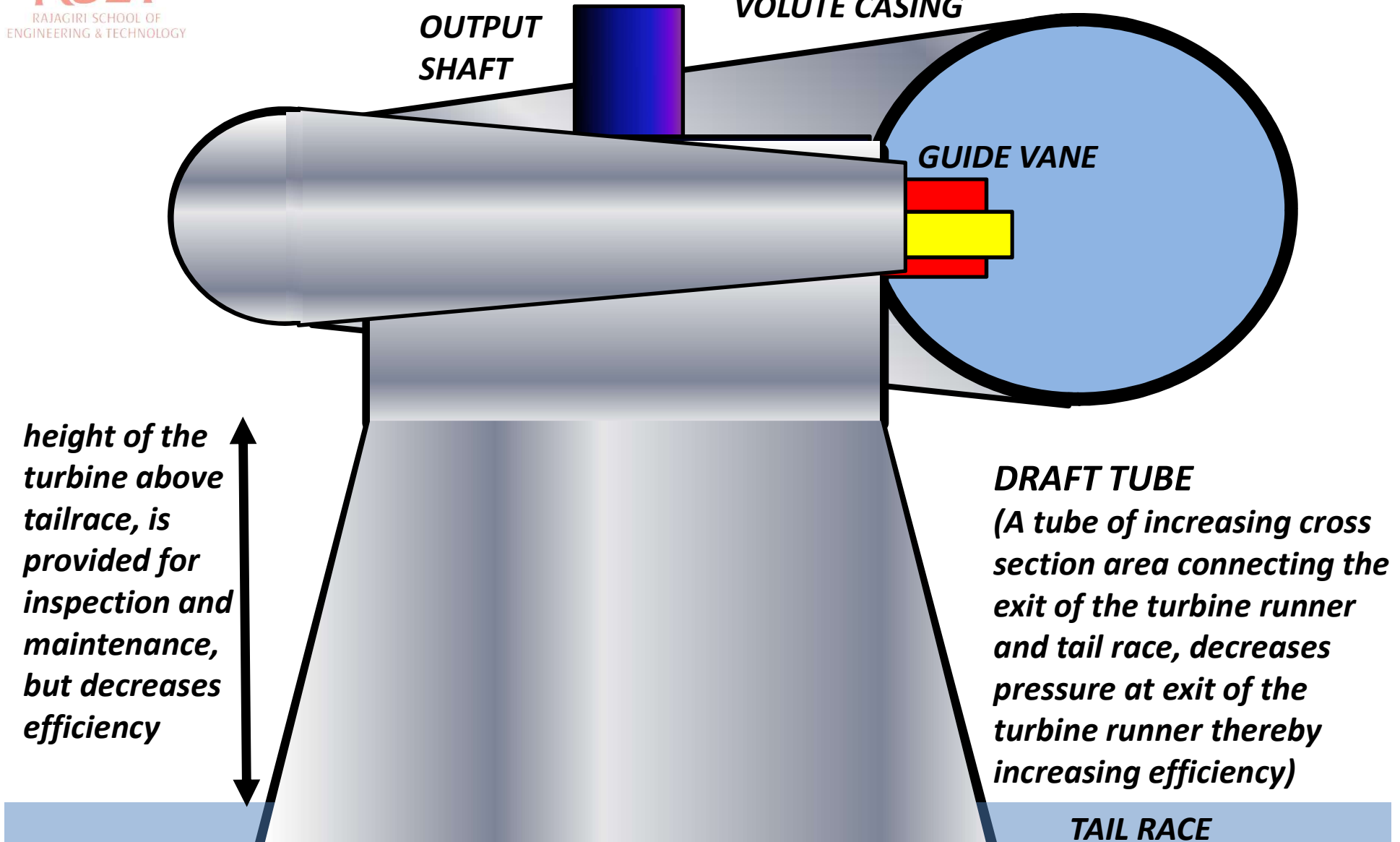

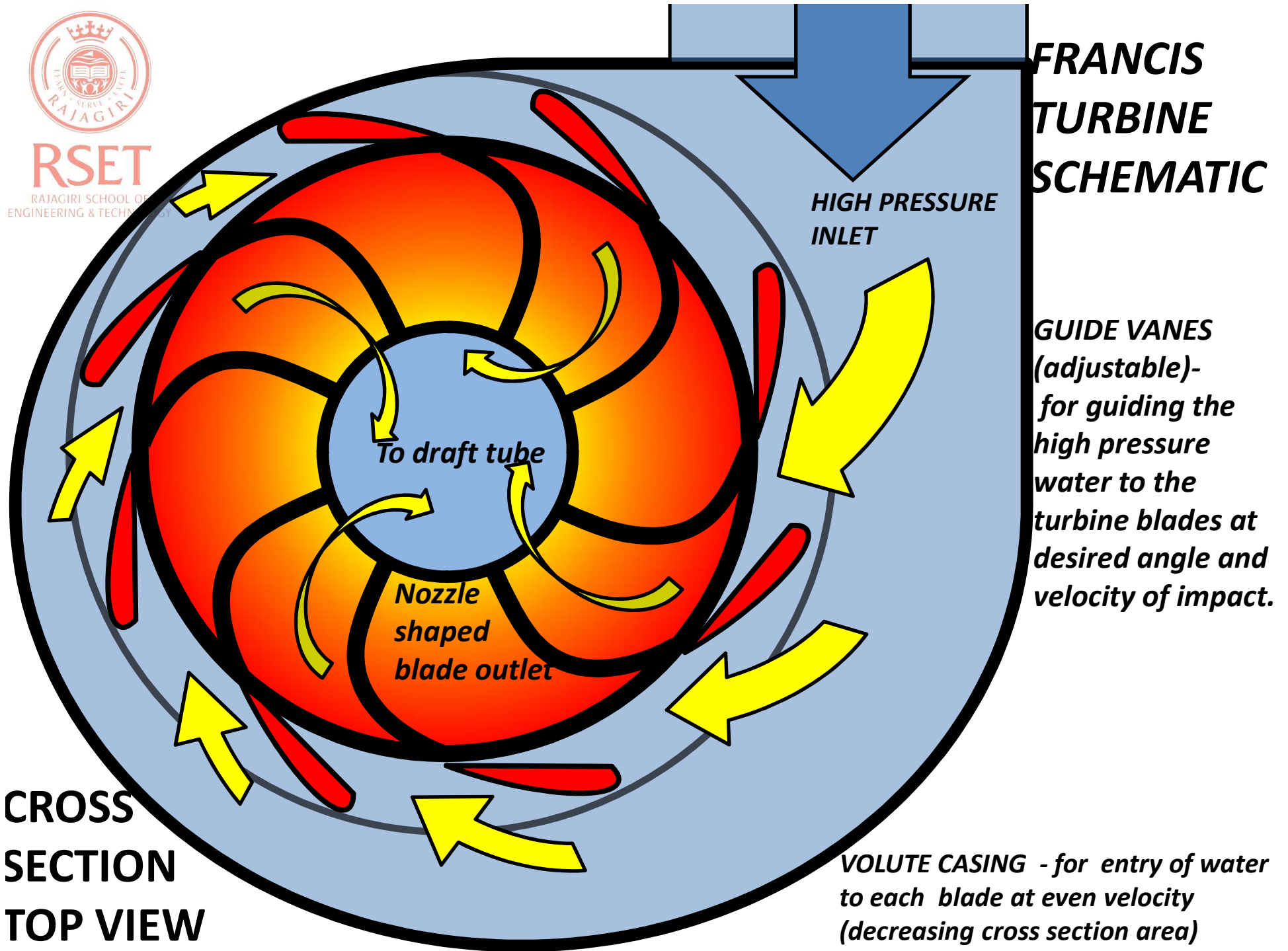

# **REACTION ON FRANCIS TURBINE**

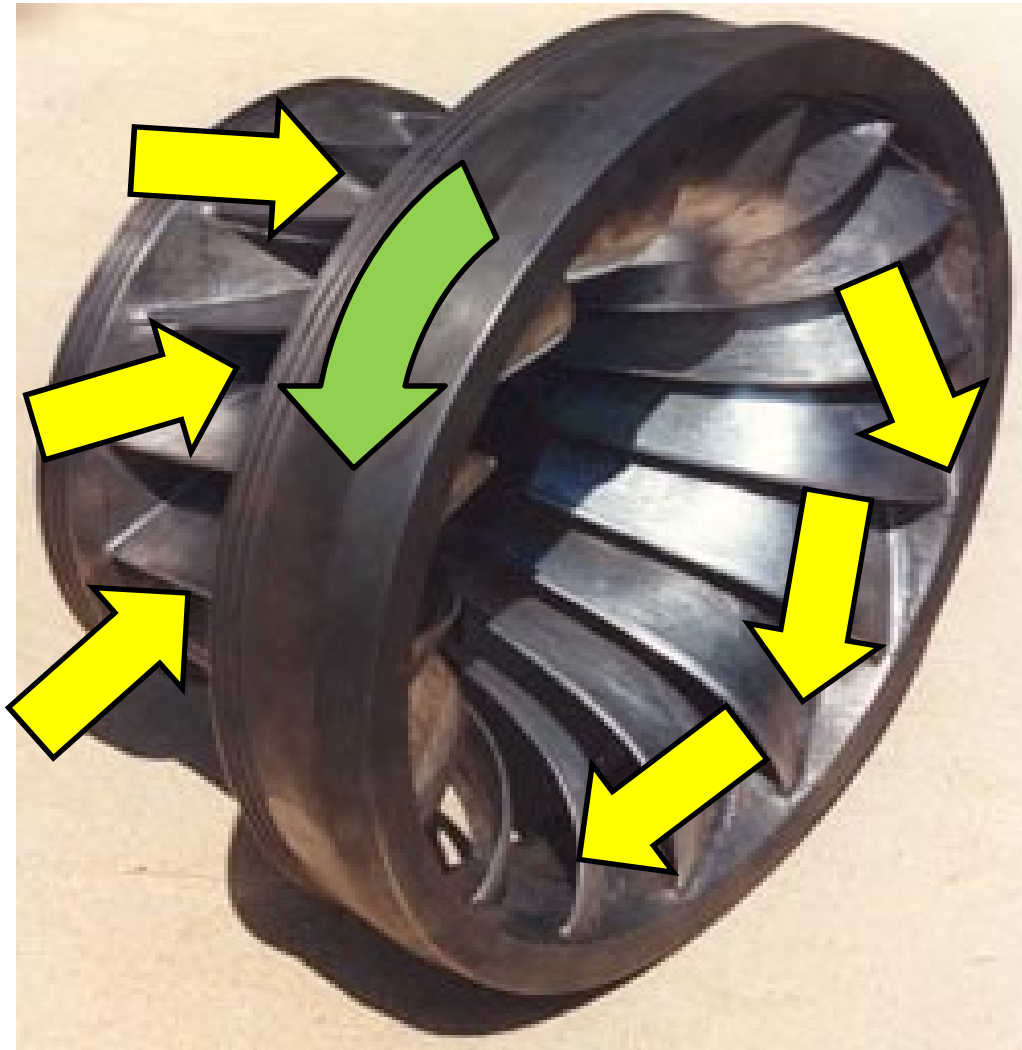

**HIGH PRESSURE  
WATER INLET**

**LOW PRESSURE  
WATER OUT OF  
NOZZLE SHAPED  
BLADES**

# ***GUIDE VANES***



# ***KAPLAN TURBINE***



**POWER  
OUTPUT  
SHAFT**

**KAPLAN (PROPELLER)  
TURBINE cross sectional  
front view**

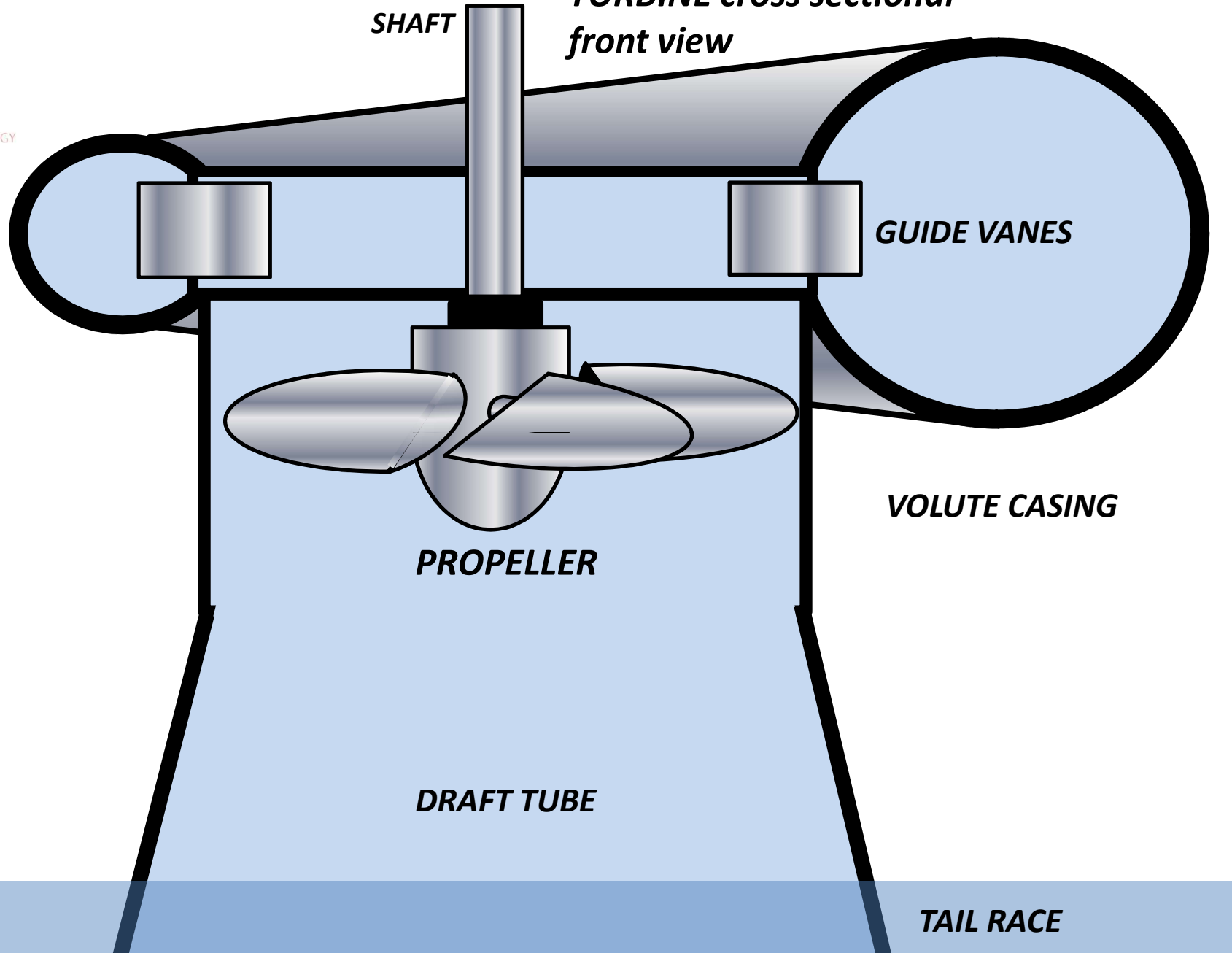

**GUIDE VANES**

**VOLUTE CASING**

**PROPELLER**

**DRAFT TUBE**

**TAIL RACE**

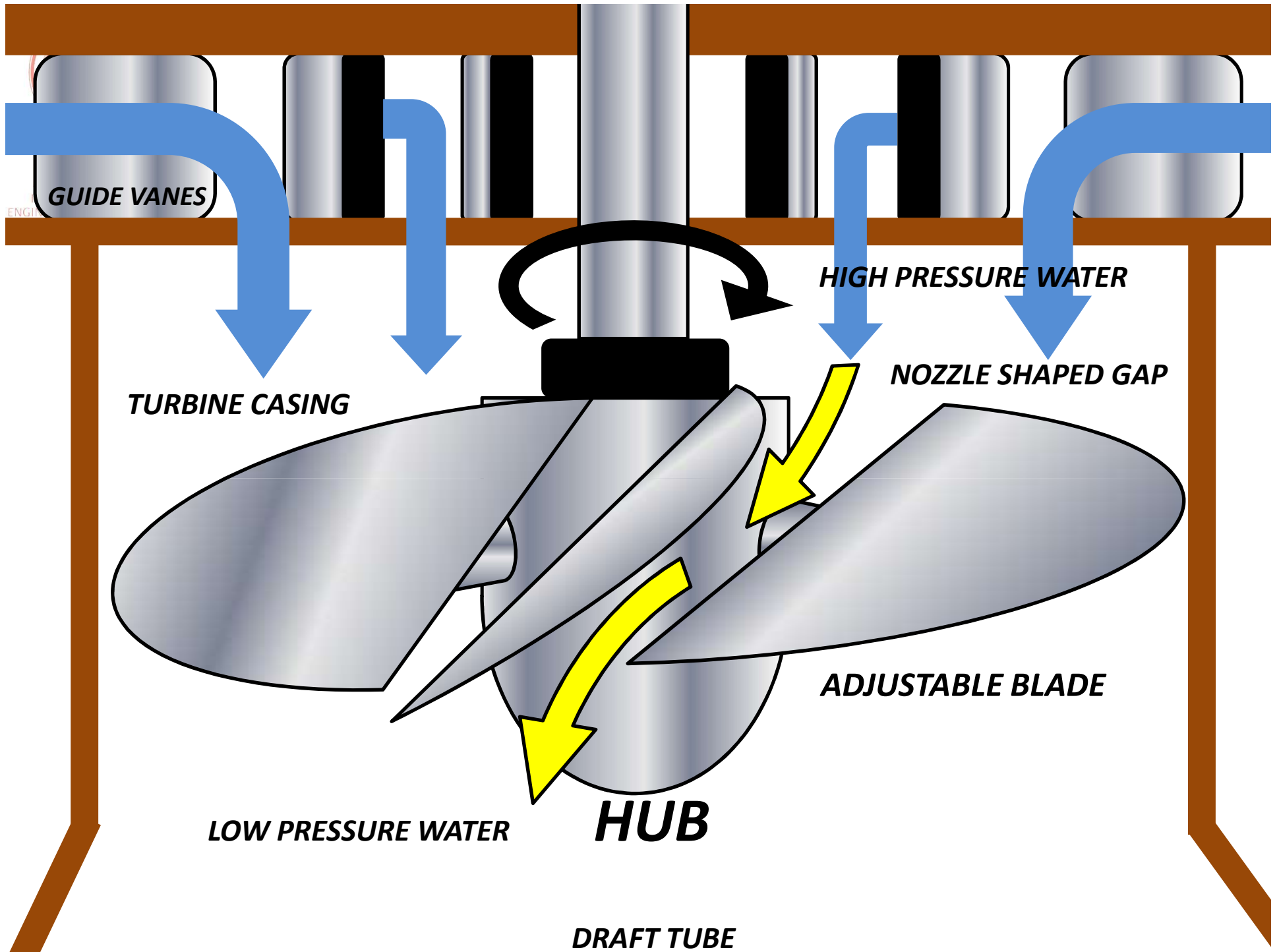

# **GAS TURBINES**

***IMPULSE  
TURBINE***

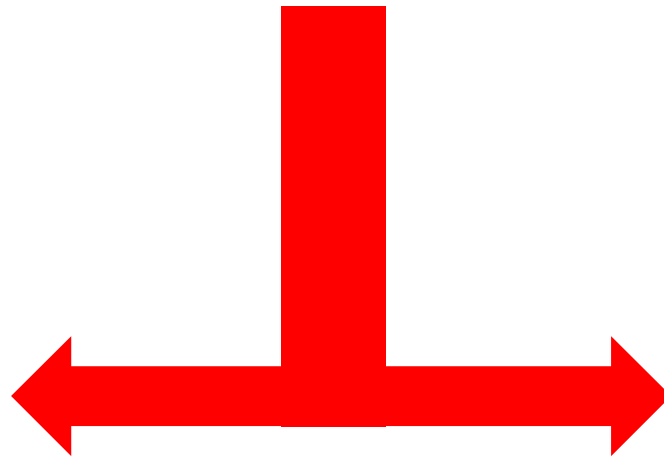

***REACTION  
TURBINE***





**RSET**

RAJAGIRI SCHOOL  
OF ENGINEERING & TECHNOLOGY

# ***IMPULSE STEAM/GAS TURBINE (DE LAVAL TURBINE)***

***BUCKET SHAPED SYMMETRICAL BLADES***



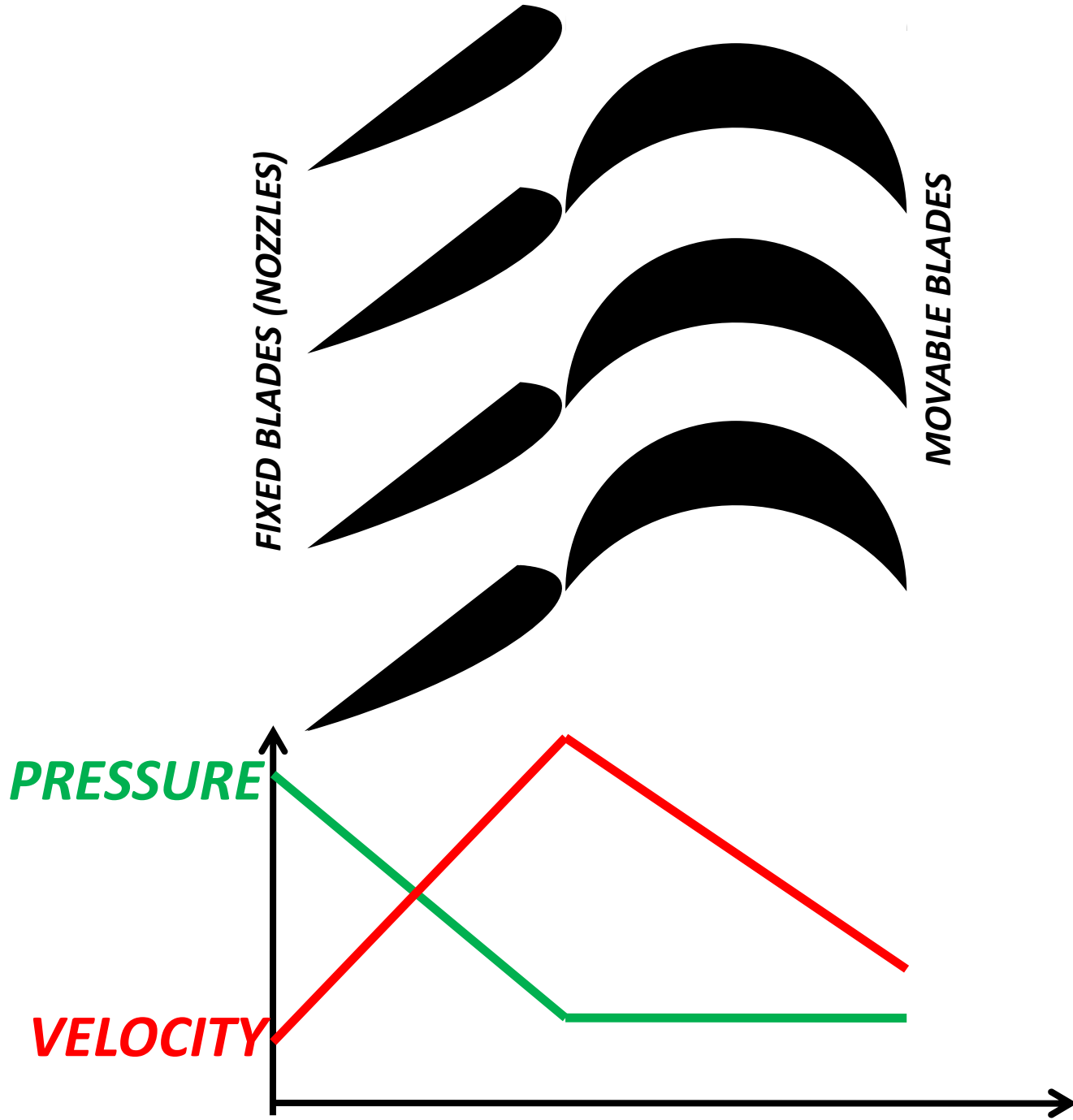



**RSET**  
RAJAGIRI SCHOOL OF  
ENGINEERING & TECHNOLOGY

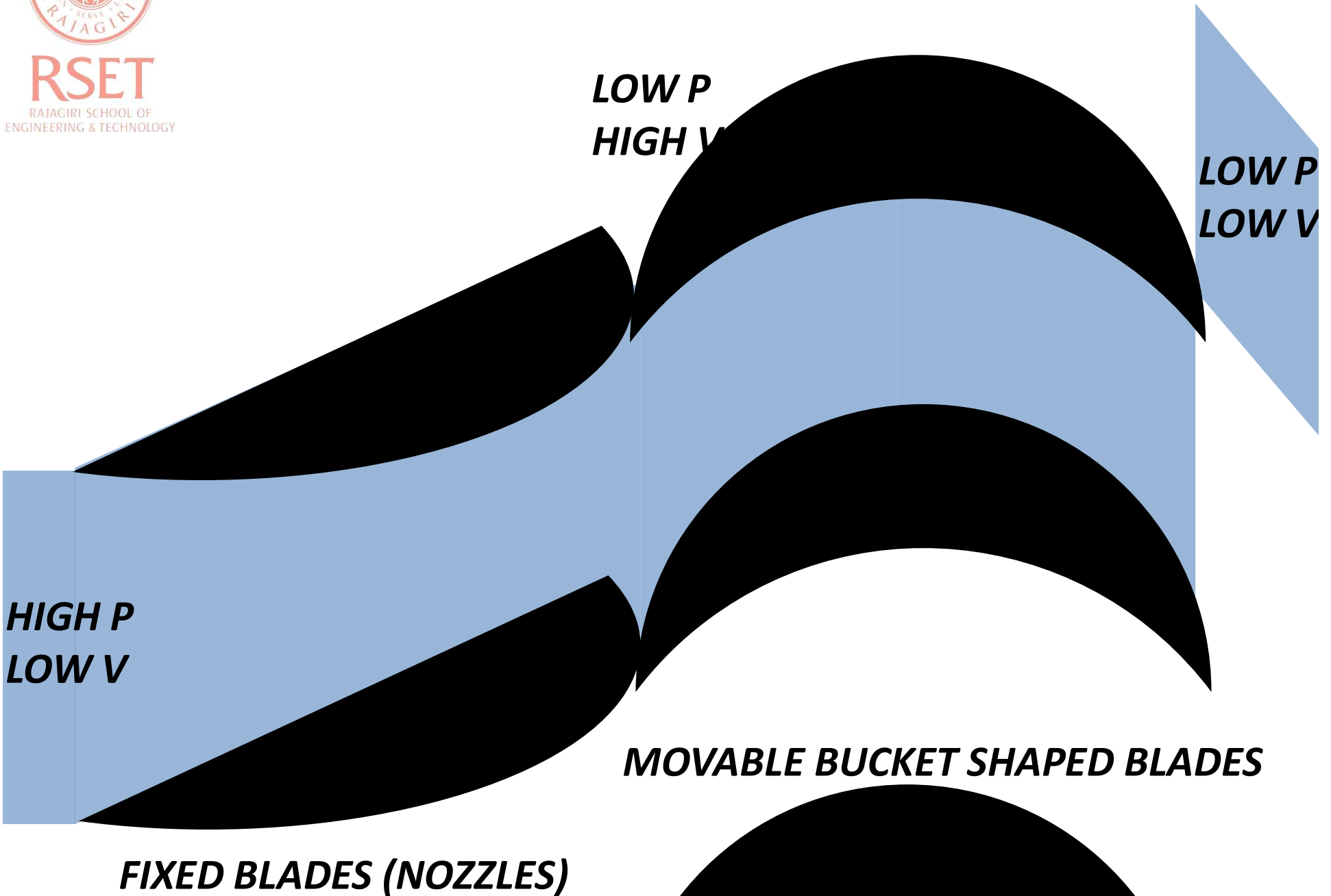

**LOW P**  
**HIGH V**

**LOW P**  
**LOW V**

**MOVABLE BUCKET SHAPED BLADES**

**FIXED BLADES (NOZZLES)**



**RSET**

RAJAGIRI SCHOOL OF  
ENGINEERING & TECHNOLOGY

# **REACTION STEAM/GAS TURBINE (PARSONS TURBINE)**

**AEROFOIL SHAPED  
UNSYMMETRICAL  
BLADES**

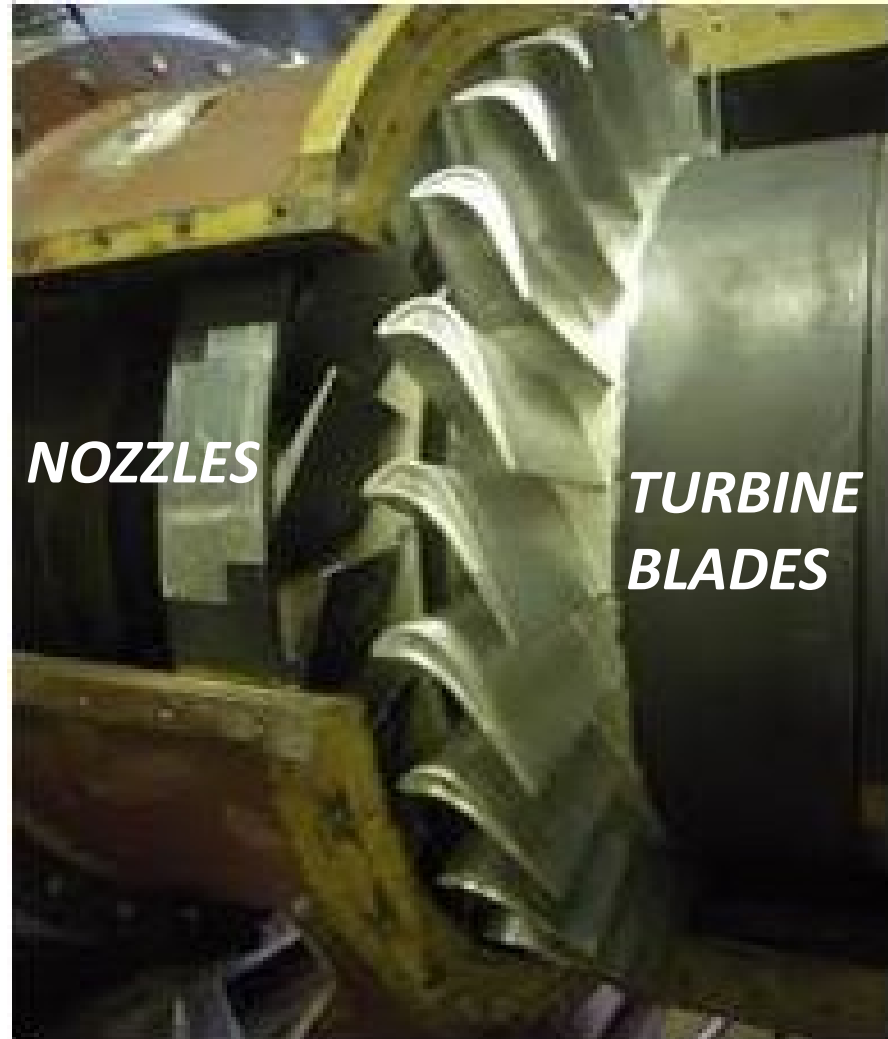

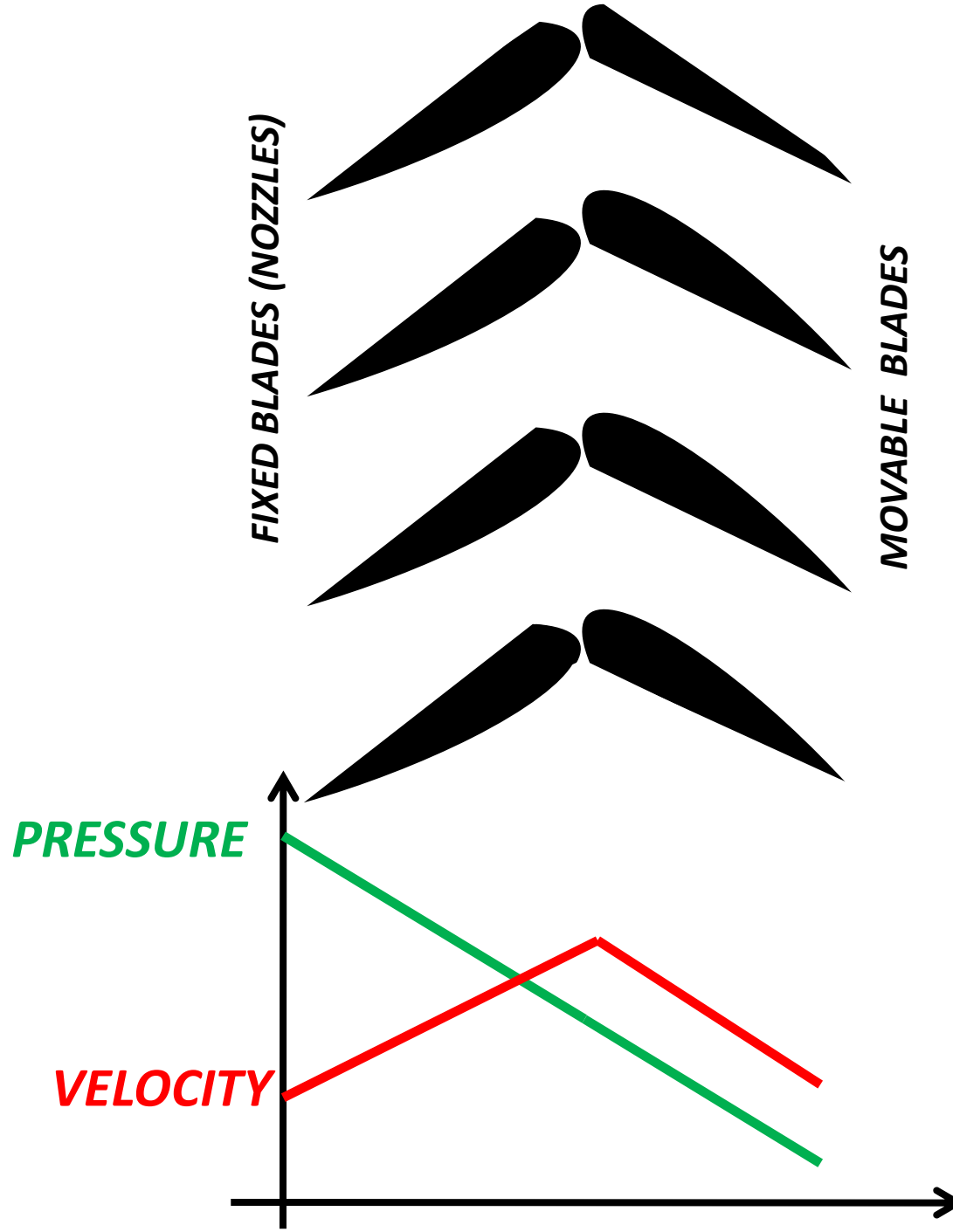



**RSET**  
RAJAGIRI SCHOOL OF  
ENGINEERING & TECHNOLOGY

**MID P**  
**HIGH V**

**LOW P**  
**LOW V**

**HIGH P**  
**LOW V**

**FIXED BLADES (NOZZLES)**

**MOVABLE NOZZLE SHAPED BLADES**

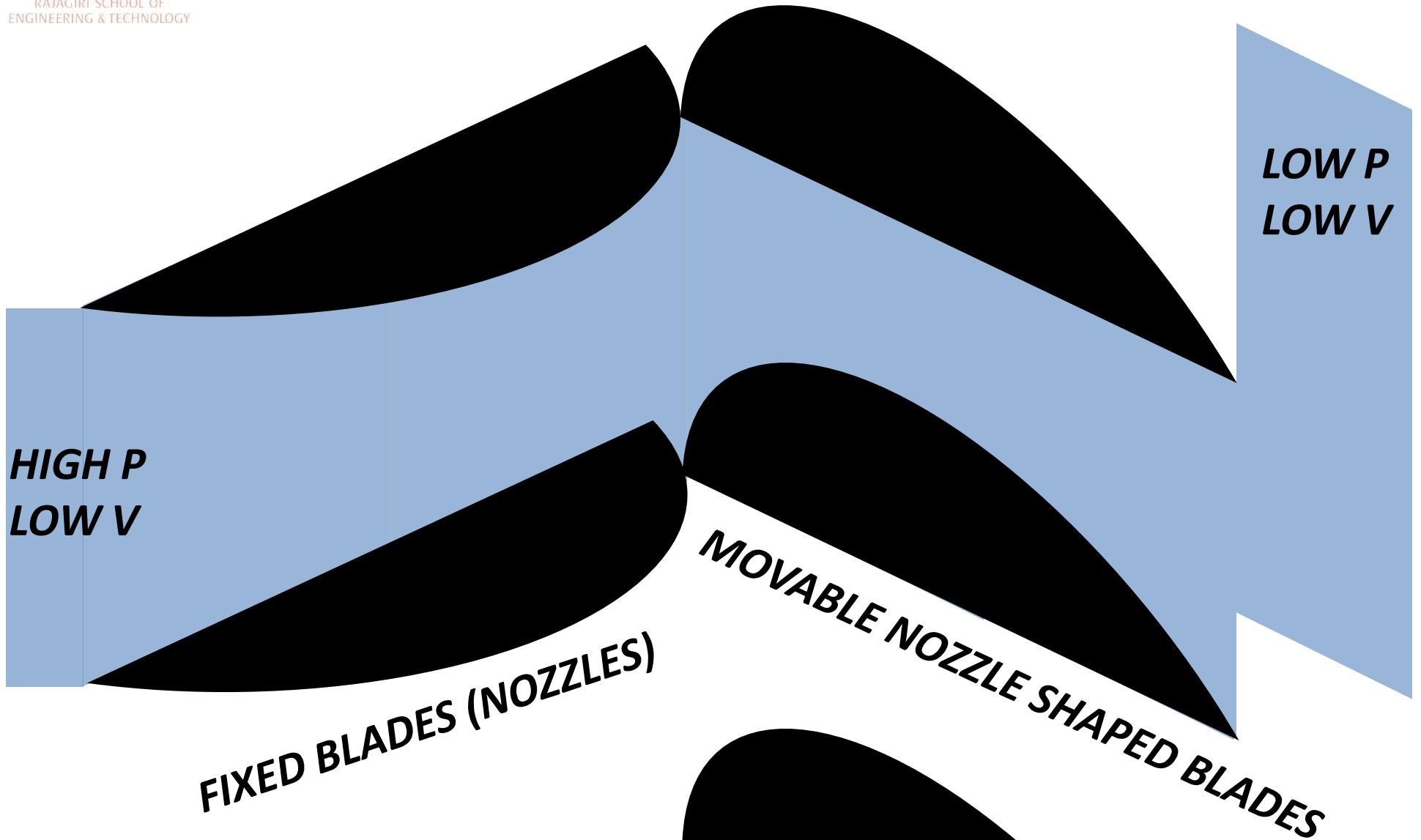



RSET

RAJAGIRI SCHOOL OF  
ENGINEERING & TECHNOLOGY

# IMPULSE TURBINE v REACTION TURBINE

- An impulse turbine has fixed *nozzles* or stator blades in which *pressure energy of fluid is converted to kinetic energy (high velocity)*.
- This high velocity fluid then hits the bucket shaped rotor blades and changes its flow direction and leaves the bucket at low velocity (low KE) *without change in pressure* and as a result an impulsive force is imparted on the buckets.
- Reduction in pressure takes place only in the nozzle
- They operate at *atmospheric pressure*.
- These are low discharge type but *high head is needed for efficient working*.
- Draft tube is useless.



**RSET**

RAJAGIRI SCHOOL OF  
ENGINEERING & TECHNOLOGY

# **IMPULSE TURBINE v REACTION TURBINE**

- A reaction turbines develops torque because of **reaction of blades to change in fluid pressure during its passage through the rotor blades.**
- Reaction force is imparted on the blades as the fluid accelerates through these **nozzle shaped rotor blades.**
- Also impulsive force is imparted on the blades when the high velocity fluid from the nozzles(in gas turbine) or guide vanes (in hydraulic turbine) hits the blades.
- Reduction of pressure takes place in **nozzles(gas turbine) and guide vanes(hydraulic turbine) as well as in the runner blades.**
- They operate at **pressure above atmospheric.**
- These are low head type but **high discharge is needed for efficient working.**
- Draft tube is needed in hydraulic turbines for increasing efficiency.





**RSET**  
RAJAGIRI SCHOOL OF  
ENGINEERING & TECHNOLOGY

# ***IC ENGINES***



**RSET**  
RAJAGIRI SCHOOL OF  
ENGINEERING & TECHNOLOGY

# 4 STROKE PETROL ENGINE PARTS

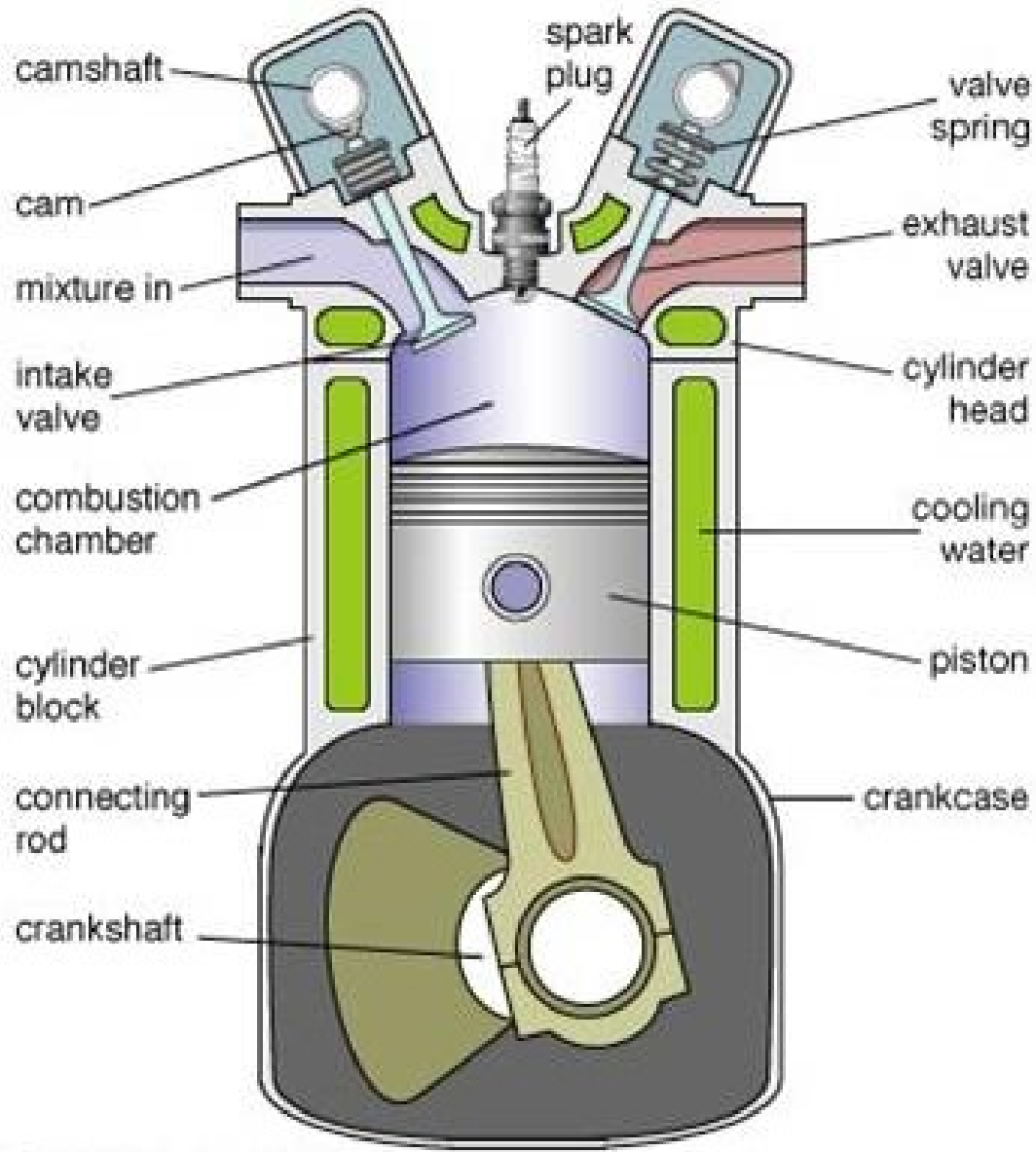

© 2006 Merriam-Webster, Inc.



RSET

RAJAGIRI  
ENGINEERING & TECHNOLOGY

Air  
+fuel

Spark plug

# WORKING OF A 4 STROKE PETROL ENGINE

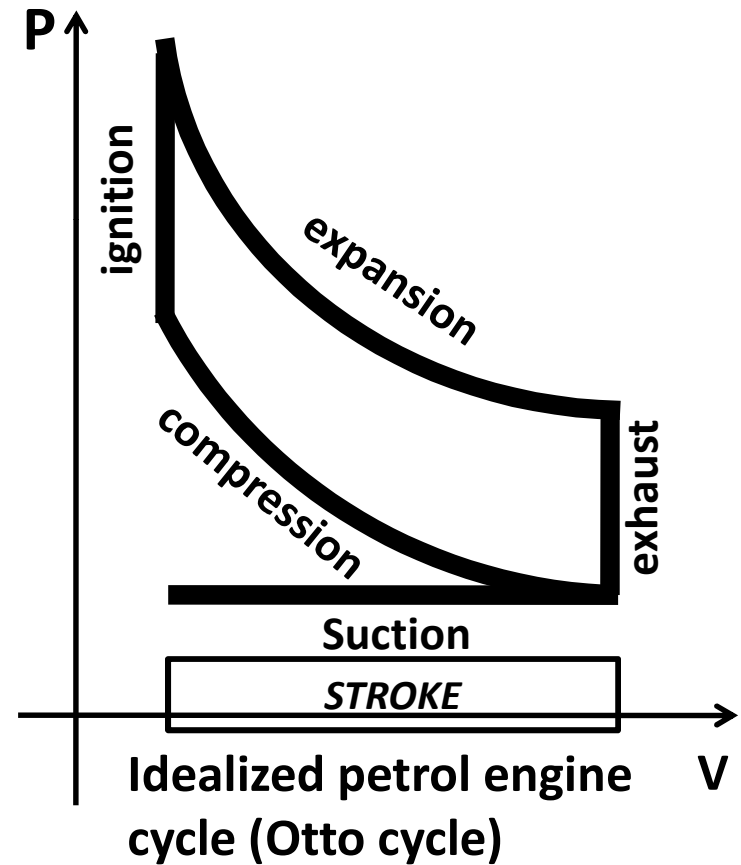
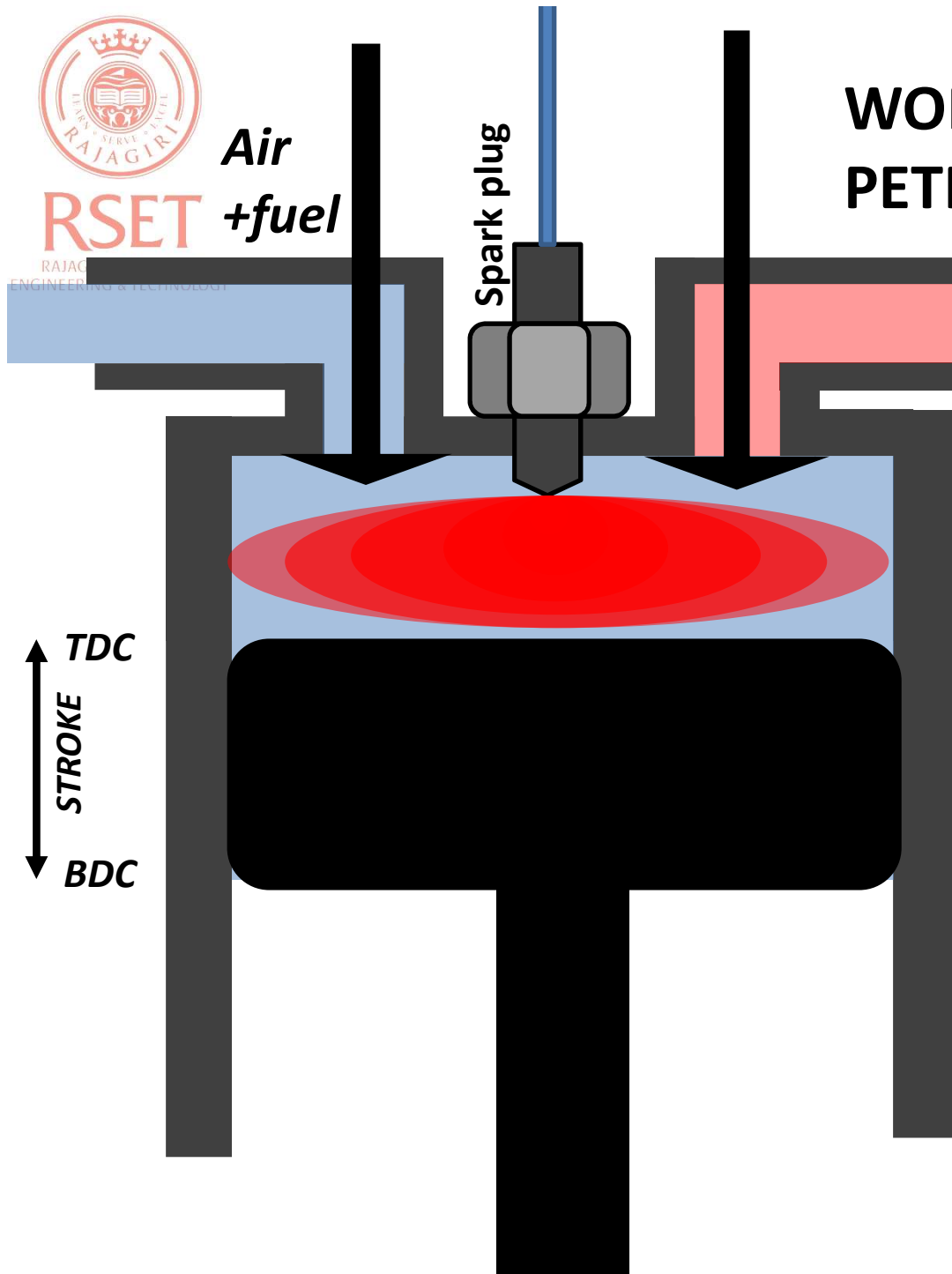



# 4 STROKE PETROL ENGINE WORKING

RSET

RAJAGIRI SCHOOL OF  
ENGINEERING & TECHNOLOGY

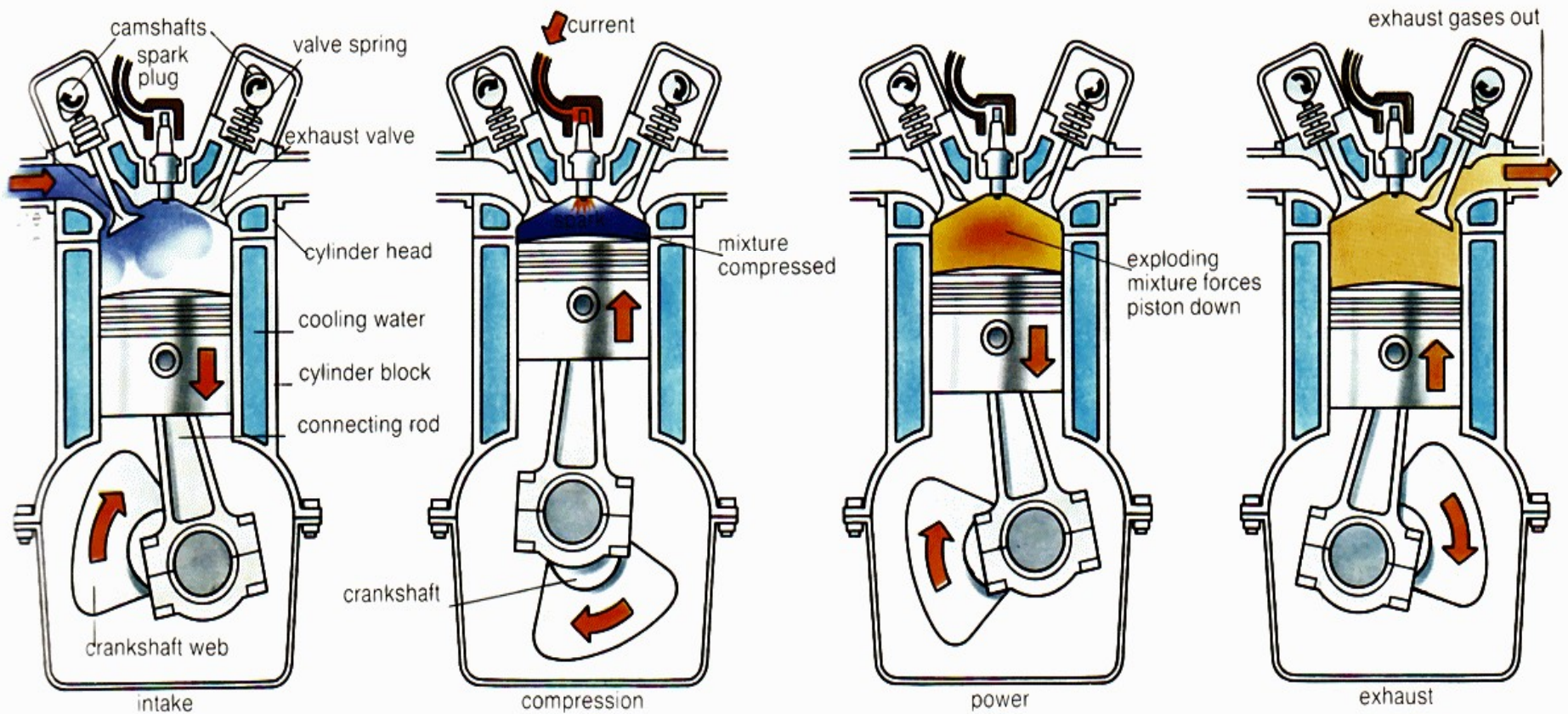



**RSET**

RAJAGIRI SCHOOL OF  
ENGINEERING & TECHNOLOGY

# 4 STROKE DIESEL ENGINE PARTS

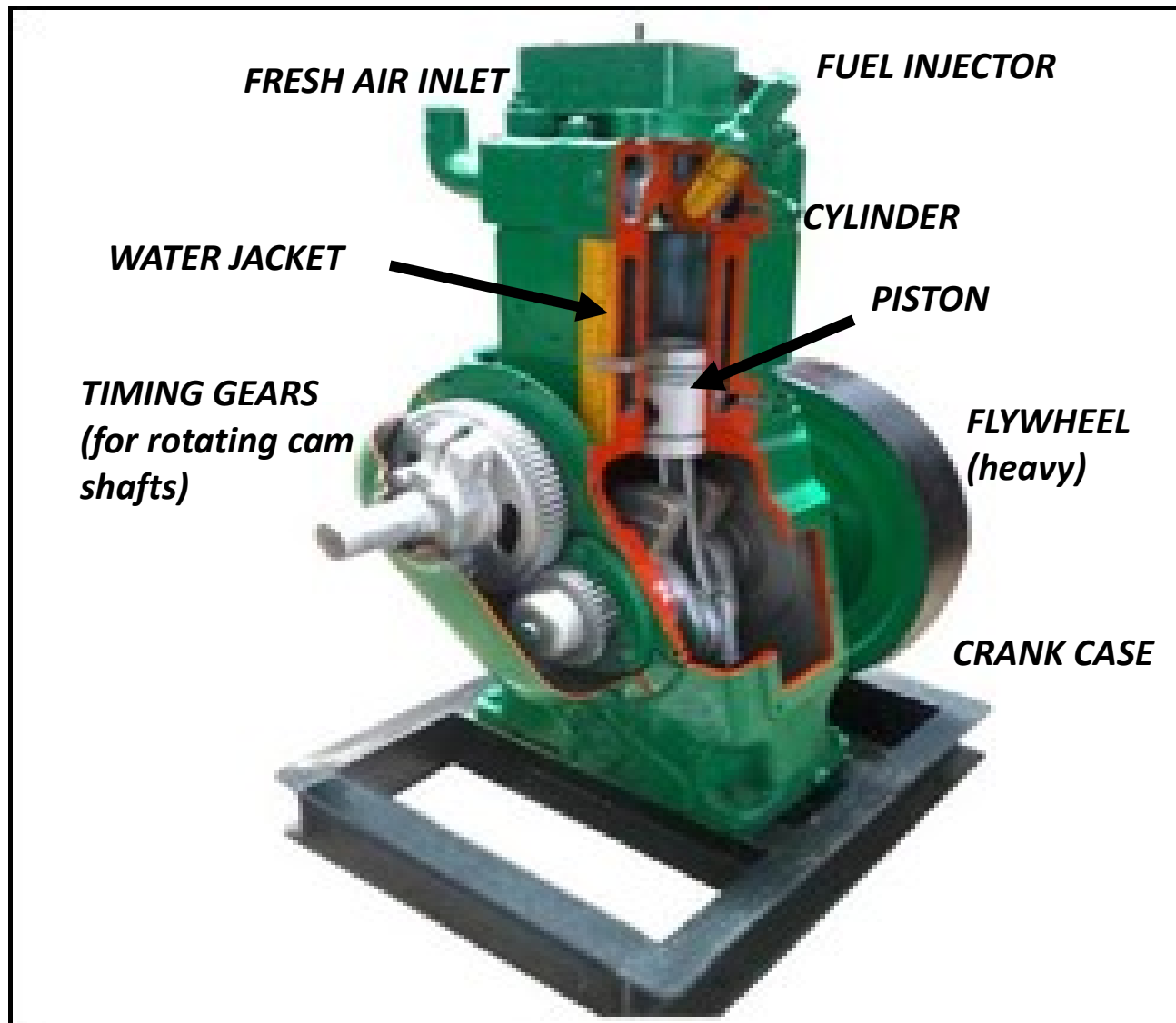



**RSET**

RAJAGIRI SCHOOL  
ENGINEERING & TECH

# 4 STROKE DIESEL ENGINE WORKING

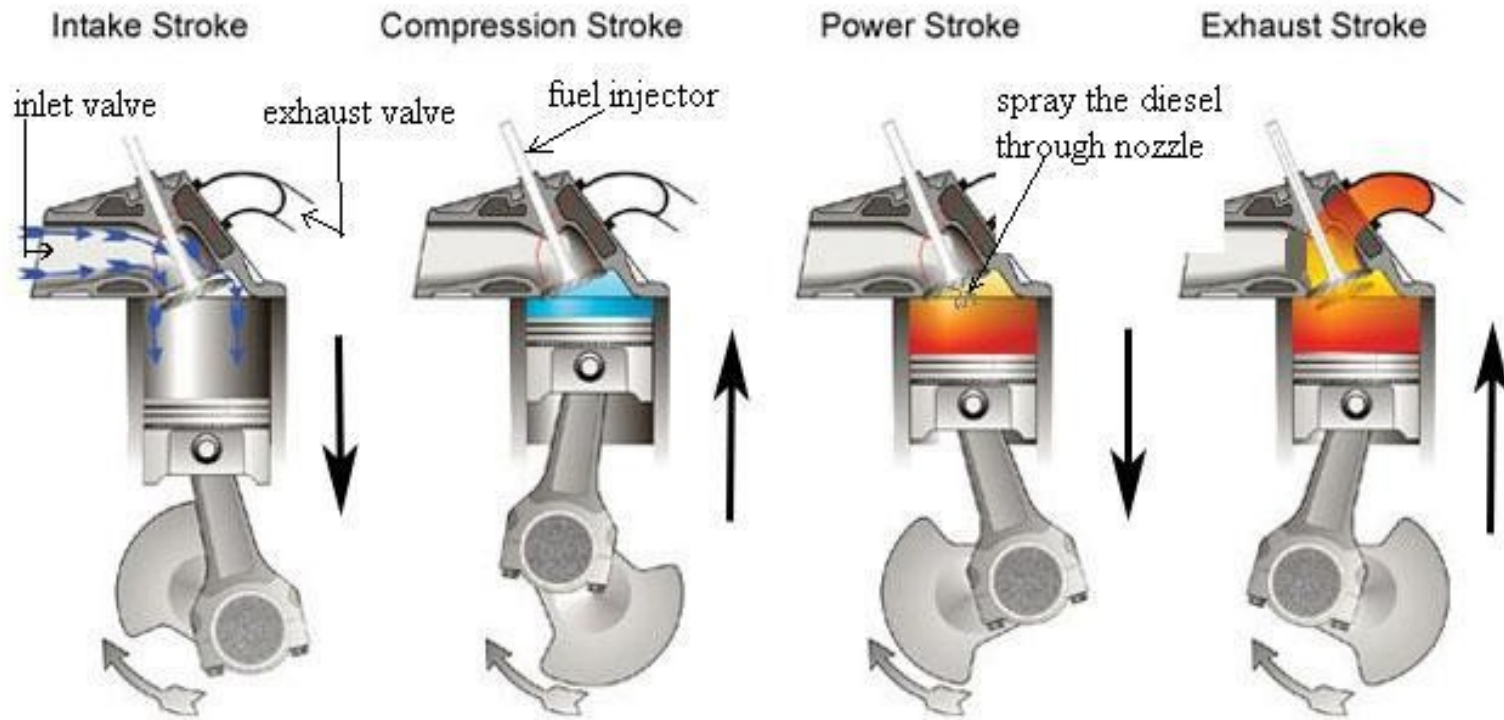



RSET  
RAJAGIRI  
ENGINEERING & TECHNOLOGY

Air

Fuel injector

# WORKING OF A 4 STROKE DIESEL ENGINE

TDC  
STROKE  
BDC

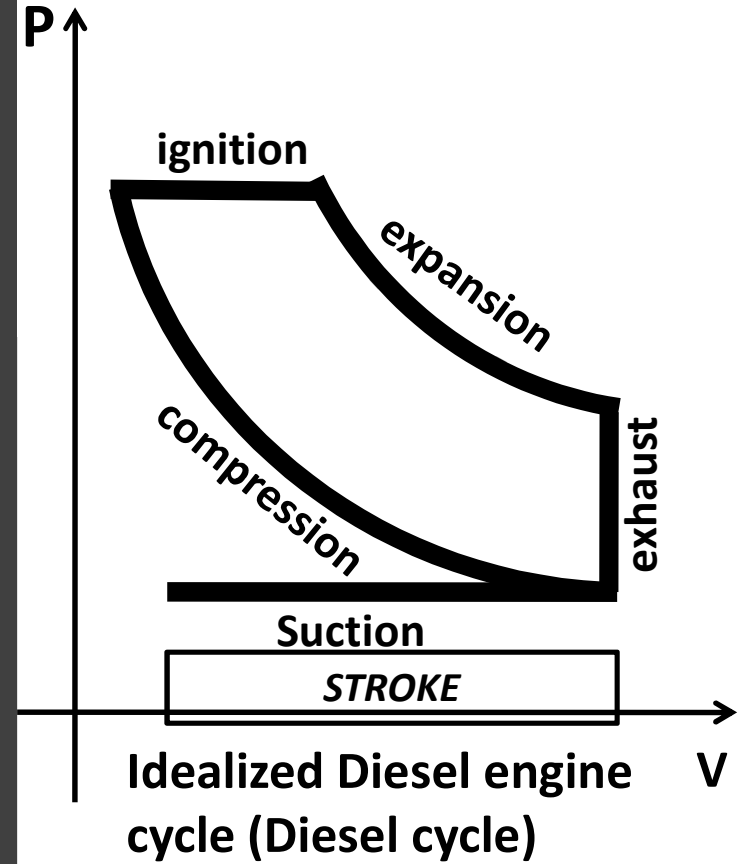
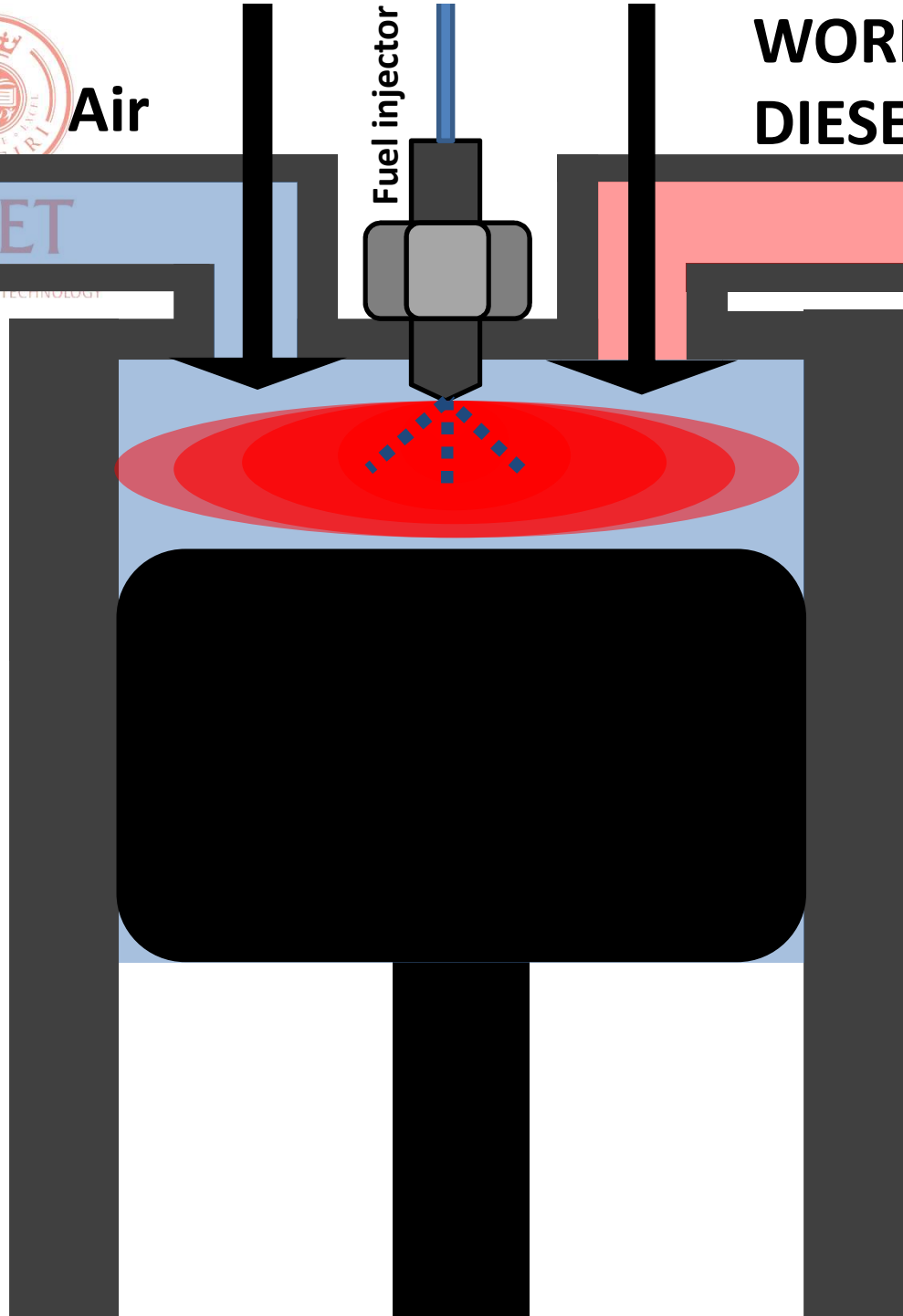



**RSET**

RAJAGIRI SCHOOL OF  
ENGINEERING & TECHNOLOGY

# ***PETROL ENGINES v DIESEL ENGINES***

<b>S.I. ENGINE</b>	<b>C.I. ENGINE</b>
Works on Otto cycle	Works on Diesel cycle
Gasoline is used as fuel	Diesel is used as fuel
A gaseous mixture of fuel and air is introduced with the help of carburetor	Fuel is injected directly onto the combustion chamber with help of fuel injector
It is quantity controlled	It is quality controlled
Requires an ignition system with spark plug in the combustion chamber	Self ignition occurs because of high compression
Compression ratio changes from 6-10	Compression ratio changes from 16-20
Lower weight due to low pressure developed	Heavy weight due to higher compression ratio
Due to light weight ,they are high speed engine	Due to heavy weight, they are slow speed engine.





**RSET**

RAJAGIRI SCHOOL OF  
ENGINEERING & TECHNOLOGY

# ***PETROL ENGINE V DIESEL ENGINES***

<b>Sl. No.</b>	<b>Petrol Engine</b>	<b>Diesel Engine</b>
1.	The exhaust is less noisy.	The exhaust is noisy due to short time available for exhaust.
2.	Intake (petrol) and air is admitted into the cylinder during suction stroke.	Air alone is admitted into the cylinder during suction stroke.
3.	Fuel Ignition: - By spark plug-spark Ignition (SI) engine.	By the compressed hot air compression Ignition (CI) engine.
4.	Cycle of operation:- Otto cycle (constant volume cycle)	Diesel cycle.
5.	Compression Ration Low (7 to 8).	High (16 to 17).
6.	Fuel admission through carburetor.	Through fuel injector.
7.	Engine speed:- high speed; can run up to 5000 rpm since petrol engine is lighter.	Low speed; about up to 3500 rpm.



**RSET**

RAJAGIRI SCHOOL OF  
ENGINEERING & TECHNOLOGY

# QUANTITY AND QUALITY CONTROL OF ENGINE

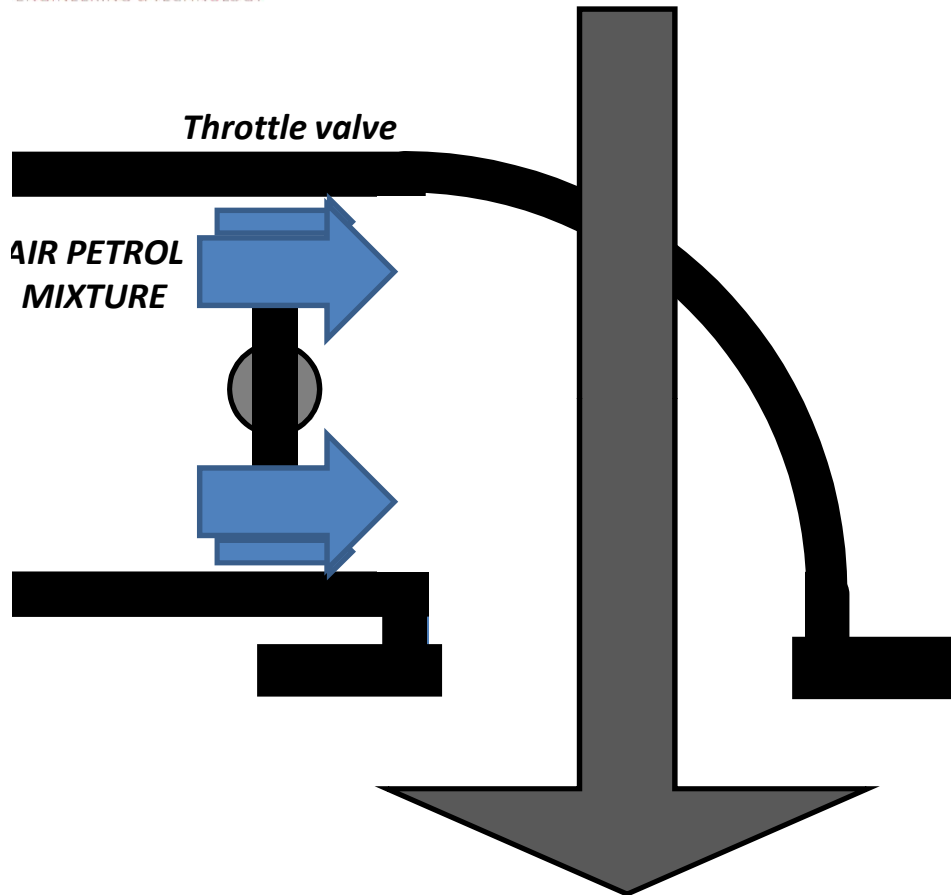

*In SPARK IGNITION engines speed is controlled by adjusting the throttle valve. i.e. adjusting the quantity of air fuel mixture.*

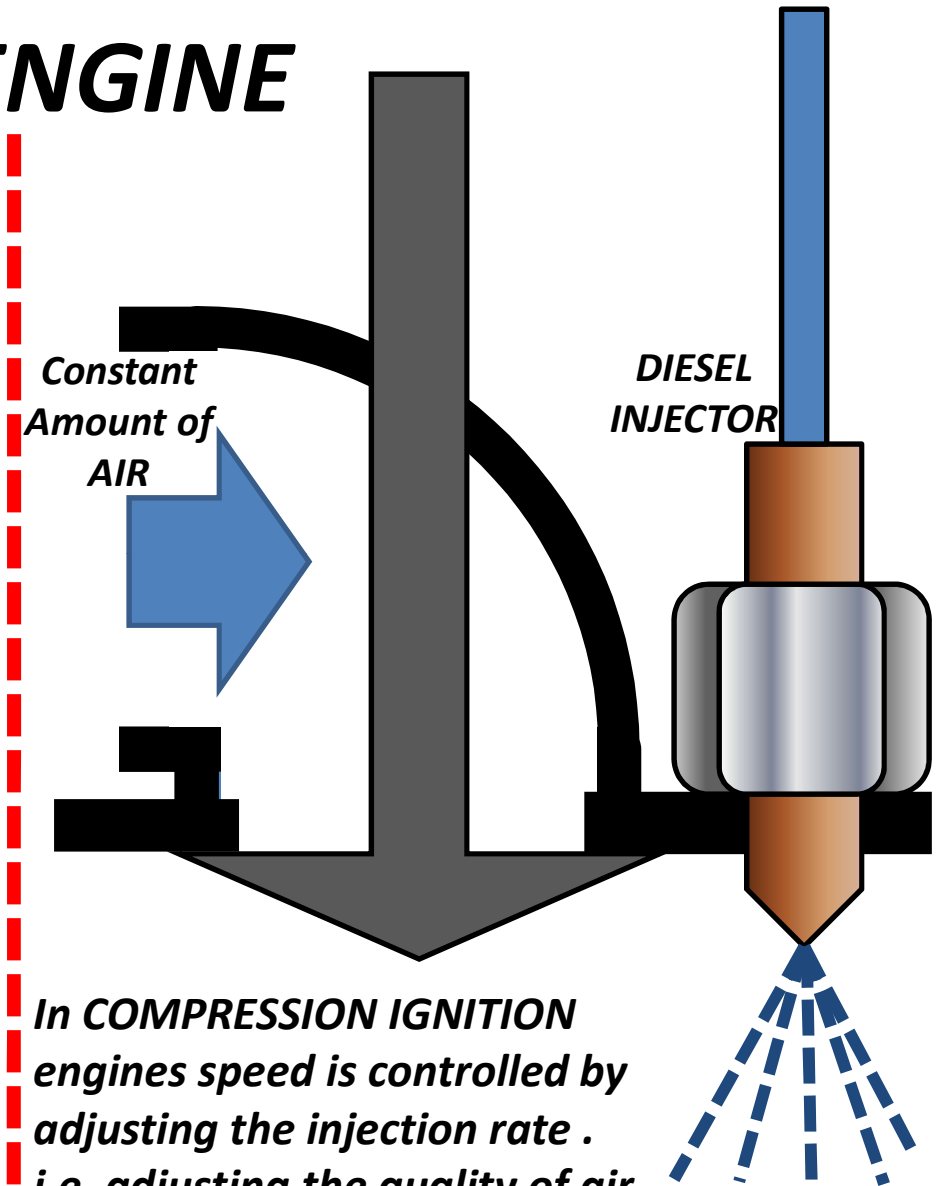

*In COMPRESSION IGNITION engines speed is controlled by adjusting the injection rate . i.e. adjusting the quality of air fuel mixture.*



**RSET**  
RAJAGIRI SCHOOL OF  
ENGINEERING

# 2 STROKE ENGINE PARTS

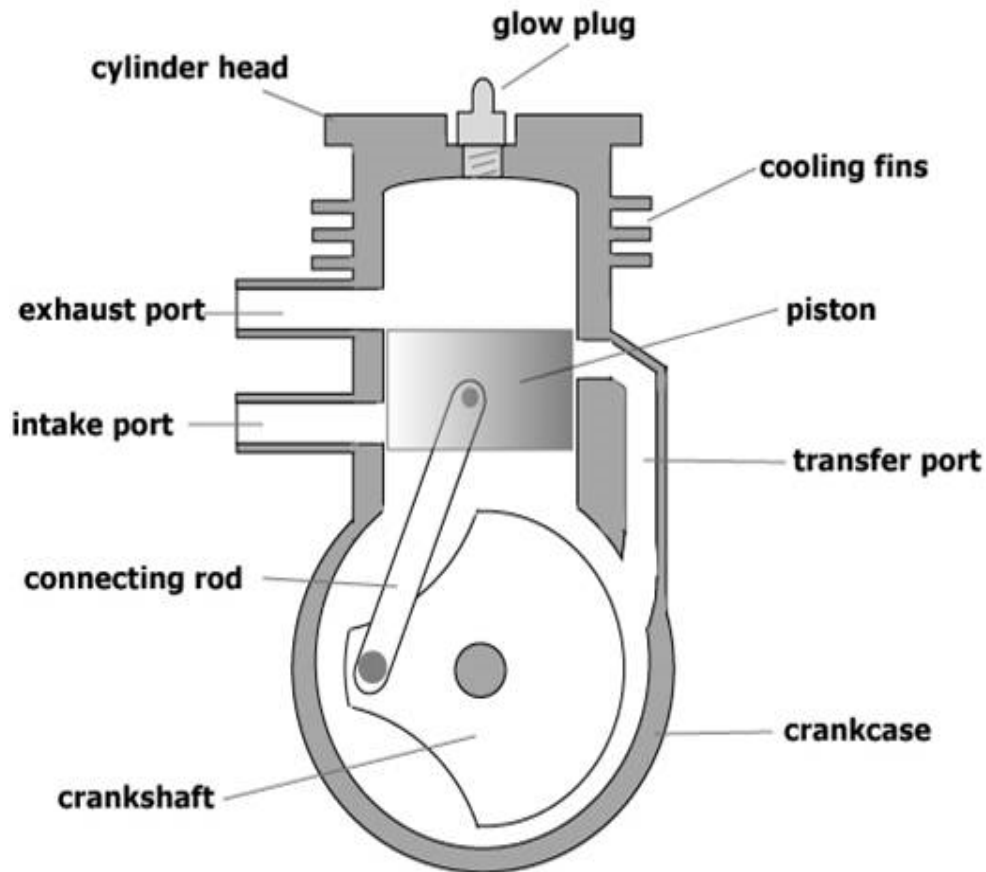

Copyright©2005 RC Airplane Advisor





RSET

RAJAGIRI ENGINEERING COLLEGE

# 2 STROKE ENGINES

## cross section schematic

### PETROL ENGINE

### DIESEL ENGINE

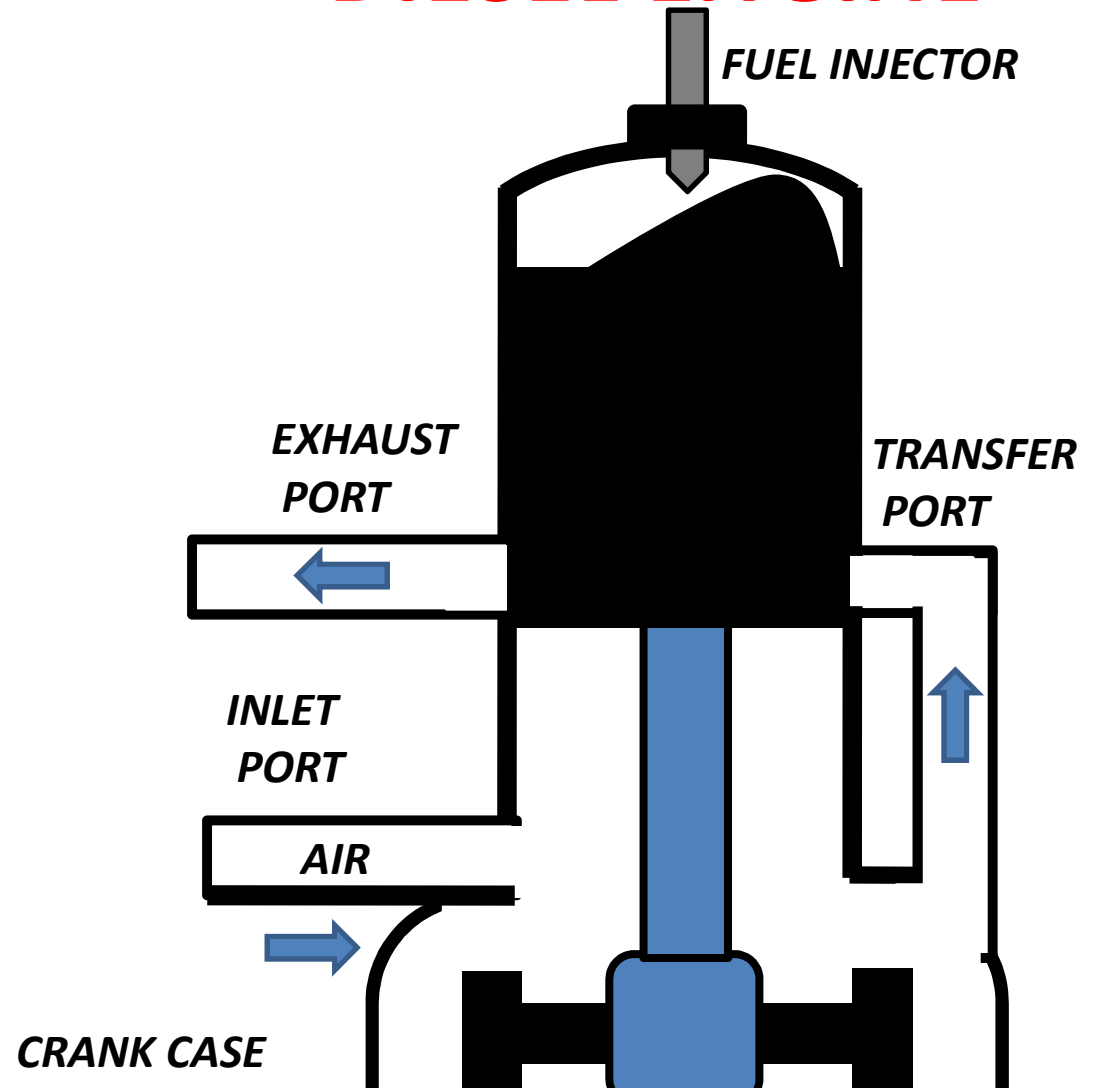
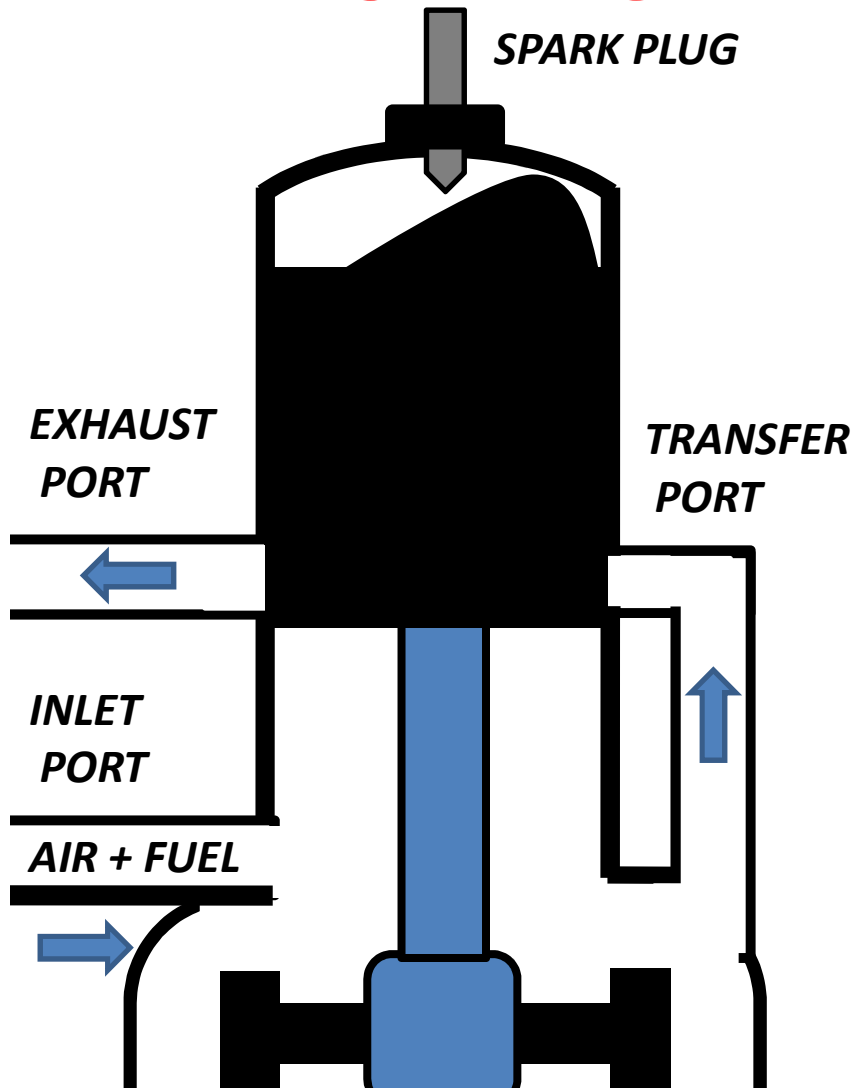



**RSET**  
SCHOOL OF  
**EXHAUST**  
ENGINEERING & TECHNOLOGY

**PETROL ENGINE    DIESEL ENGINE**

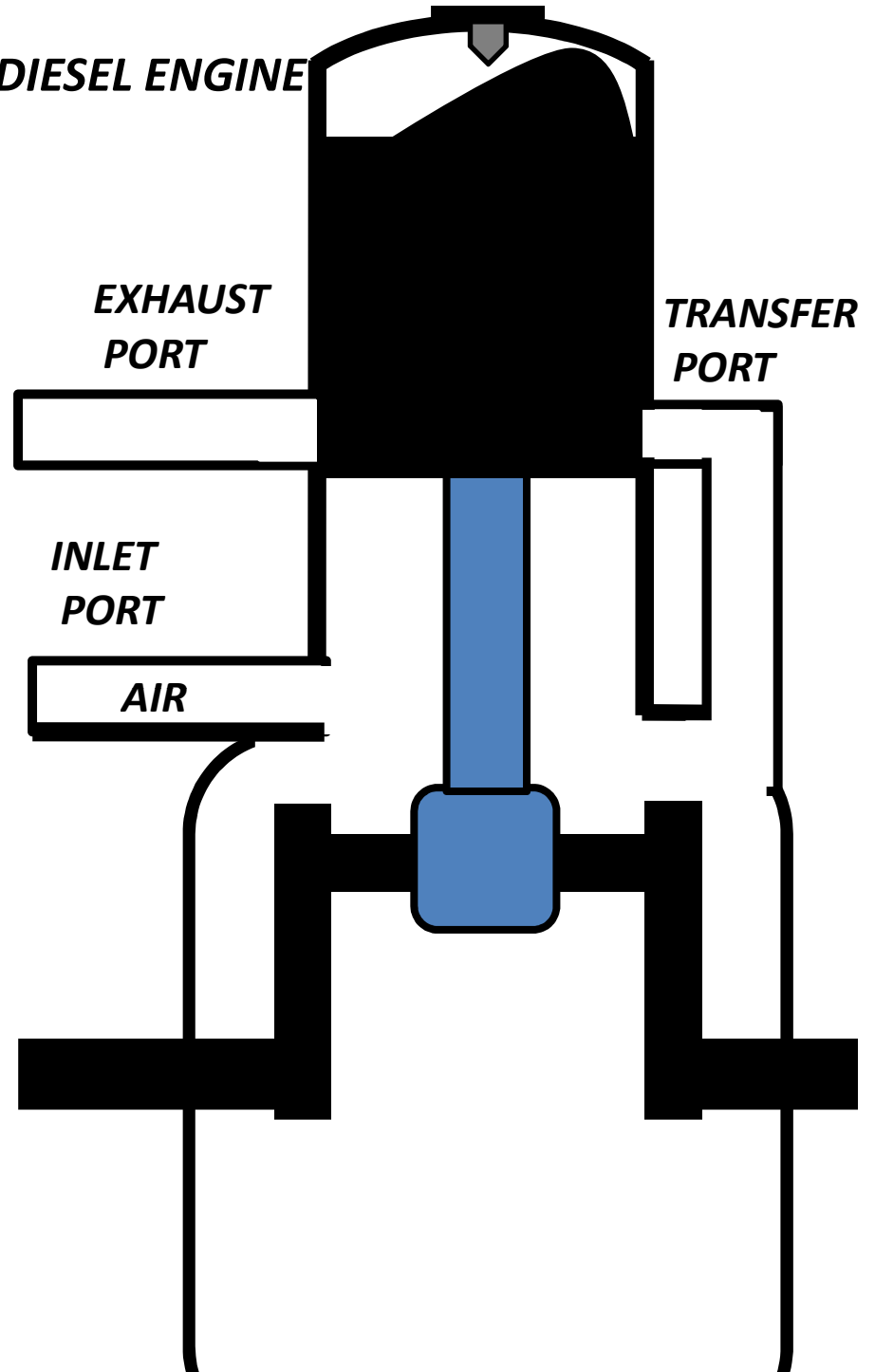
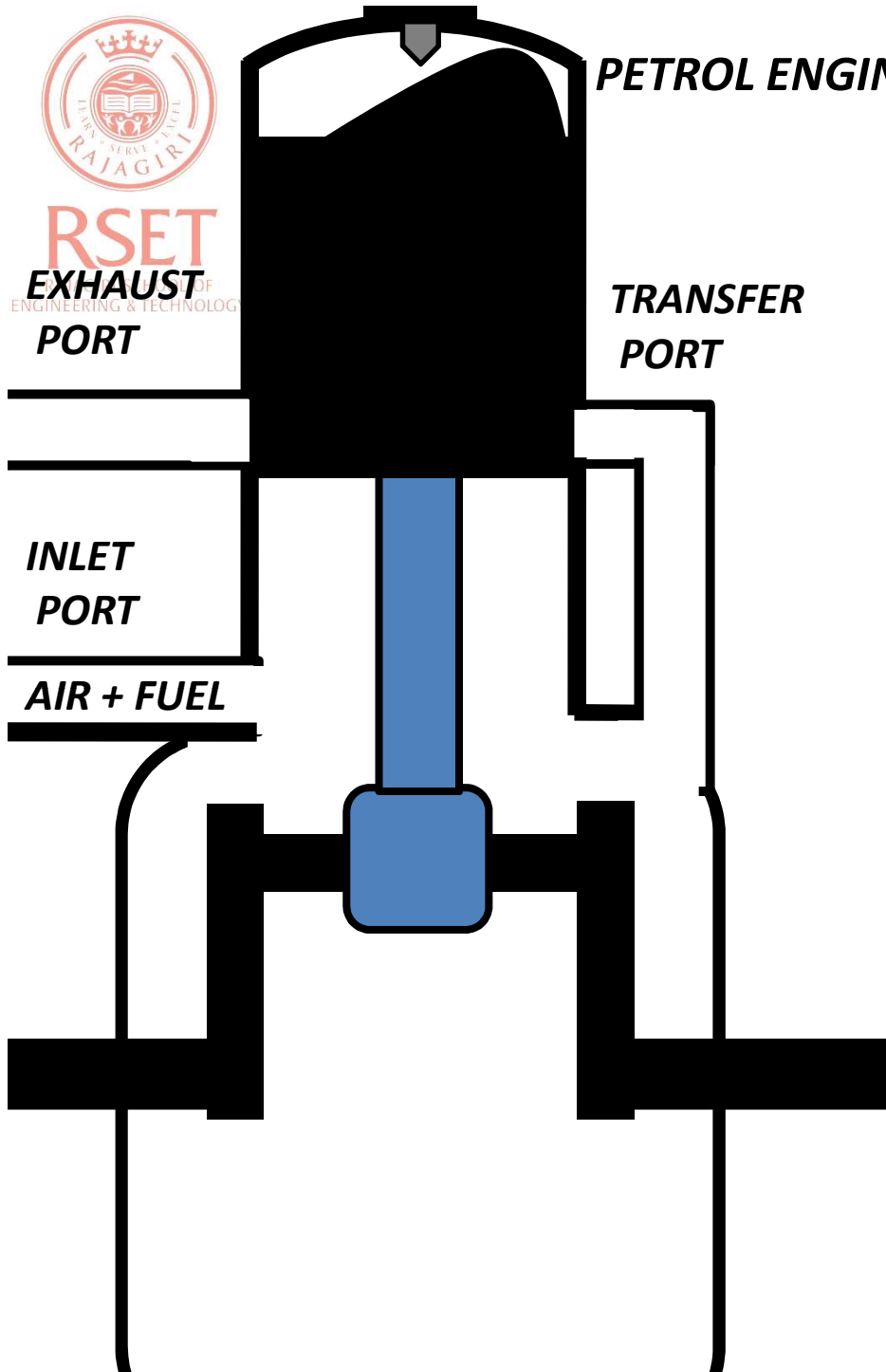



**RSET**  
RAJAGIRI SCHOOL OF  
ENGINEERING & TECHNOLOGY

# 2 STROKE ENGINE WORKING (petrol)

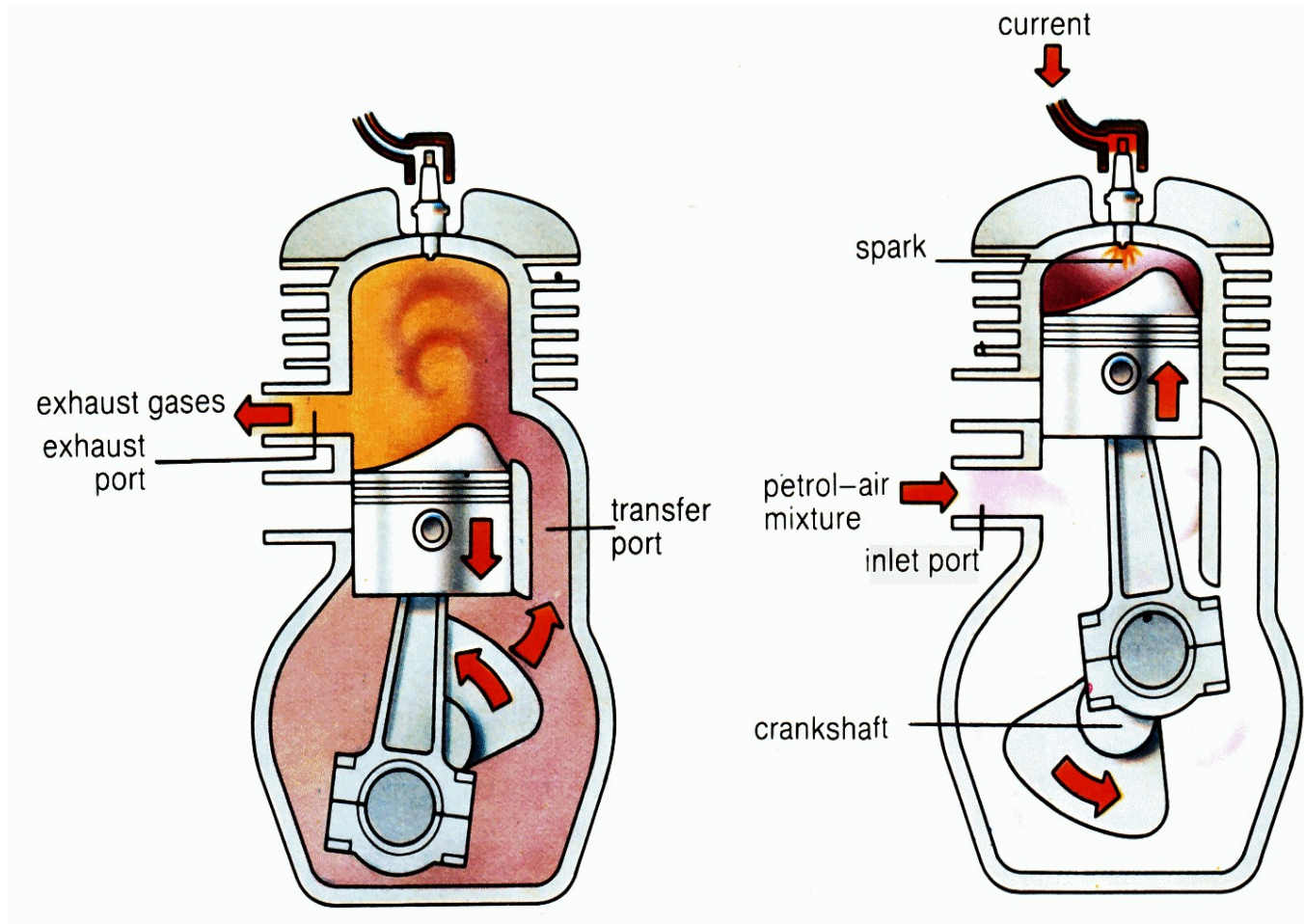



**RSET**

RAJAGIRI SCHOOL OF  
ENGINEERING & TECHNOLOGY

# 4 STROKE VS 2 STROKE ENGINES

Sl. No.	Four stroke cycle engine	Two stroke cycle engine
1.	For every two revolutions of the crankshaft, there is <b>one power stroke</b> i.e., after <b>every four piston strokes</b> .	For every one revolution of the crankshaft, there is one power stroke i.e., <b>after every two piston strokes</b> .
2.	For same power, <b>more space is required</b> .	For the same power <b>less space is required</b> .
3.	Valves are required – <b>inlet and exhaust valves</b> .	Ports are made in the cylinder walls – <b>inlet, exhaust and transfer port</b> .
4.	As the valves move frequently, <b>lubrication is essential</b> .	Arrangement of ports, <b>reduce wear and tear and lubrication is not very essential</b> .



**RSET**

RAJAGIRI SCHOOL OF  
ENGINEERING & TECHNOLOGY

# 4 STROKE VS 2 STROKE ENGINES

5.	Heavier flywheel is required because the turning moment (torque) of the crankshaft is not uniform i.e. one working stroke in every two revolution.	Lighter flywheel is required because the turning moment of the crankshaft is much more uniform i.e. one working stroke for every revolution.
6.	These engines are water cooled, making it complicated in design and difficulty to maintain	These engines are generally air cooled, simple in design and easy to maintain.
7.	The fuel-air charge (mixture) is completely utilized thus efficiency is higher	As inlet and outlet port open simultaneous, some times fresh charge escapes with the exhaust gases are not always completely remove. This causes lower efficiency.





**RSET**

RAJAGIRI SCHOOL OF  
ENGINEERING & TECHNOLOGY

# **4 STROKE VS 2 STROKE ENGINES**

9	Used in heavy vehicles, examples: Buses, Lorries, trucks etc.	Used in light vehicles, examples: Motor cycles, Scooters, Mopeds etc.
10.	Heavy structure.	Compact and light.
11.	The engine cost more.	The engine cost less.

# ***PUMPS***

***A DEVICE USED TO INCREASE  
THE PRESSURE AND FOR  
DISPLACEMENT OF A LIQUID***

***ROTARY  
PUMPS***

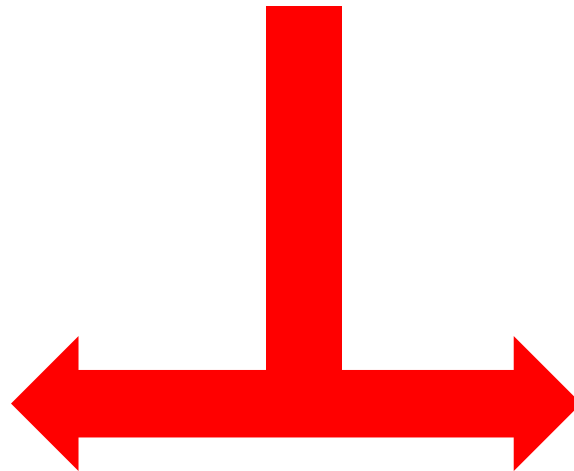

***ROTO-DYNAMIC  
PUMPS***



# **ROTARY PUMPS**

**RSET**  
RAJAGIRI  
ENGINEERING & TECHNOLOGY

*E.g. Plunger pumps, Reciprocating pumps, Gear pumps, Screw pumps etc*

- *These are called positive displacement pumps*
- *while working of the pump there is always discharge of the fluid. When discharge valve is closed, pump stops working or there will be failure of system. i.e. Discharge of fluid cannot be controlled by adjusting the discharge valves.*
- *These pumps are used for low discharge and high pressure.*
- *They can be used for high viscosity fluids.*



# **ROTARY PUMPS**

- *Priming (filling pump casing and suction pipe with working fluid) rarely needed.*
- *Cannot be directly coupled to motors because of high torque requirement and low speed, fly wheel is needed because rotation speed is not uniform (high torque during discharge stroke and low torque during suction stroke). E.g. reciprocating pump.*

*Applications: Pumping small quantities of viscous liquid fuels into high pressure combustion chambers.*

*Sucking petroleum products and mud out from deep oil rigs.*



# **ROTO-DYNAMIC PUMPS**

*E.g. centrifugal pumps*

- *They are called non- positive displacement pumps*
- *while working of the pump there may or may not be a discharge of the fluid. i.e. Discharge of the fluid can be controlled by adjusting the discharge valves.*
- *These pumps are used for high discharge and low pressure. They are less efficient at low discharge and high pressure.*
- *Priming is necessary. Because suction pressure depends on the density of working fluid. So if any low density fluid (like air) is present in the pump casing or at suction side, suction pressure will be less and high density working fluid cannot be pumped.*



# **ROTO-DYNAMIC PUMPS**

- *Max suction pressure is limited by a phenomenon called **cavitations** which damages the impellers. So it cannot be used for deep sumps.*
- *Can be directly coupled to motors because of low torque and high speed operation and no need of a fly wheel because rotation speed is uniform.*

*Applications: pumping large quantities of low viscous fluids(water) at low pressure from shallow sumps for house hold and industrial uses.*

# **RECIPROCATING PUMP cross section schematic**

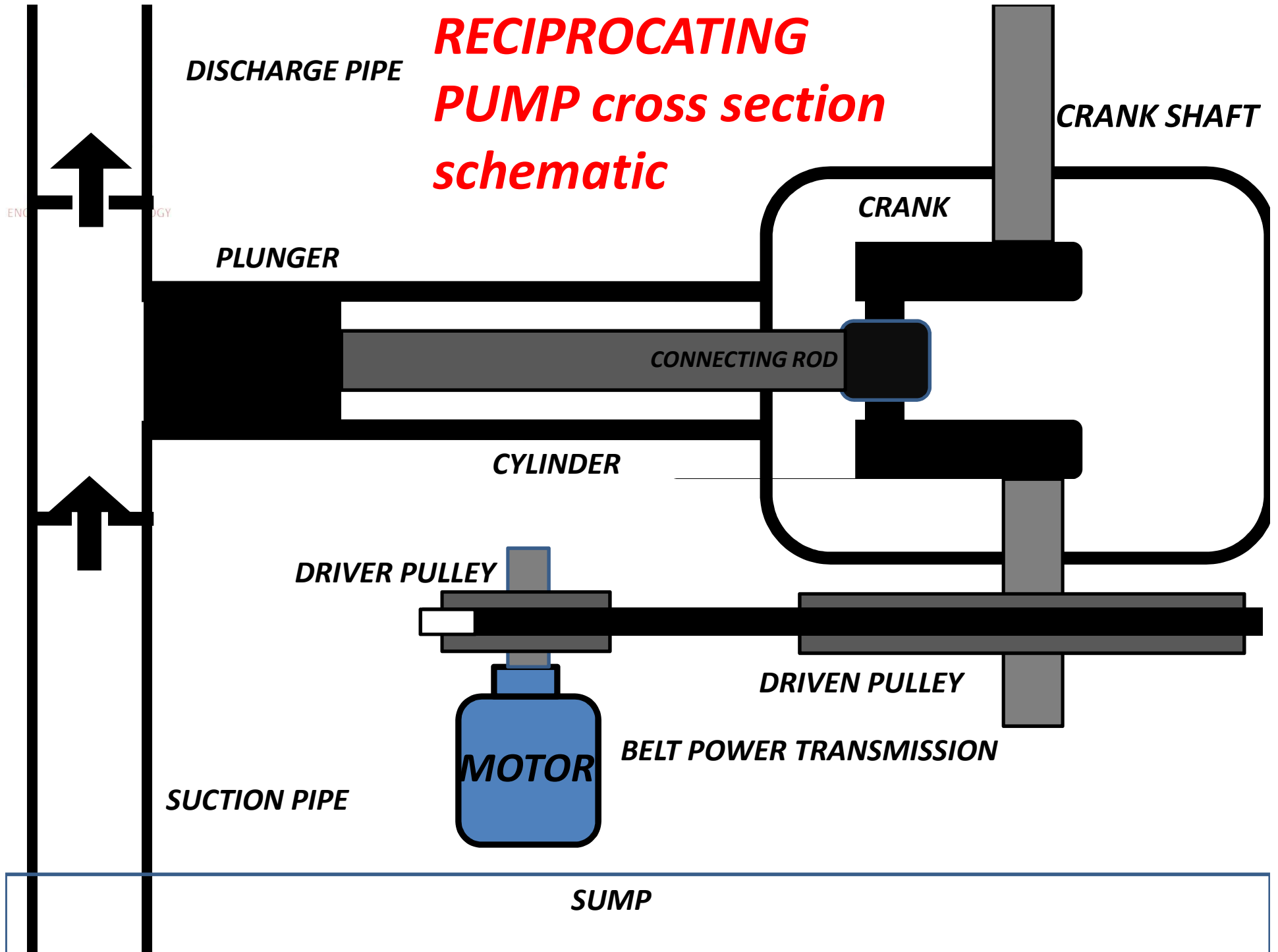

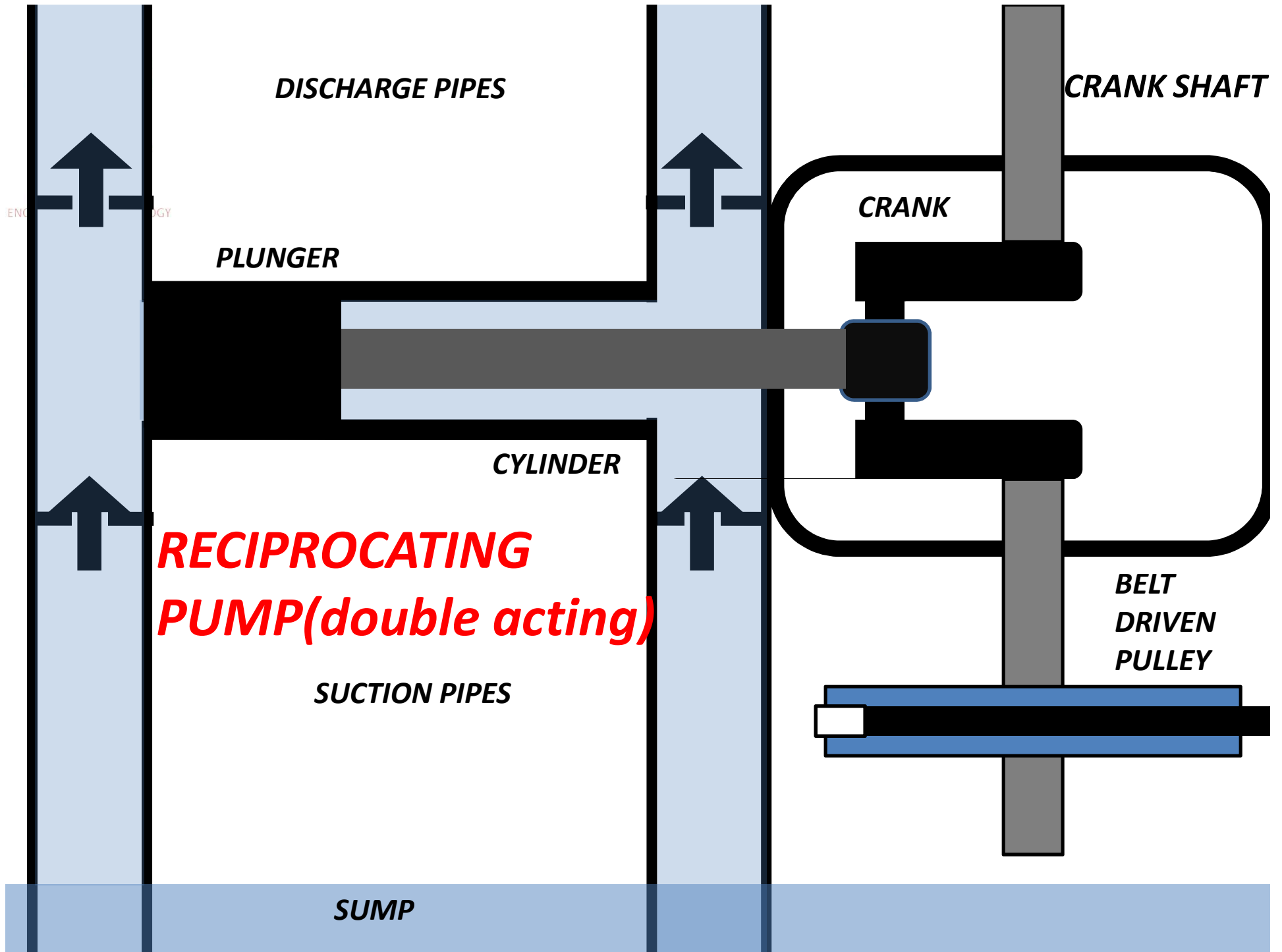

*DISCHARGE PIPES*

*CRANK SHAFT*

*PLUNGER*

*CRANK*

*CYLINDER*

***RECIPROCATING  
PUMP (double acting)***

*BELT  
DRIVEN  
PULLEY*

*SUCTION PIPES*

*SUMP*

*ENERGY*



# **RECIPROCATING PUMP**

**AIR VESSELS AT SUCTION  
AND DISCHARGE SIDE**

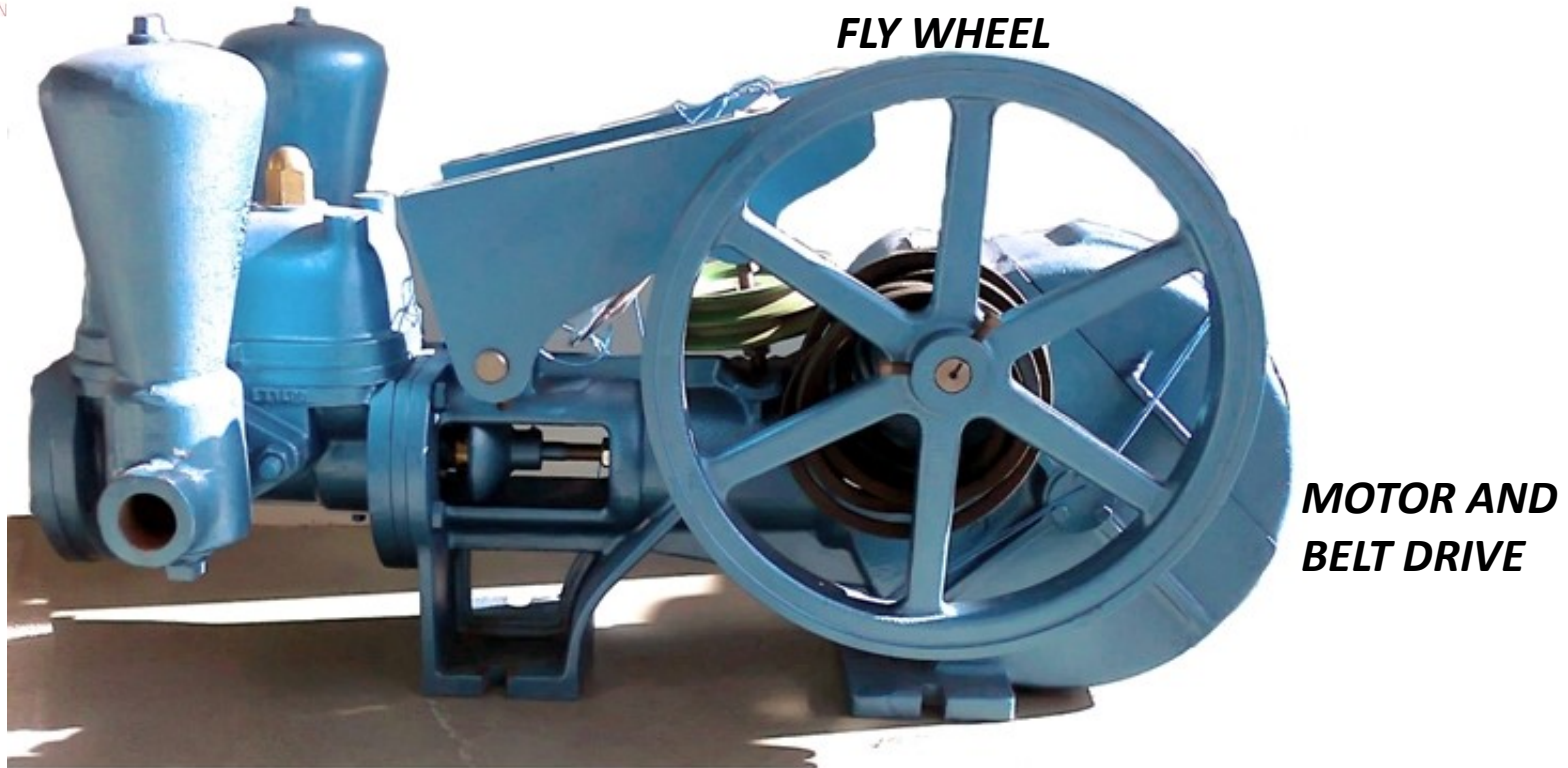

**FLY WHEEL**

**MOTOR AND  
BELT DRIVE**

**AIR VESSELS ARE PROVIDED TO OBTAIN CONTINUOUS FLOW.  
DURING DISCHARGE SOME WATER GETS INTO AIR VESSEL AND AIR IN THERE  
GET COMPRESSED.  
DURING SUCTION AIR INSIDE THIS VESSEL PUSHES THE WATER UNDER IT  
THROUGH DISCHARGE PIPE.  
THUS FLOW CAN BE OBTAINED EVEN DURING THE SUCTION**



# ***GEAR PUMP*** ***cross section*** ***schematic***

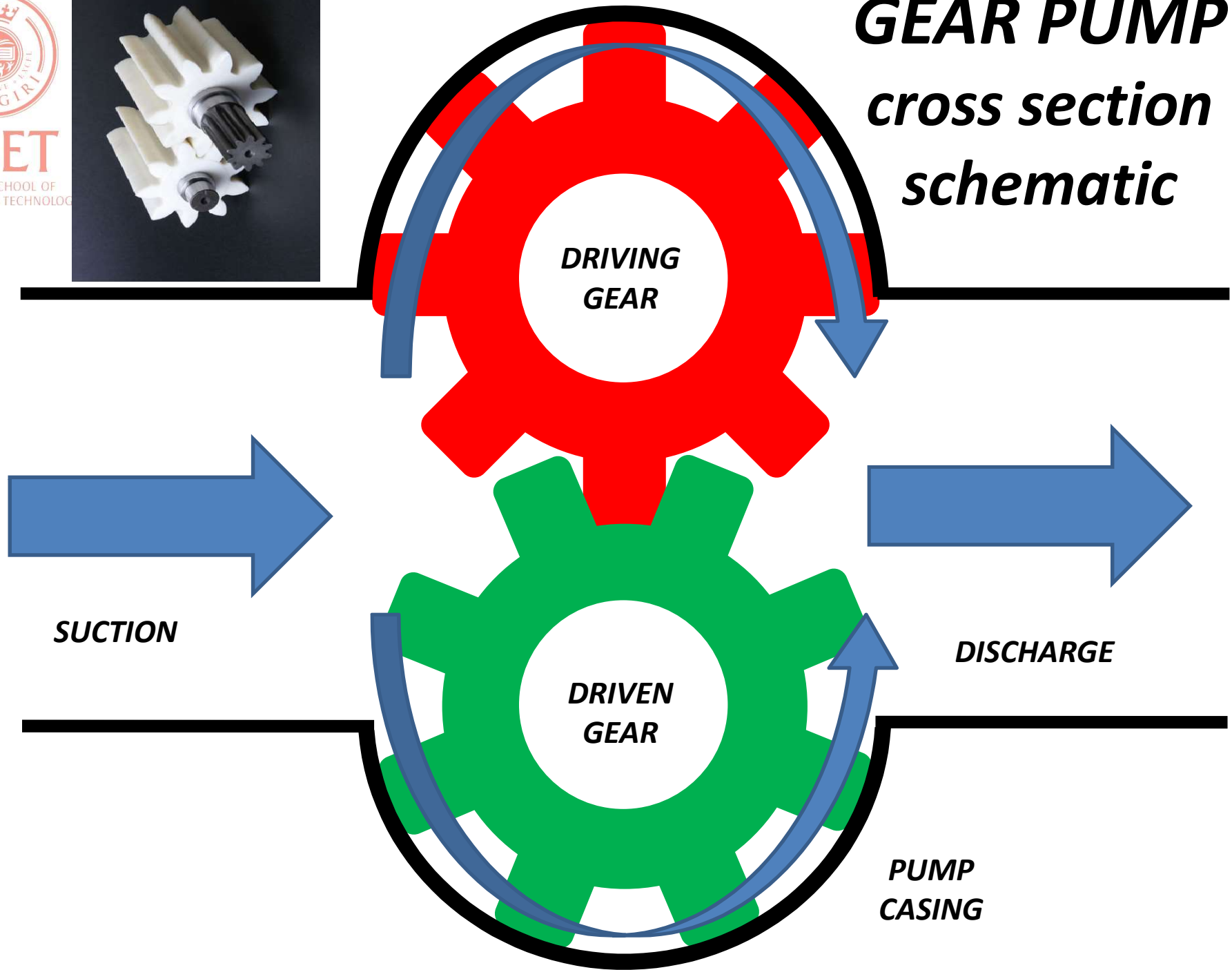



RSET

SCHOOL OF TECHNOLOGY

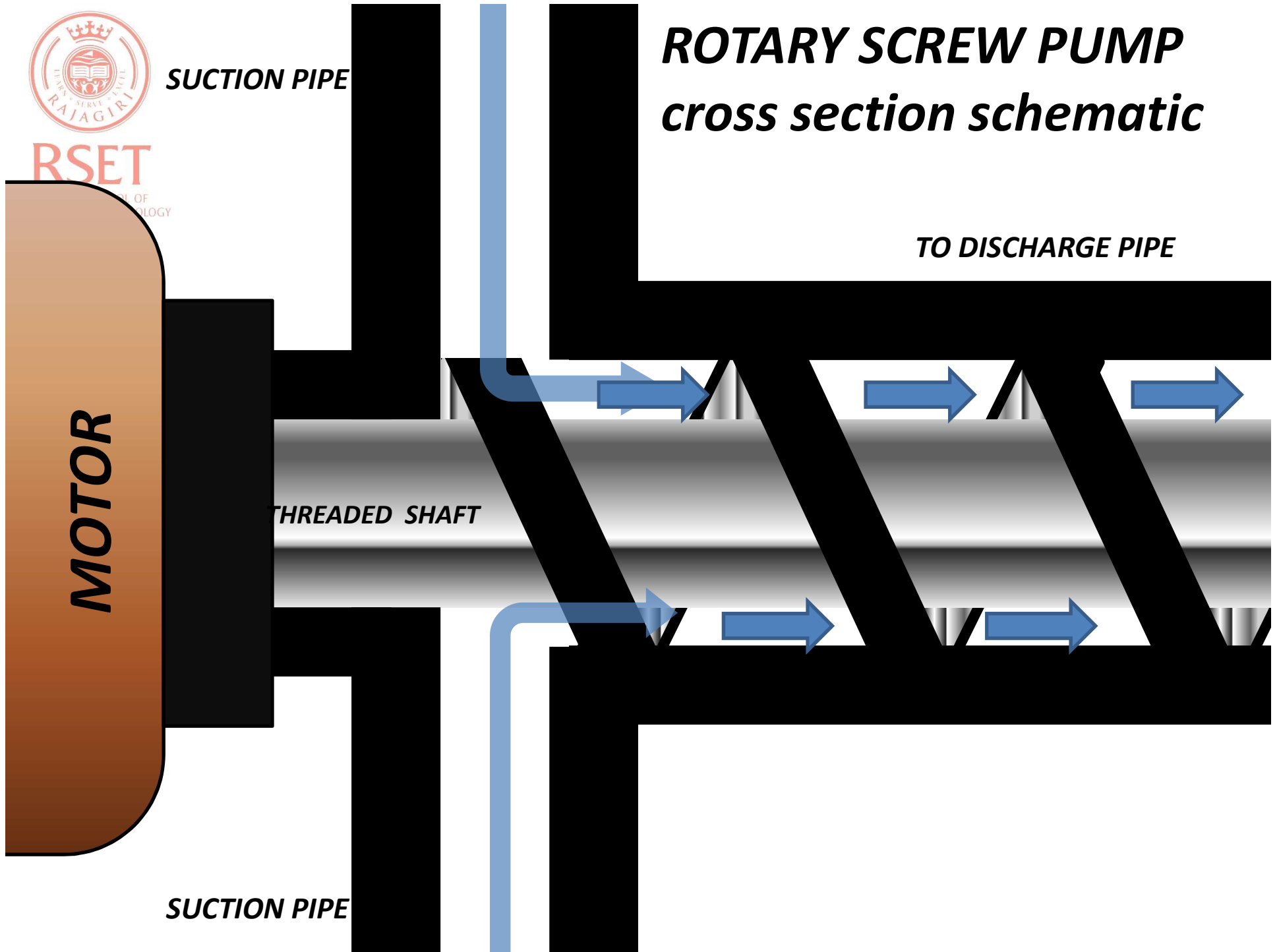



**RSET**

RAJAGIRI SCHOOL OF  
ENGINEERING & TECHNOLOGY

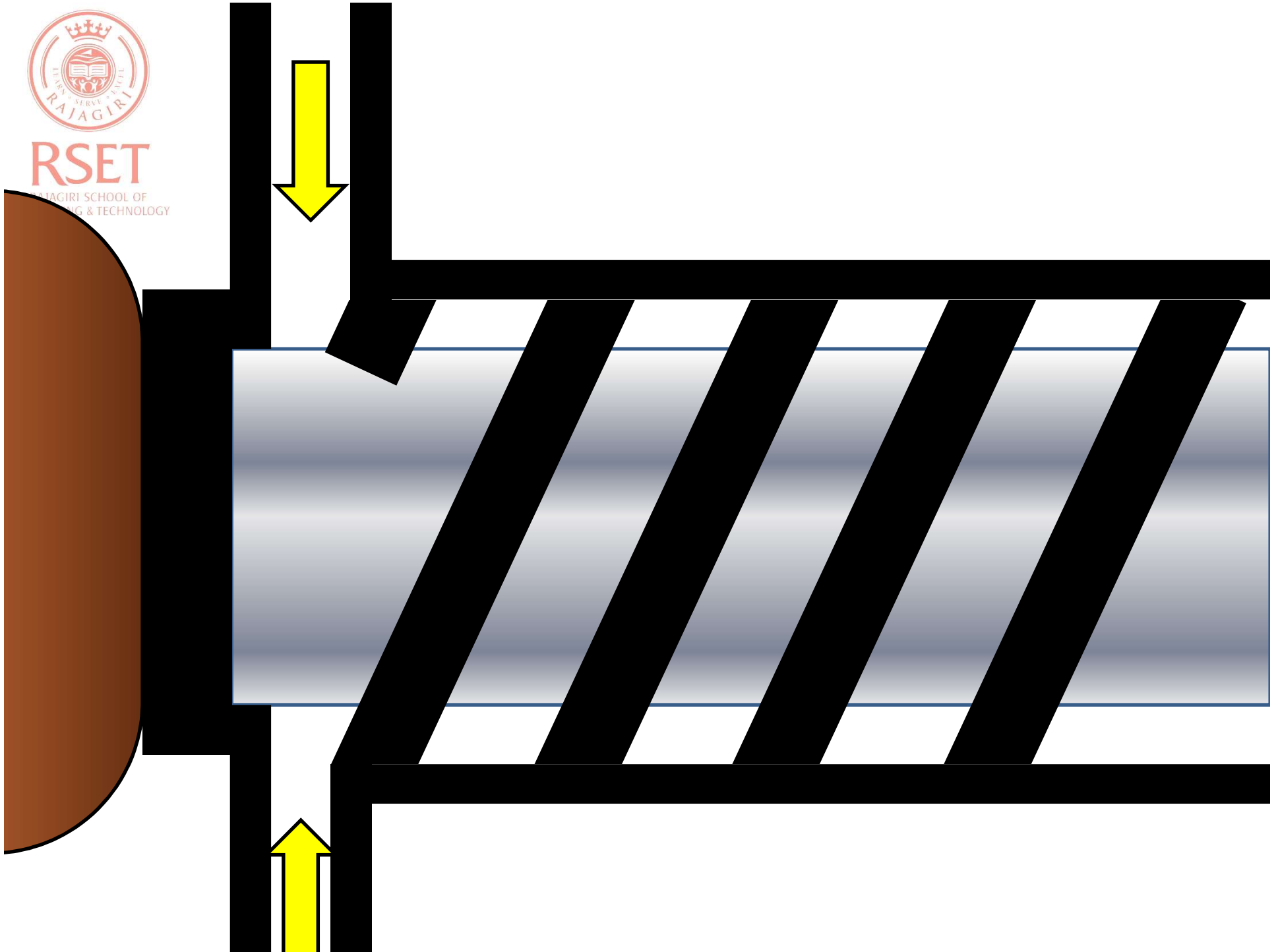

# **ROTARY VANE PUMP** *cross section schematic*

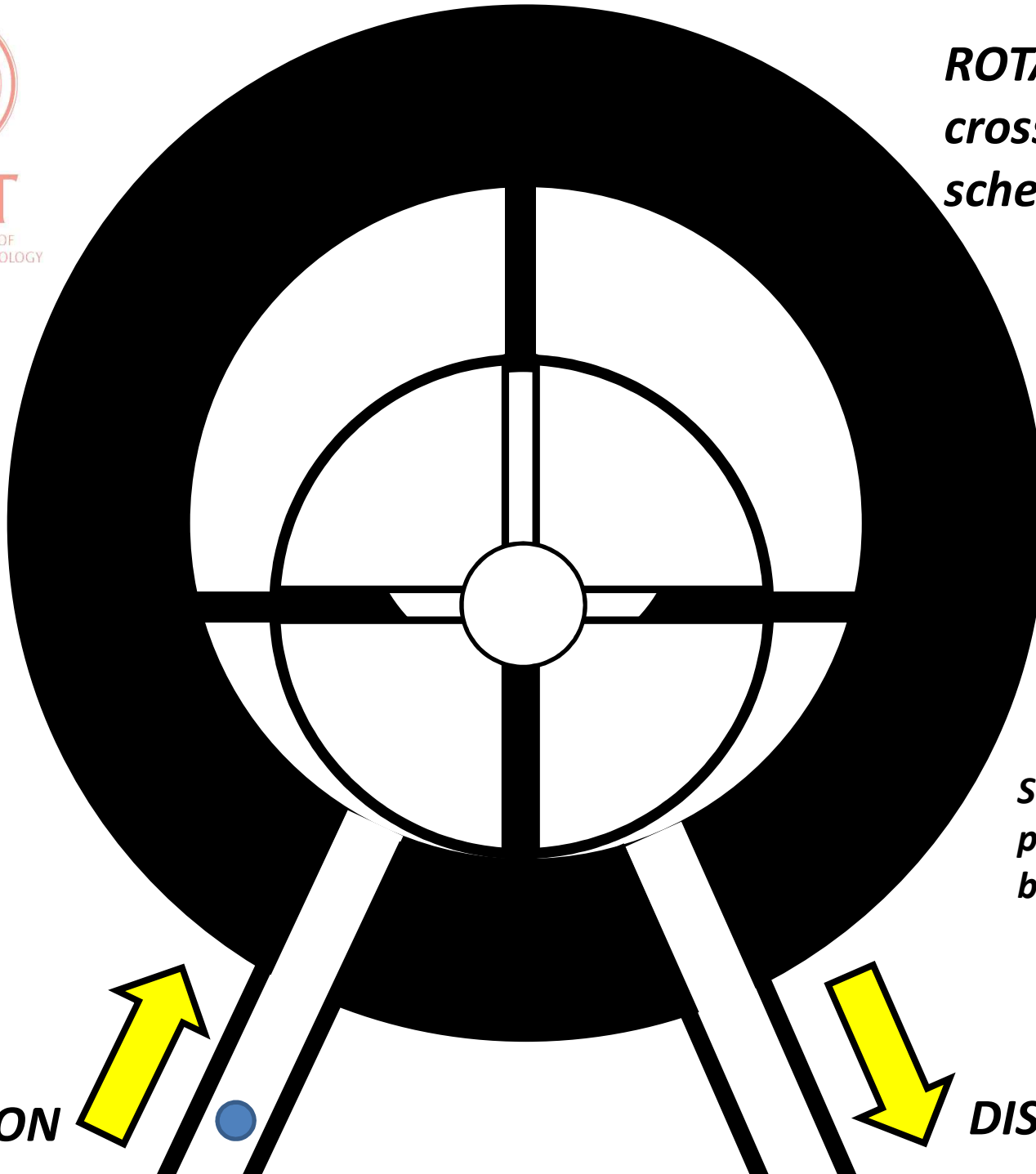

**CASING WITH  
ECCENTRIC ROTOR  
AND SLIDER(vanes)  
ASSEMBLY**

*SLIDERS (vanes) are  
pushed on to casing  
by means of springs*

**SUCTION**

**DISCHARGE**

# **CENTRIFUGAL PUMP PARTS**



**SCROLL CASING**

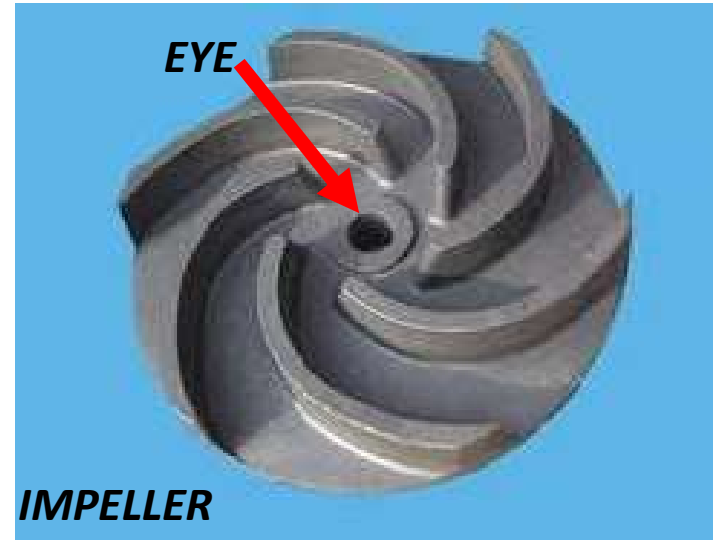

**IMPELLER**

**IMPELLER and  
SCROLL CASING  
ASSEMBLY**



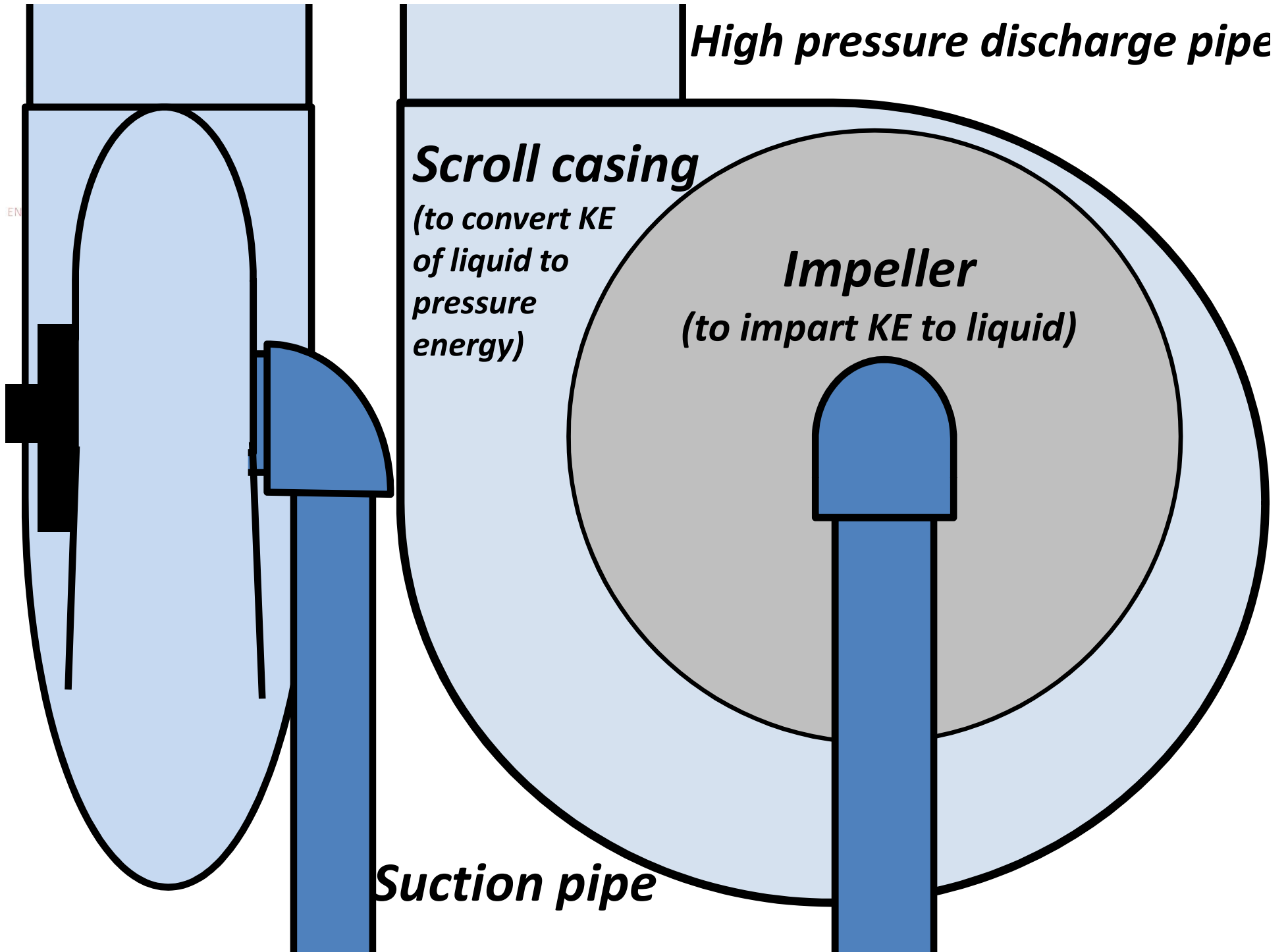

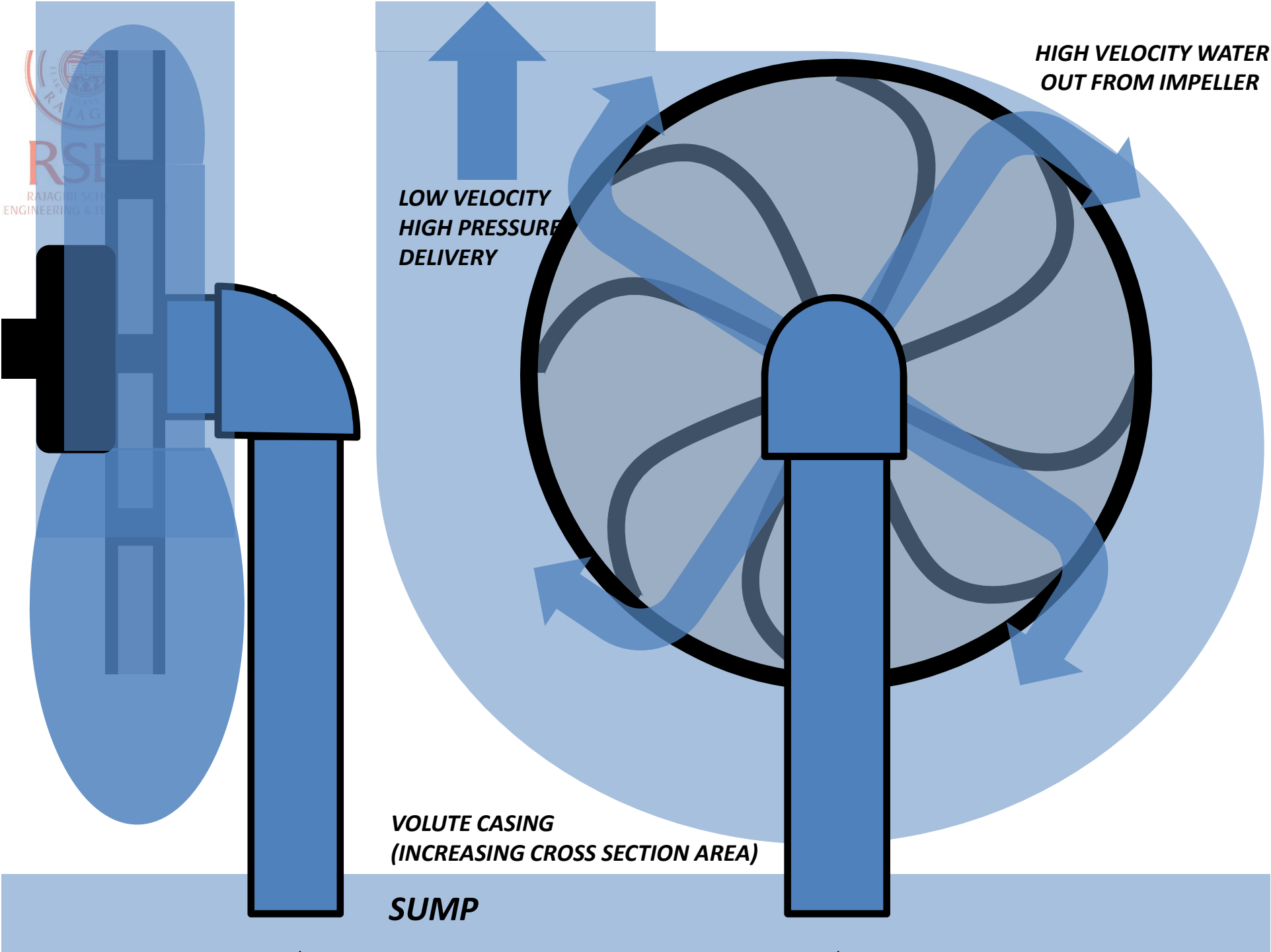

**LOW VELOCITY  
HIGH PRESSURE  
DELIVERY**

**HIGH VELOCITY WATER  
OUT FROM IMPELLER**

**VOLUTE CASING  
(INCREASING CROSS SECTION AREA)**

**SUMP**





# NPSH(NET POSITIVE SUCTION HEAD)

**RSET**  
RAJAGIRI SCHOOL  
ENGINEERING & TECHNOLOGY

- *when pressure of a liquid decreases its boiling point decreases and it starts to boil even at room temperature.*
- *In centrifugal pump suction pressure(below atmospheric pressure or -ve pressure) is created at the eye of the rotating impeller.*
- *when this pressure falls below a particular level liquid starts boiling to form vapor bubbles, when this vapor bubbles reaches any high pressure side it collapses producing pressure waves. This phenomenon is called Cavitation.*

## CAVITATION PHENOMENON

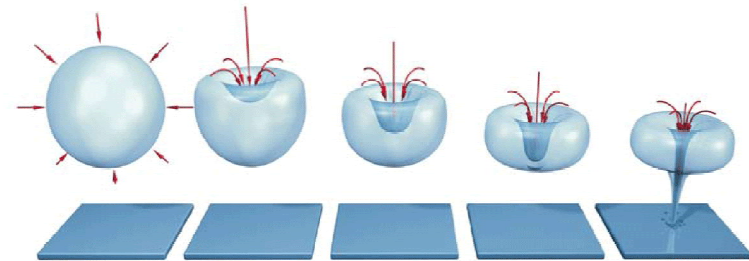

- *when this pressure waves hits impeller or casing they get eroded and decreases life of the pump.*
- *To avoid this suction pressure should be decreased.*
- *NPSH is the max possible suction pressure (in meters of liquid) to avoid Cavitations.*

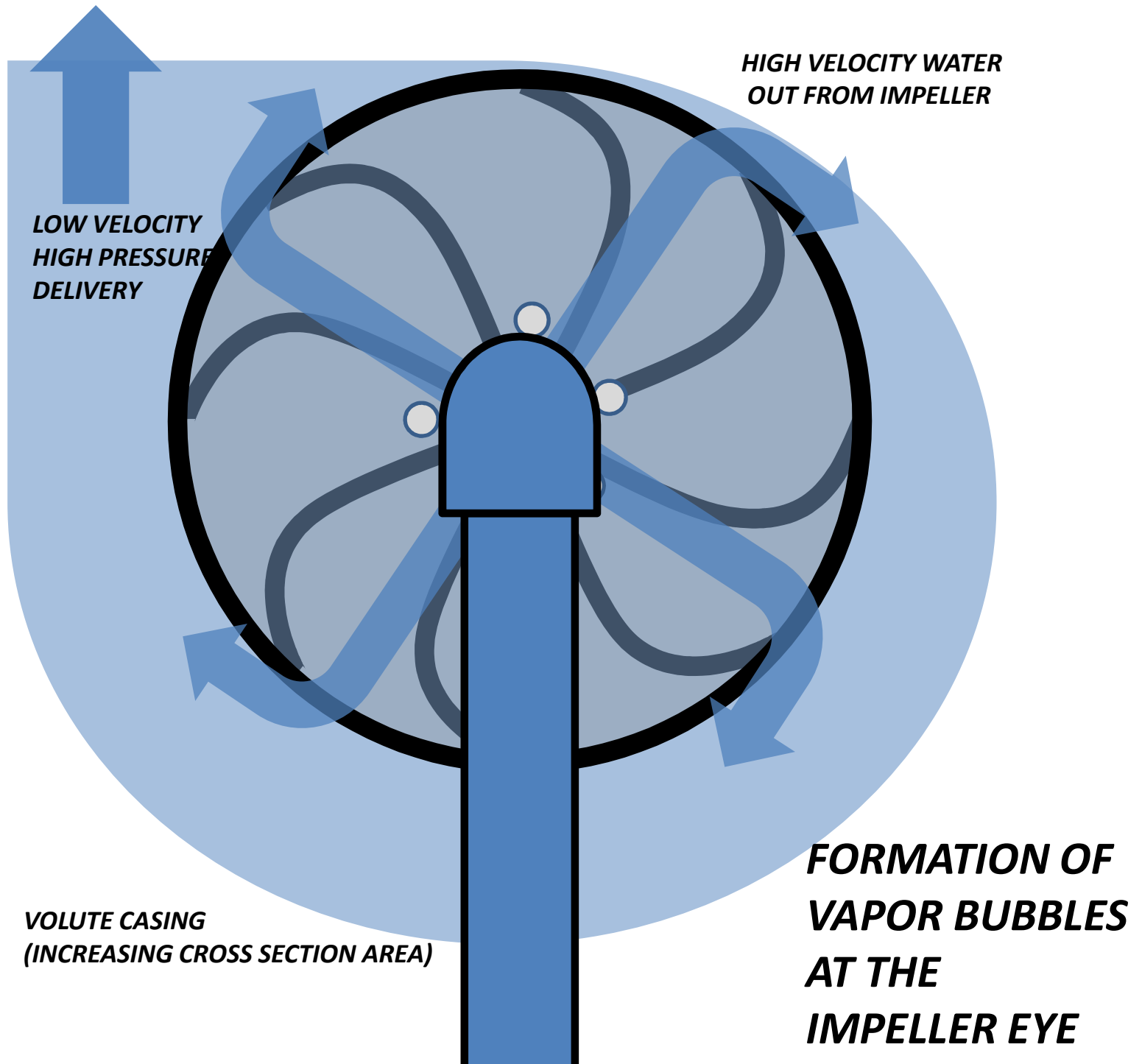

# ***COMPRESSORS***

***A DEVICE USED TO INCREASE THE  
PRESSURE AND FOR  
DESPLACEMENT OF A GAS***

***ROTARY  
COMPRESSORS***

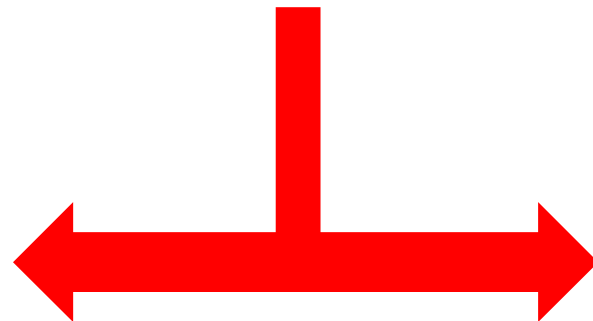

***ROTO-DYNAMIC  
COMPRESSORS***



# **ROTARY COMPRESSORS**

- *E.g. reciprocating compressors, screw compressors, vane compressors etc*
- *Positive displacement type*
- *Are usually used for high pressure low discharge applications*
- *Many machine components and complex construction*
- *Runs at low speed.*
- *Cannot be directly connected to motor without any power transmission medium (gears, belts etc)*
- *Large space is required for installation compared to Roto-dynamic compressors*
- *Fluid flow is intermittent or pulsating*
- *Fly wheel is necessary for reciprocating compressors because of uneven torque (less torque during suction and high torque during compression)*



# APPLICATIONS OF ROTARY COMPRESSORS

- **AUTOMATED CONTROL SYSTEMS-**

*To remove dust particles from sophisticated electronic instruments*

- **PNEUMATIC MACHINERIES AND MANUFACTURING INDUSTRIES –**

*Casting, sand blasting etc*

- **IN STEEL MANUFACTURING-**

*For supplying air into the burners and for cooling down of rolled steels.*

- **CHEMICAL INDUSTRIES-**

*Ammonia synthesis, molding plastics, storage and transport of gases*

- **FOOD PROCESSING-**

*Agitation, pressurized food transport, cooling and packing*

- **MACHINERIES-**

*Pneumatic robotic actuators, power screws etc,*

- **MINES-**

*Used for pneumatic machines and for supplying oxygen*

*e.g. Reciprocating compressors(low speed), screw compressors etc*



**RSET**

RAJAGIRI SCHOOL OF  
ENGINEERING & TECHNOLOGY

# **ROTODYNAMIC COMPRESSORS**

*E.g. centrifugal compressors, axial compressors*

- *Non- positive displacement type.*
- *Are usually used for low pressure high discharge applications.*
- *Less machine components and simple in construction.*
- *Gas flow is continuous.*
- *Requires less space for installation compared to rotary compressors.*
- *discharge pressure can be increased by multi stage compression without much wastage of space.*



**RSET**

RAJAGIRI SCHOOL OF  
ENGINEERING & TECHNOLOGY

# **APPLICATIONS OF ROTODYNAMIC COMPRESSORS**

- *Petroleum and chemical industries- boosting pressures of gases for various applications like promoting catalytic reactions, thermal decompositions, separation of gases etc.*
- *Turbo-charging and super-charging in automobile engines.*
- *Directly connected to turbines to draw power in gas turbine engines and jet engines.*

# RECIPROCATING COMPRESSOR SCHEMATIC

**HIGH PRESSURE  
EXHAUST SIDE**

**PISTON AND  
CYLINDER**

**CONNECTING ROD**

**CRANK CASE**

**CRANK**

**LOW PRESSURE  
INLET SIDE**

**MOTOR**

**BELT DRIVE  
POWER  
TRANSMISSION**

**DRIVEN PULLEY**

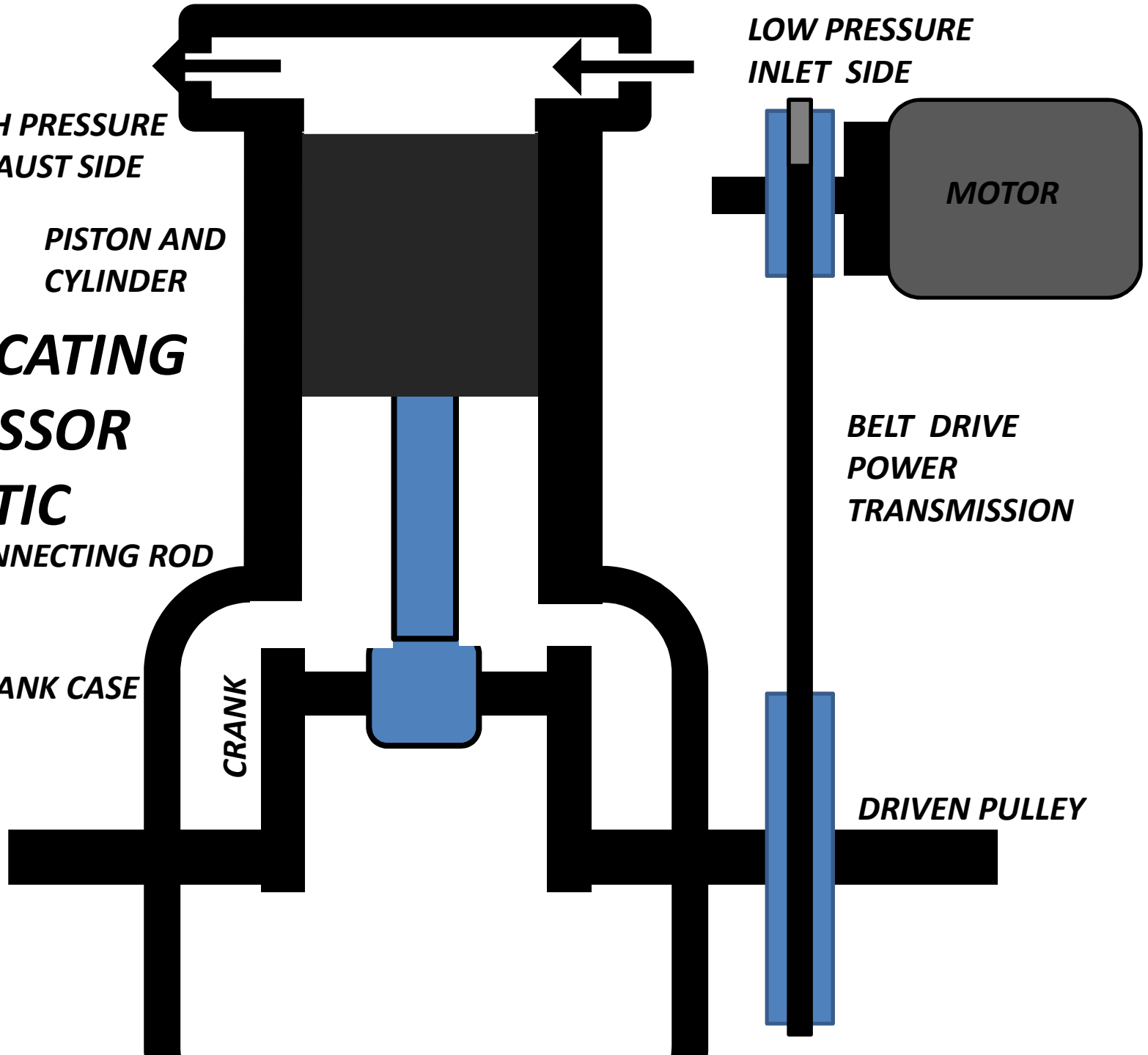





**RSET**  
RAJAGIRI SCHOOL OF  
ENGINEERING & TECHNOLOGY

# RECIPROCATING COMPRESSOR



**FILTER AND LOW  
PRESSURE INLET**



**PROTECTIVE GUARD**

**HIGH PRESSURE  
OUTLET**

**MOTOR**

**SUPPORTING FRAME**



**DRIVING PULLEY  
+ FLY WHEEL  
+ COOLING FAN**

**CRANK CASE**

# **ROTARY VANE COMPRESSOR SCHEMATIC**

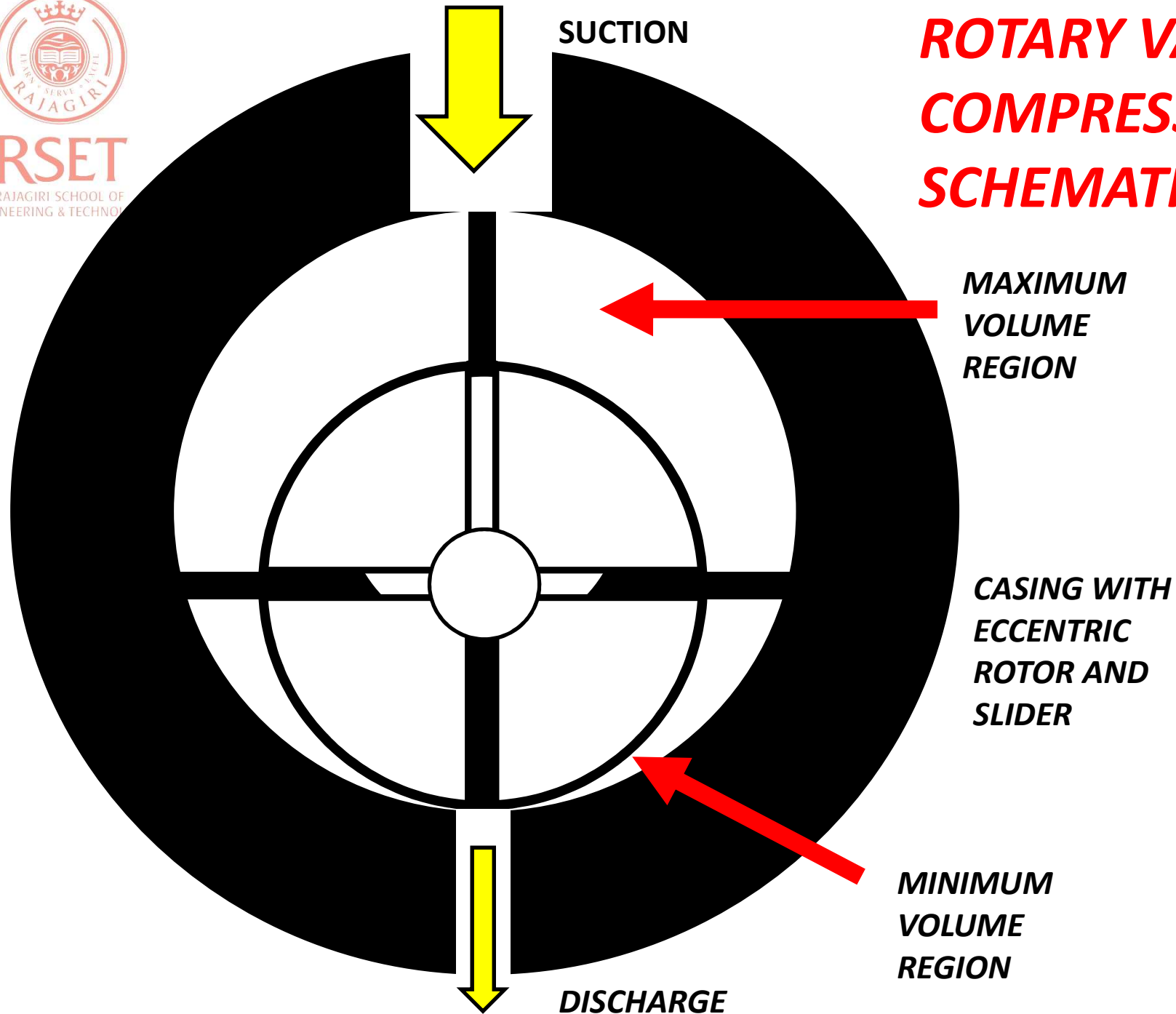



**RSET**

RAJAGIRI SCHOOL OF  
ENGINEERING & TECHNOLOGY

# ***CENTRIFUGAL COMPRESSOR PARTS***

***IMPELLER SCROLL  
CASING ASSEMBLY***



***IMPELLER***

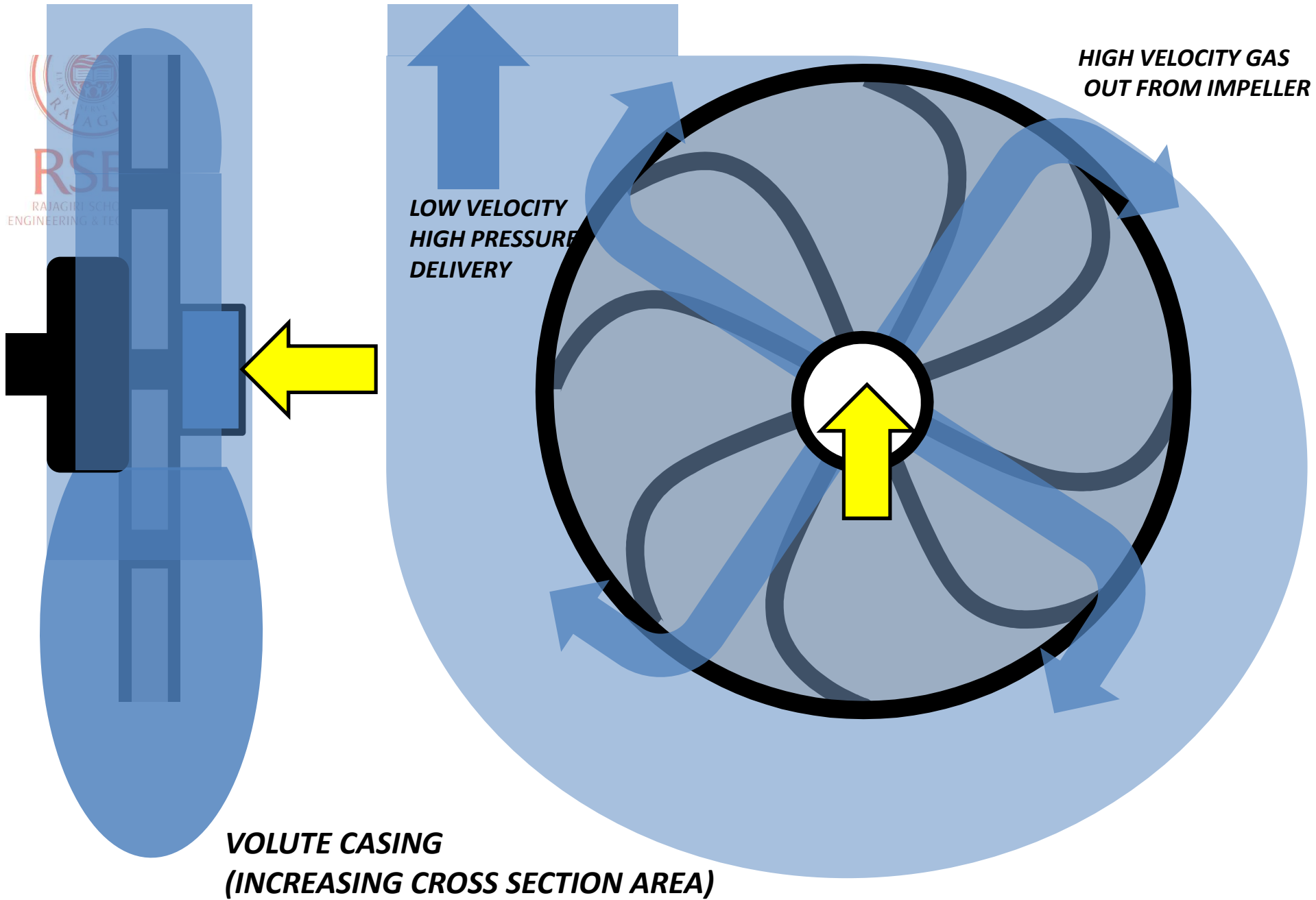

  
**RSE**  
RAJAGIRI SCHOOL  
OF ENGINEERING & TECHNOLOGY

# ***CENTRIFUGAL COMPRESSOR SCHEMATIC***

# ***FANS AND BLOWERS***

***Devices used to displace or convey gases from one place to another, against some obstructions or frictions.***

# ***TYPES OF FANS***



***PROPELLER TYPE***



***CENTRIFUGAL TYPE***



***TUBE AXIAL TYPE***

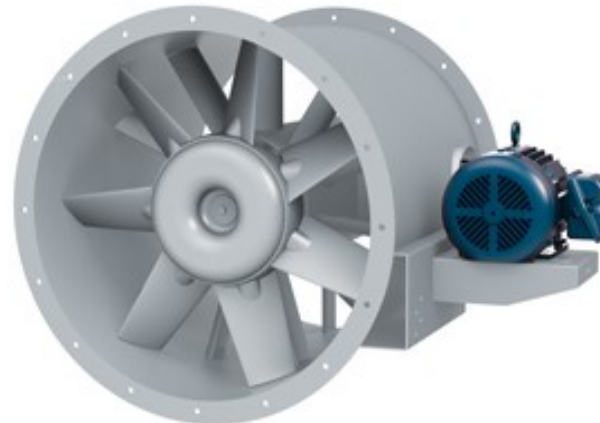

***VANE AXIAL TYPE***



**RSET**

RAJAGIRI SCHOOL OF  
ENGINEERING & TECHNOLOGY

# **AIR MOTORS**

- *Air motors are used where electric motors cannot be used. Like in mines and oil rigs where electric sparks should be avoided.*
- *Used in Portable tools like pneumatic nut tighter, pneumatic screw drivers where usage of electric motors can be heavy and bulky.*
- *Air motors are supplied with high pressure air from high capacity storage tanks via high pressure tubes.*
- *The storage tanks are usually placed in remote areas (away from air motors) and are continuously filled with high pressure air by using any type of Rotary (positive displacement) compressors.*

*Main types of air motors are :-*

- *Turbine type*
- *Reciprocating piston type*
- *Rotary vane type*



***PNEUMATIC HAMMER***



***PNEUMATIC NUT RUNNER***

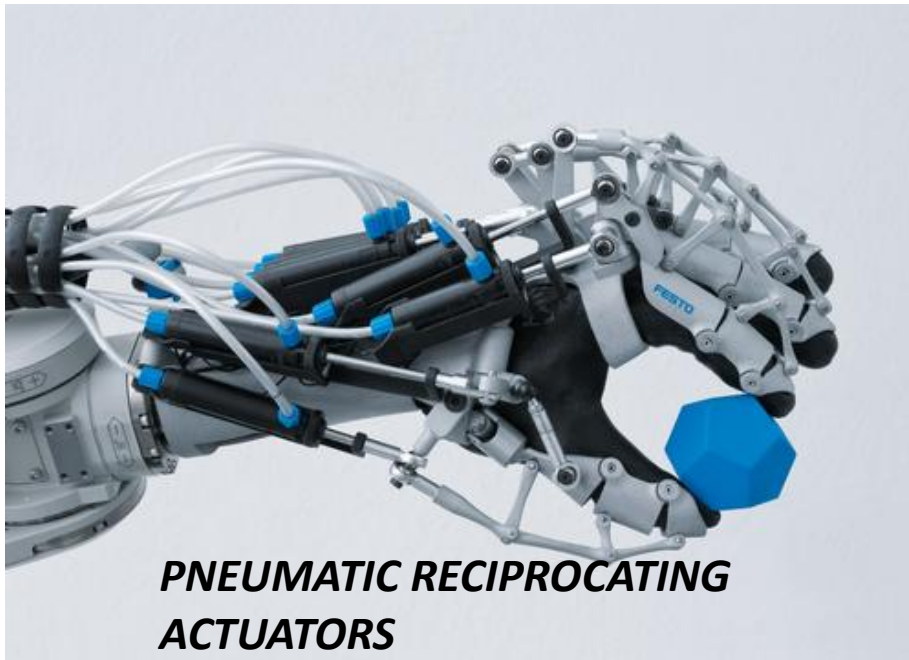

***PNEUMATIC RECIPROCATING  
ACTUATORS***





**RSET**  
RAJAGIRI SCHOOL OF  
ENGINEERING & TECHNOLOGY

**HIGH PRESSURE  
INLET FROM  
STORAGE TANK**



**LOW PRESSURE  
EXHAUST SIDE**

**CONSTANT  
LOW TORQUE HIGH SPEED  
POWER**

**PISTON AND  
CYLINDER**

**DRIVEN PULLEY**

# **RECIPROCATING AIR MOTOR SCHEMATIC**

**BELT DRIVE  
POWER  
TRANSMISSION**

**CONNECTING ROD**

**CRANK CASE**

**CRANK**

**VARIABLE  
HIGH TORQUE LOW SPEED  
POWER**

# ROTARY VANE TYPE AIR MOTOR SCHEMATIC

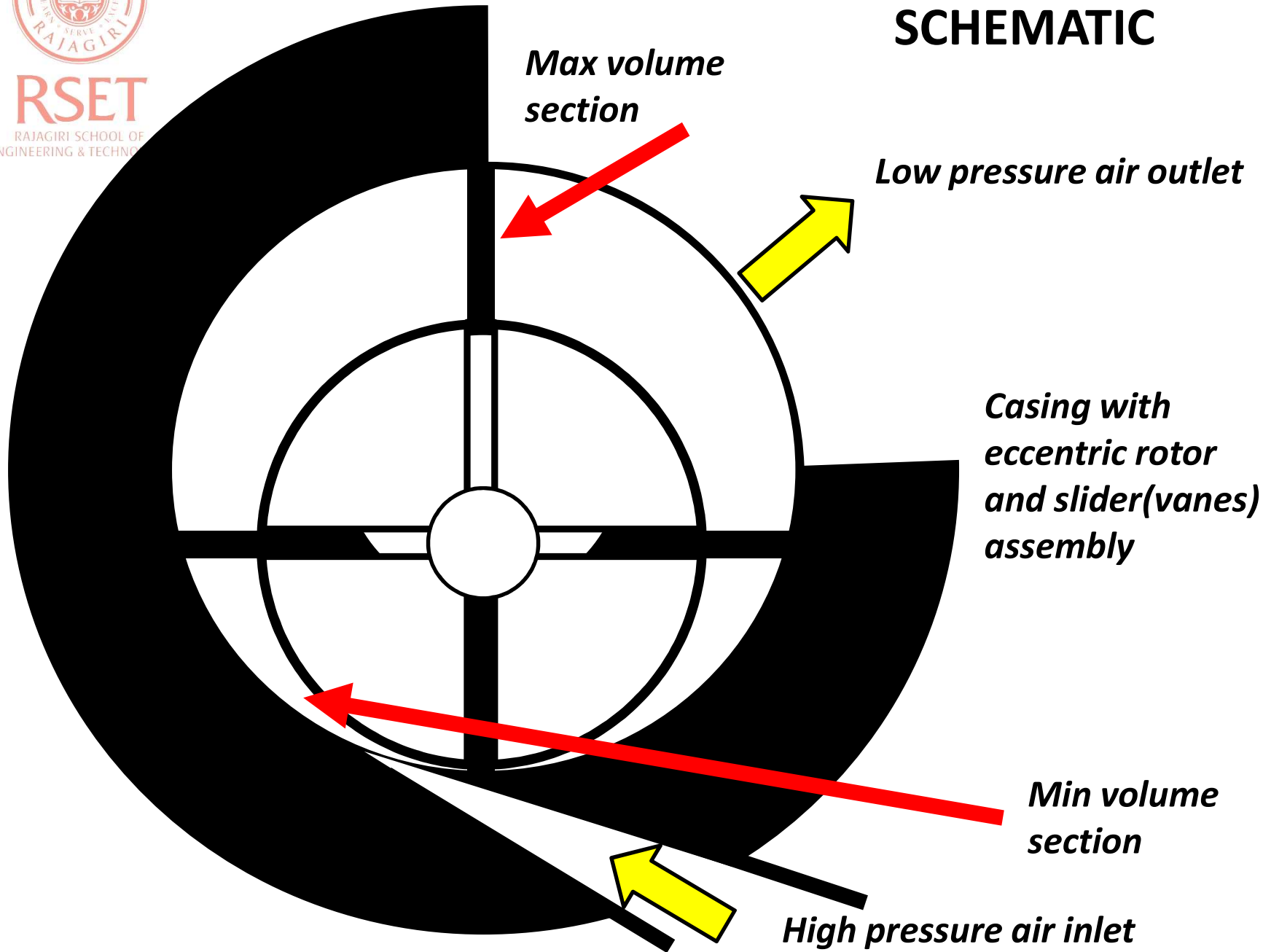

# ROTARY VANE AIR MOTOR

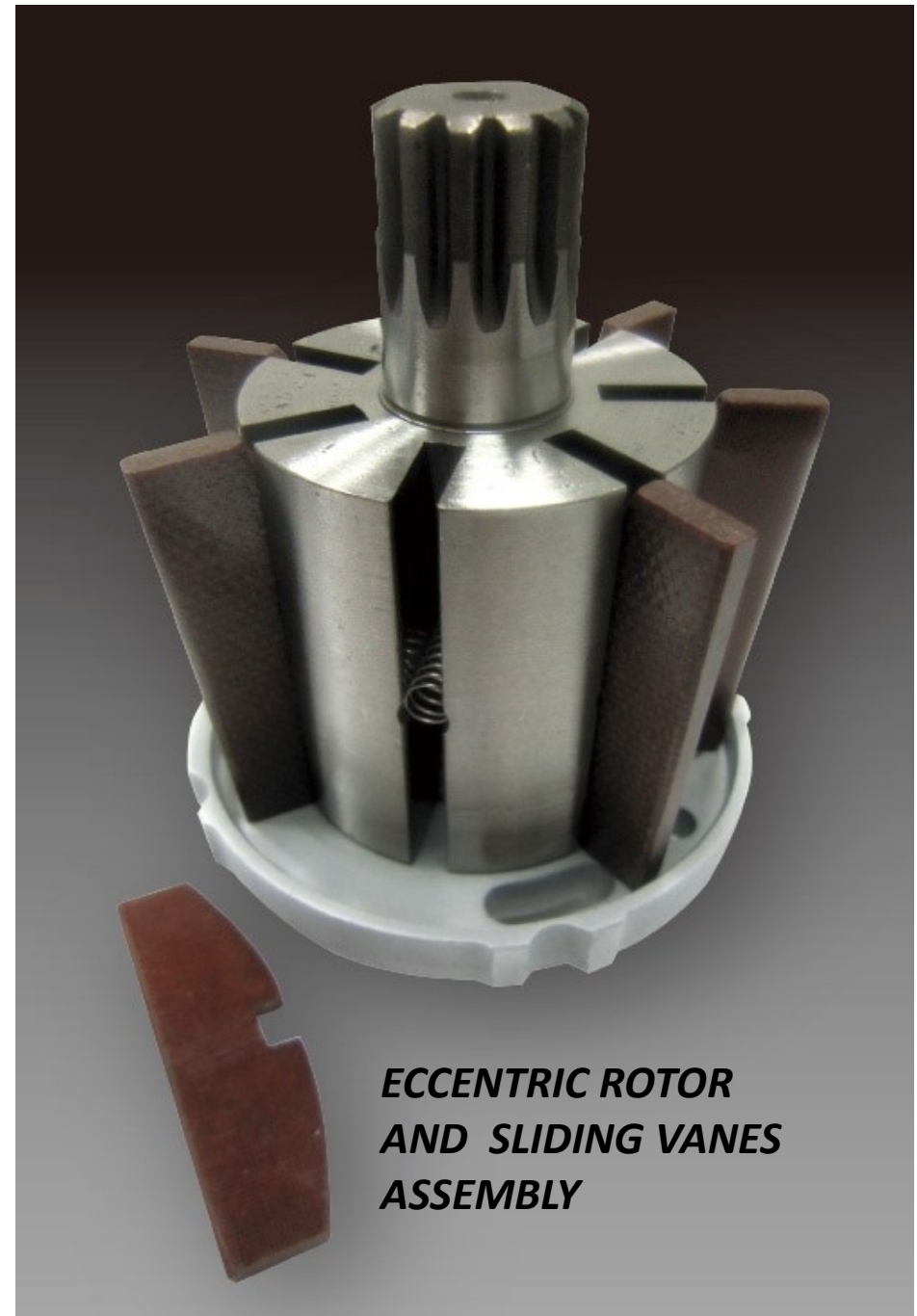
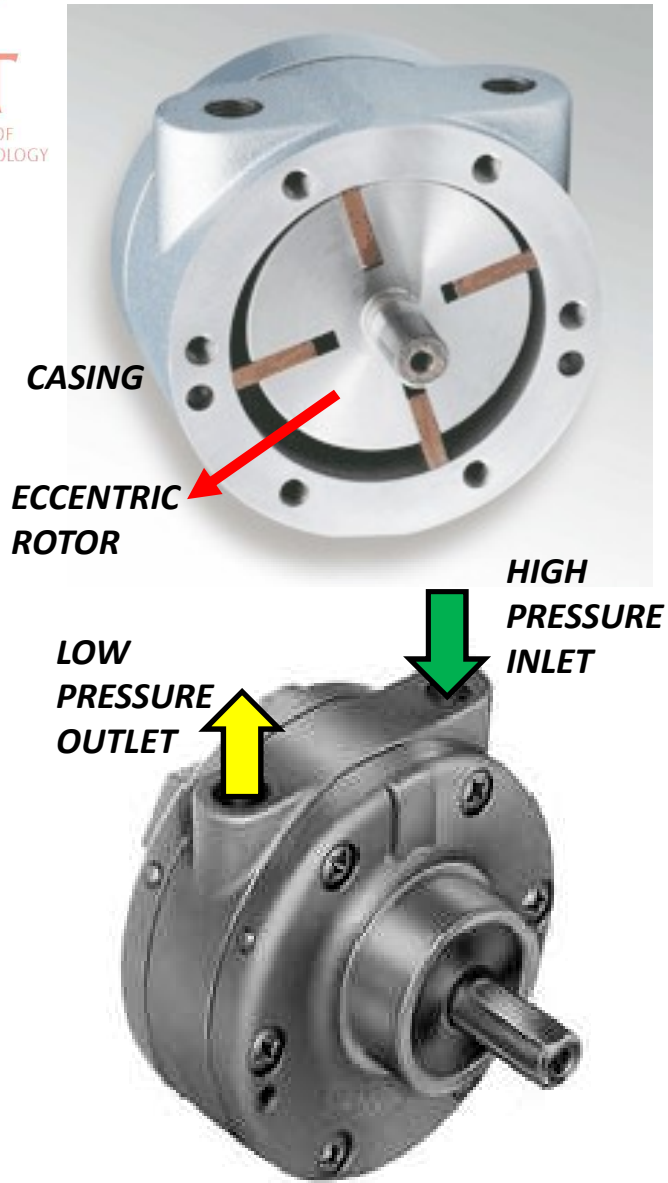

# ***TURBINE TYPE AIR MOTOR***

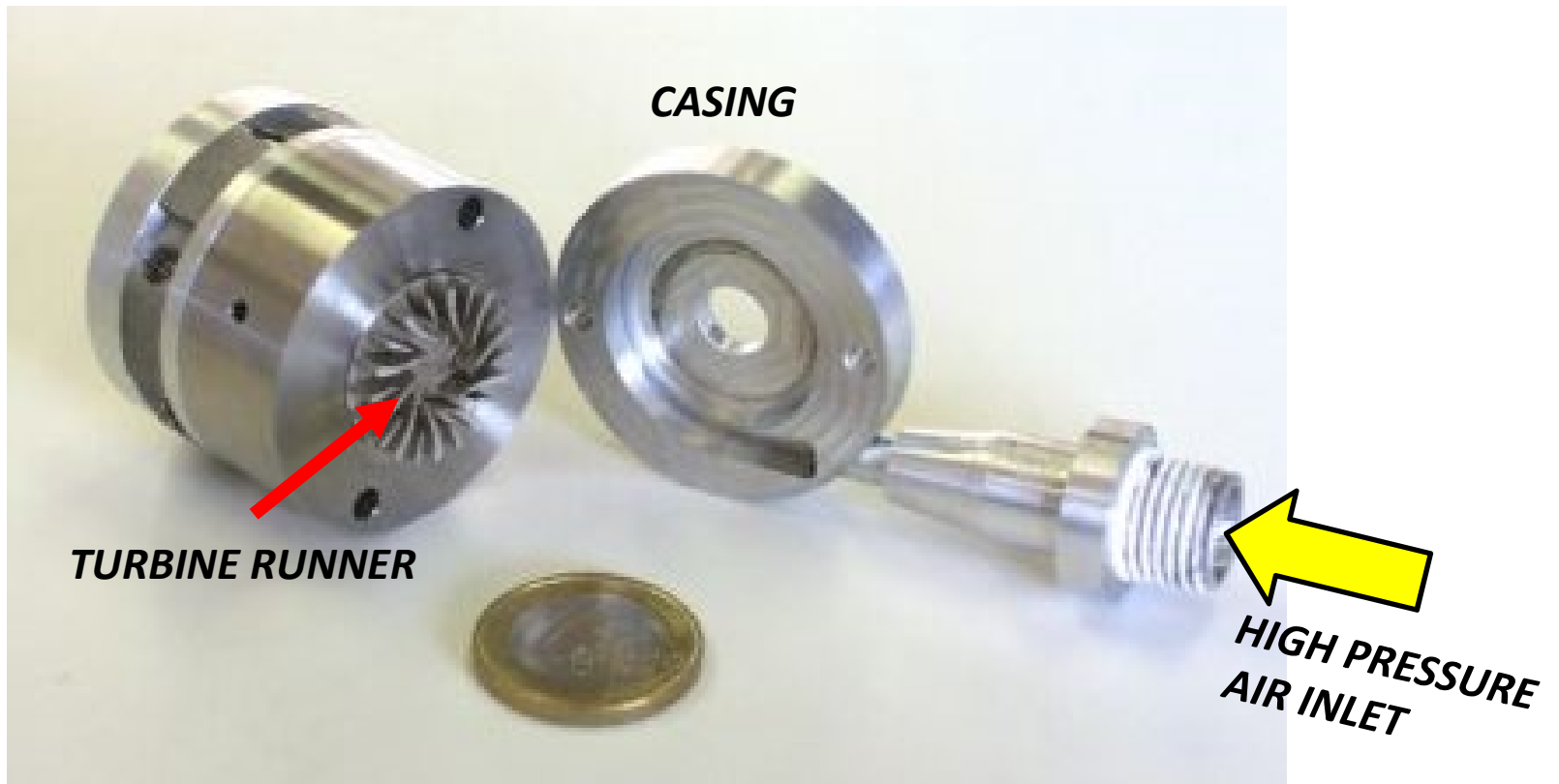



**RSET**  
RAJAGIRI SCHOOL OF  
ENGINEERING & TECHNOLOGY

## ***MODULE III***

# ***REFRIGERATION AND AIR CONDITIONING***

### ***REFERENCES:***

***Refrigeration And Air Conditioning, by Stoecker and Jones***  
***NPTEL lecture notes, IIT Kharagpur***



**RSET**

RAJAGIRI SCHOOL OF  
ENGINEERING & TECHNOLOGY

# **REFRIGERATION AND AIR CONDITIONING**

**REFRIGERATION** is the process of taking away heat from a medium continuously thereby maintaining a temperature below that of the surrounding.

- Preserving perishable products like food, blood, medicines, chemicals etc at low temperature
- Ice making.
- Liquefaction of gases.

**REFRIGERANTS**- Working fluid used in the refrigeration systems .

- These fluid usually absorbs heat from a medium by evaporation and rejects heat to surrounding by condensation.

**AIR CONDITIONING** refers to the treatment of air by controlling its temperature, moisture content, cleanliness, odor and circulation as required by the end user

- For human comfort e.g. window AC, Split AC, centralized AC unit
- For preservation e.g. organic tissues and embryos in lab
- For some processes e.g. egg hatcheries





**RSET**  
RAJAGIRI SCHOOL OF  
ENGINEERING & TECHNOLOGY

# ***REFRIGERATION***





**RSET**

RAJAGIRI SCHOOL OF  
ENGINEERING & TECHNOLOGY

# **REFRIGERATION SYSTEM TYPES**

- *Natural refrigeration system*
- ***Vapor compression refrigeration system***
- ***Vapor absorption refrigeration system***
- *Air refrigeration system*
- *Thermo-electric refrigeration system*
- *Magnetic refrigeration system*
- *Acoustic refrigeration system*
- *Vortex tube refrigeration system*



**RSET**  
RAJAGIRI SCHOOL OF  
ENGINEERING & TECHNOLOGY





**RSET**  
RAJAGIRI SCHOOL OF  
ENGINEERING & TECHNOLOGY

# **SIMPLE VAPOR COMPRESSION REFRIGERATION SYSTEM**

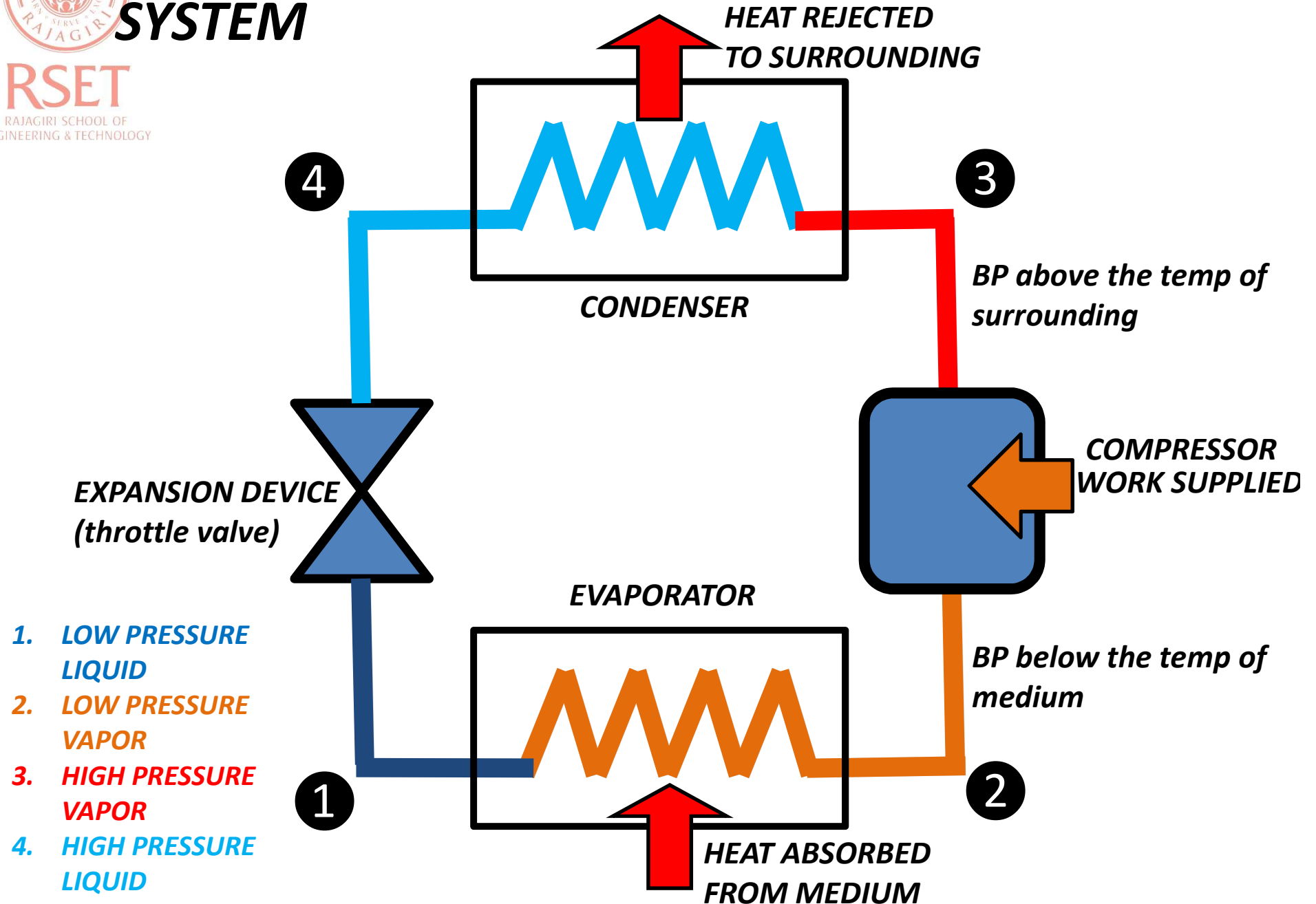

# PRESSURE - ENTHALPY DIAGRAM OF A REFRIGERANT FOR VAPOR COMPRESSION SYSTEM

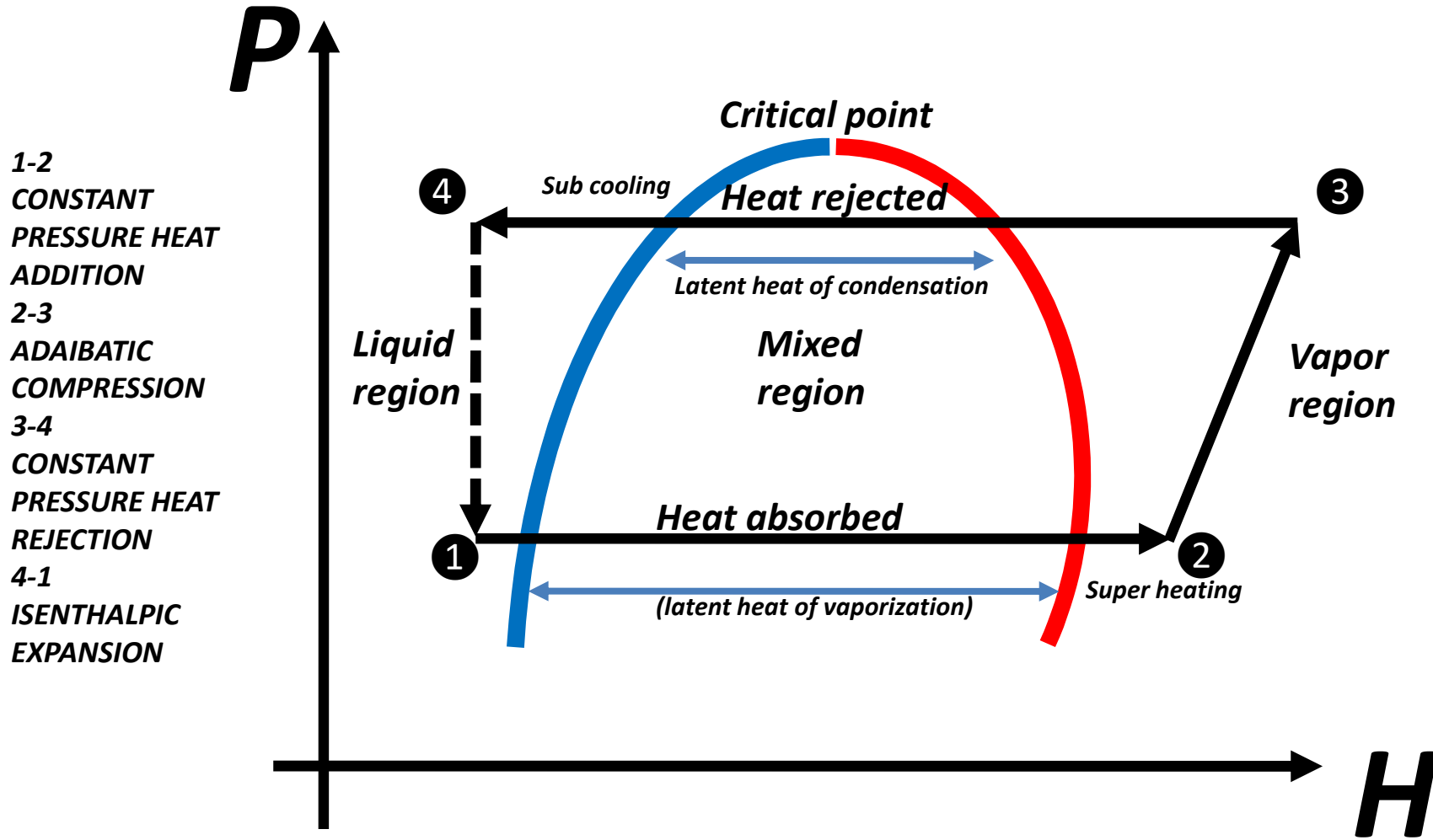

# MAJOR COMPONENTS OF A VAPOR COMPRESSION SYSTEM

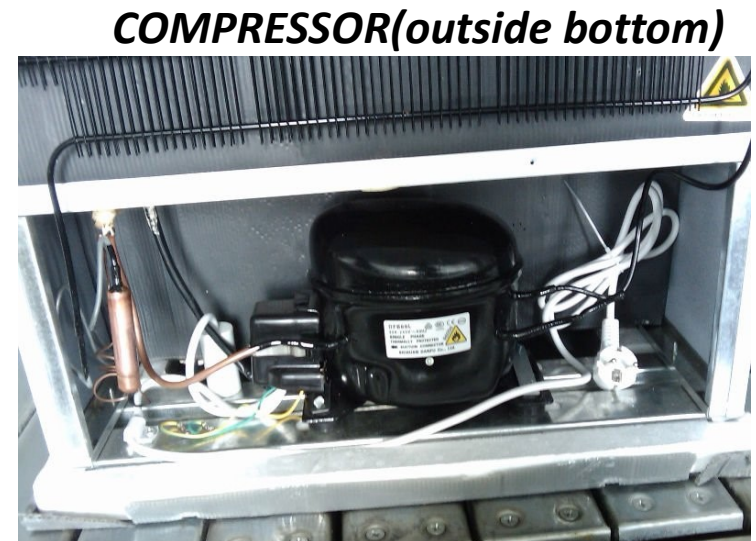
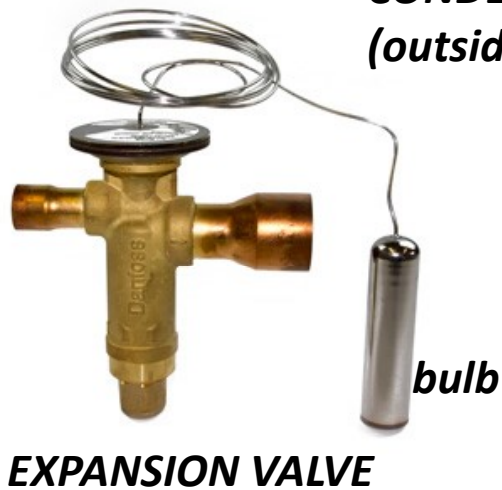

**Bulb (connected at exit of evaporator) in expansion valve (connected at inlet of evaporator) is used to detect change in heat load of refrigerator.**

**when heat load on the refrigerator decrease the bulb detects it and expansion valve will automatically decrease the flow rate of refrigerants.**



# **PROPERTIES OF AN IDEAL REFRIGERANT**

- *Refrigerants should be non toxic and it should not become toxic when mixed with other substances.*
- *Refrigerants should not be inflammable*
- *Refrigerants should have low boiling point at atmospheric pressure.*
- *Refrigerants should have low freezing point. It should not freeze at low evaporator temperatures.*
- *Evaporator and condenser pressure should be higher than atmospheric pressure. It avoids any air leak into the system.*
- *Refrigerants should be chemically stable. It should not decompose under operating conditions.*
- *Refrigerant should be non corrosive. It increases life of the system.*
- *Refrigerant should be miscible with lubricating oils and should not react with the lubricating oils. It*
- *Refrigerant should be odorless. It maintains the taste of food stuffs preserved.*



**RSET**  
RAJAGIRI  
ENGINEERING & TECHNOLOGY

# PROPERTIES OF AN IDEAL REFRIGERANT

- *Density of refrigerant should be high. It reduces the size of the compressor.*
- *Latent heat of evaporation should be high. It increases refrigeration effect with minimum amount of refrigerant.*
- *Latent heat of condensation should be high to carry out heat rejection process in the condenser isothermally. It reduces irreversibility.*
- *Critical point should be high.*
- *Specific heat of the refrigerant at liquid state should be low. It increases the degree of sub-cooling at the exit of the condenser and increases refrigeration effect.*
- *Specific heat of refrigerant at vapor state should be high. It decreases the degree of super- heating at the exit of the evaporator and decreases compressor work.*
- *Thermal conductivity of the refrigerants should be higher. It increases the heat transfer rate at the evaporator and condenser.*
- *Viscosity of the refrigerant should be low. It reduces frictional pressure drops and compressor work.*



**RSET**

RAJAGIRI SCHOOL OF  
ENGINEERING & TECHNOLOGY

# INFLUENCE OF SPECIFIC HEAT OF LIQUID AND VAPOR ON CAPACITY AND PERFORMANCE

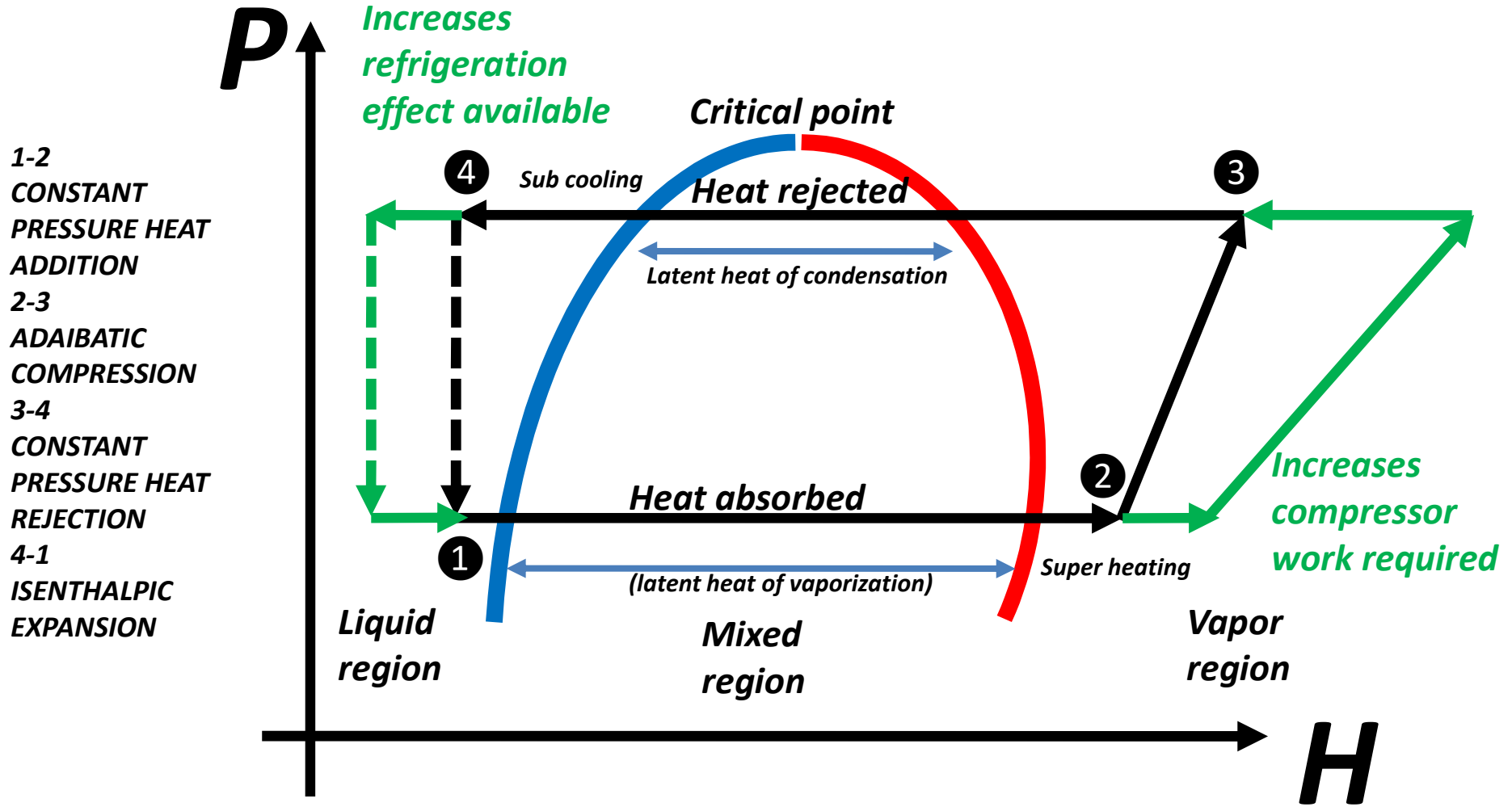



# ***SIMPLE VAPOR ABSORPTION REFRIGERATION SYSTEM***

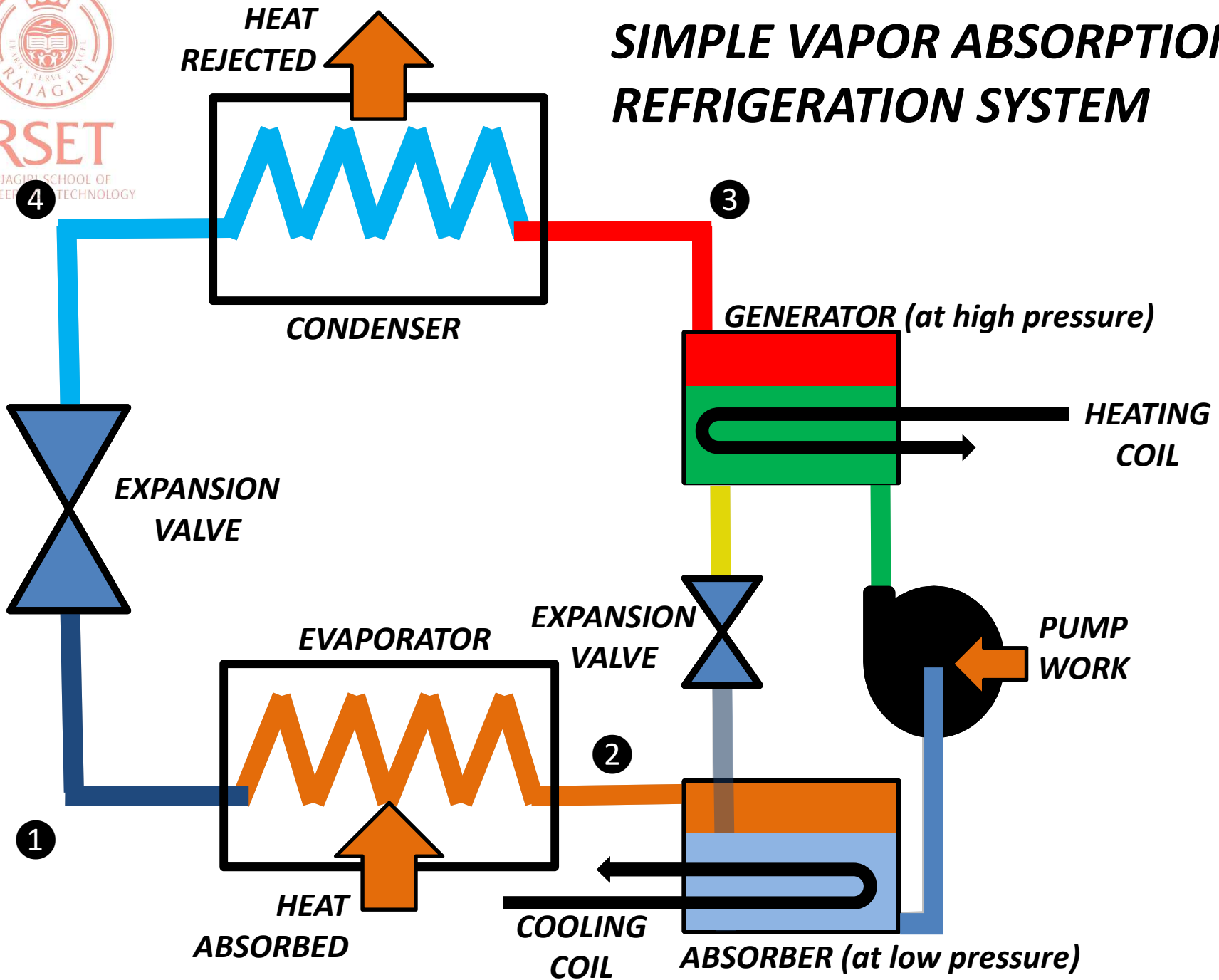



RSET

RAJAGIRI  
ENGINEERING COLLEGE

# **PARTS AND FUNCTIONS OF A SIMPLE VAPOR ABSORPTION SYSTEM**

- **ABSORBER** – *In this an absorbent liquid is present. It absorbs the refrigerant vapor (low pressure) at the exit of the evaporator.*
- **COOLING COIL**- *The absorption process is exothermic. So heat should be removed from the absorber to increase the absorption.*
- **PUMP**- *To increase the pressure of strong absorbent- refrigerant solution and pumps it to the generator.*
- **GENERATOR**- *In the generator, solution will be at high pressure.*
- **HEATING COIL** – *To split the refrigerant from absorbent in the generator by supplying heat(usually waste heat from industries). Thus high pressure refrigerant alone enters the condenser.*
- **EXPANSION VALVE**- *Remaining high pressure weak absorbent solution in the generator then flows back to absorber through an expansion valve at low pressure.*

# **DESIRABLE PROPERTIES OF REFRIGERANT-ABSORBENT MIXTURE**

- *Refrigerant should be highly soluble with the absorbent and heat of absorption should be low.*
- *Refrigerant should have very low BP than absorbent. Otherwise some absorbent will get boiled along with the refrigerants and gets into the cooling system, which reduces the refrigeration effect.*
- *Mixture should have high thermal conductivity, low freezing point, low viscosity, chemically stable, non-corrosive, inexpensive and easily available.*
- *Commonly used **REFRIGERANT - ABSORBENT** mixtures are,*
  1. **AMMONIA- WATER** (used in refrigeration)
  2. **WATER – LITHIUM BROMIDE** (used in air conditioning)



RSET

RAJAGIRI SCHOOL OF  
ENGINEERING AND TECHNOLOGY

# PERFORMANCE PARAMETER FOR A REFRIGERATOR

- **FOR VAPOR COMPRESSION SYSTEM**

$$\begin{aligned} \text{COP}_R &= \text{desired effect} / \text{spent effort} \\ &= \text{heat absorbed in evaporator} / \text{compressor work} \\ &= (h_2 - h_1) / (h_3 - h_2) \end{aligned}$$

- **FOR VAPOR ABSORPTION SYSTEM**

$$\begin{aligned} \text{COP}_R &= \text{desired effect} / \text{spent effort} \\ &= \text{heat absorbed in evaporator} / (\text{pump work} + \text{heat supplied in generator}) \\ &= (h_2 - h_1) / (h_3 - h_2) \end{aligned}$$

- Advantage of using absorption system is that work required for increasing the pressure of a liquid (pump) is very less compared to vapor (compressor).
- So a vapor absorption system requires small amount of high grade energy (pump work) whereas a vapor compression system requires large amount of high grade energy (compressor work).
- Compared to **heat (low grade energy)** supplied in the generator, pump **work (high grade energy)** is negligible. So majority source of energy input is heat.
- But COP of a vapor absorption system is less than vapor compression system of same capacity is less because of using large amount of low grade energy.

# Comparison between VC and VA systems

## VAPOR COMPRESSION SYSTEM

- Compressor work operated
- High COP because of using high grade energy(work)
- Performance is very sensitive to evaporator temperature
- COP reduces considerably at part loads
- Presence of liquid at the exit of the evaporator may damage compressor.
- Superheating at the evaporator exit increases compressor work
- Many moving parts
- Regular maintenance required
- Higher noise and vibrations
- Small systems are compact and large systems are bulky (e.g. house hold)
- Economical when electricity is available (house, malls etc)

## VAPOR ABSORPTION SYSTEM

- Heat operated
- Low COP because of using low grade energy(heat)
- Performance not very sensitive to evaporator temperature
- COP doesn't reduce considerably at part loads
- Presence of liquid at the exit of the evaporator is not a problem
- Superheating at the evaporator exit is not a problem
- Few moving parts
- low maintenance required
- Less noise and vibrations
- Small systems are bulky and large systems are compact (e.g. ice plants)
- Economical when waste heat is available in large quantity (industries)



**RSET**  
RAJAGIRI SCHOOL  
ENGINEERING & TECHNOLOGY

# CAPACITY OF A REFRIGERATION SYSTEM

- **TON OF REFRIGERATION (TR)** – latent heat of fusion absorbed by melting 1 ton of ice in 24 hours.

- **$1 TR = 3.5 kW$**

- **Maximum possible(ideal) COP a refrigerator can attain**

**= Carnot COP**

**=  $Q_1 / W$**

**=  $Q_1 / (Q_2 - Q_1)$**

**=  $T_1 / (T_2 - T_1)$**

**= Evaporator Temperature**

**Condenser Temperature - Evaporator temperature**

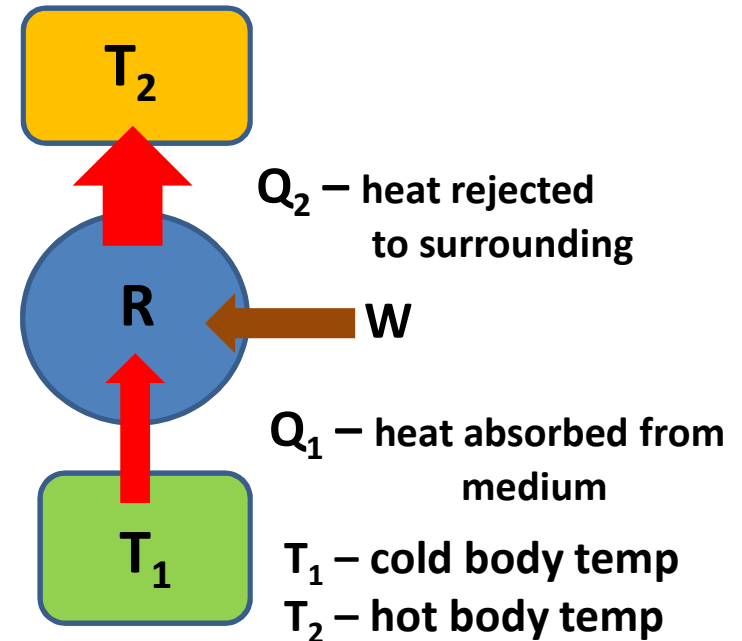



**RSET**

RAJAGIRI SCHOOL OF  
ENGINEERING & TECHNOLOGY

# **FIND RATED COP AND TONNAGE OF THE VAPOR GIVEN VAPOR COMPRESSION SYSTEM**

<b>SAMSUNG</b>		
<b>AIR CONDITIONER</b>		
MODEL	AW05M0YBC	
CAPACITY (COOLING)	5,400KJ/h	
VOLTAGE/FREQUENCY	230V~,60Hz	
CURRENT	2.5A	
POWER INPUT	540W	
REFRIGERANT	(R22) 290g	
USE 15 AMP. TIME DELAY FUSE or CIRCUIT BREAKER.		
DESIGN PRESSURE	HIGH	21.0kg/cm <sup>2</sup>
	LOW	10.5kg/cm <sup>2</sup>
SERIAL NO.:	PAFL600615	
COMP. THERMALLY PROTECTED.		
SAMSUNG ELECTRONICS CO.,LTD		
MADE IN CHINA		

***Rated refrigeration effect (capacity)***  
***= 5400 kJ/h***  
***=1.5 kW***  
***= 0.43 TR***

***Rated Power input = 0.54 kW***

***Rated COP =  $\frac{\text{Rated Ref effect}}{\text{Rated power input}} = 3$***

***Refrigerant used – R22 (250 g)***

***Condenser pressure = 21 kg/cm<sup>2</sup>***

***Evaporator pressure = 10.5 kg/cm<sup>2</sup>***



**RSET**

RAJAGIRI SCHOOL OF  
ENGINEERING & TECHNOLOGY

# ***STUDY OF HOUSEHOLD REFRIGERATOR***

- *Home Refrigerator, often called a “fridge”, has become an essential household appliance.*
- *Refrigerators are extensively used to store fruits, vegetables and other edible products which perish if not kept well below the room temperatures, normally a few degrees above 0°C, the freezing point of water.*
- *A refrigerator is a cooling appliance that transfers heat from its thermally insulated compartment to the external environment, and thus cooling the stored food in the compartment.*
- *It also normally houses a “freezer”, where temperatures below the freezing point of water are maintained, primarily to make ice and store frozen food.*
- *It also have Crisper which draws inside moisture to keep vegetables and fruits fresh for longer time, is normally inbuilt in most of home refrigerators.*





**RSET**

RAJAGIRI SCHOOL OF  
ENGINEERING & TECHNOLOGY

# **REFRIGERATOR COMPARTMENTS**



# **TYPES OF HOUSEHOLD REFRIGERATORS**

*Two types of home refrigerators are typically available in market.*

## **1. DIRECT COOL REFRIGERATORS:**

- *These refrigerators are with or without crisper, ice making or frozen food storage compartment.*
- *Cooling of food is primarily obtained by **natural convection** within the refrigerator. However, some refrigerators may have a fan to avoid internal condensation of water but are not claimed as 'frost free'.*
- *Formation of frost/ice in the refrigerator reduces cooling. Therefore these refrigerators need manual defrosting periodically.*

# **ICE BUILT UP IN DIRECT COOLING REFRIGERATION SYSTEM**



*The ice built up on the surface of the evaporator coil provides an additional resistance to heat transfer.*

*This decreases the heat absorption rate. So this ice should be removed manually periodically .*

# TYPES OF HOUSEHOLD REFRIGERATORS

## **2. FROST FREE REFRIGERATORS:**

- *These refrigerators cool the stored food **through continuous internal movement of air** that restricts the formation of frost and sticking of food items with each other.*
- *A frost free freezer has three basic parts a **timer**, a **heating coil** and a **temperature sensor**. The heating coil is wrapped around the freezer coils. Every six hour or so, the timer turns on the heating coil and **this melts the ice off the coil**.*
- *When all the ice is removed, the temperature sensor senses the temperature rising above  $0^{\circ}\text{C}$  and turns off the heating coil.*



**RSET**

RAJAGIRI SCHOOL OF  
ENGINEERING & TECHNOLOGY

# DEFROST MECHANISM

Hot refrigerant  
To condenser

**OFF**

**12:00pm**

**TIMER**

Hot refrigerant  
bypass valve

**ON**

**START**  
**-18 °C**

**TEMPERATURE  
SENSOR**

Heating Coil wrapped  
over Evaporator tube

cold refrigerant  
to expansion valve

Hot refrigerant  
From compressor

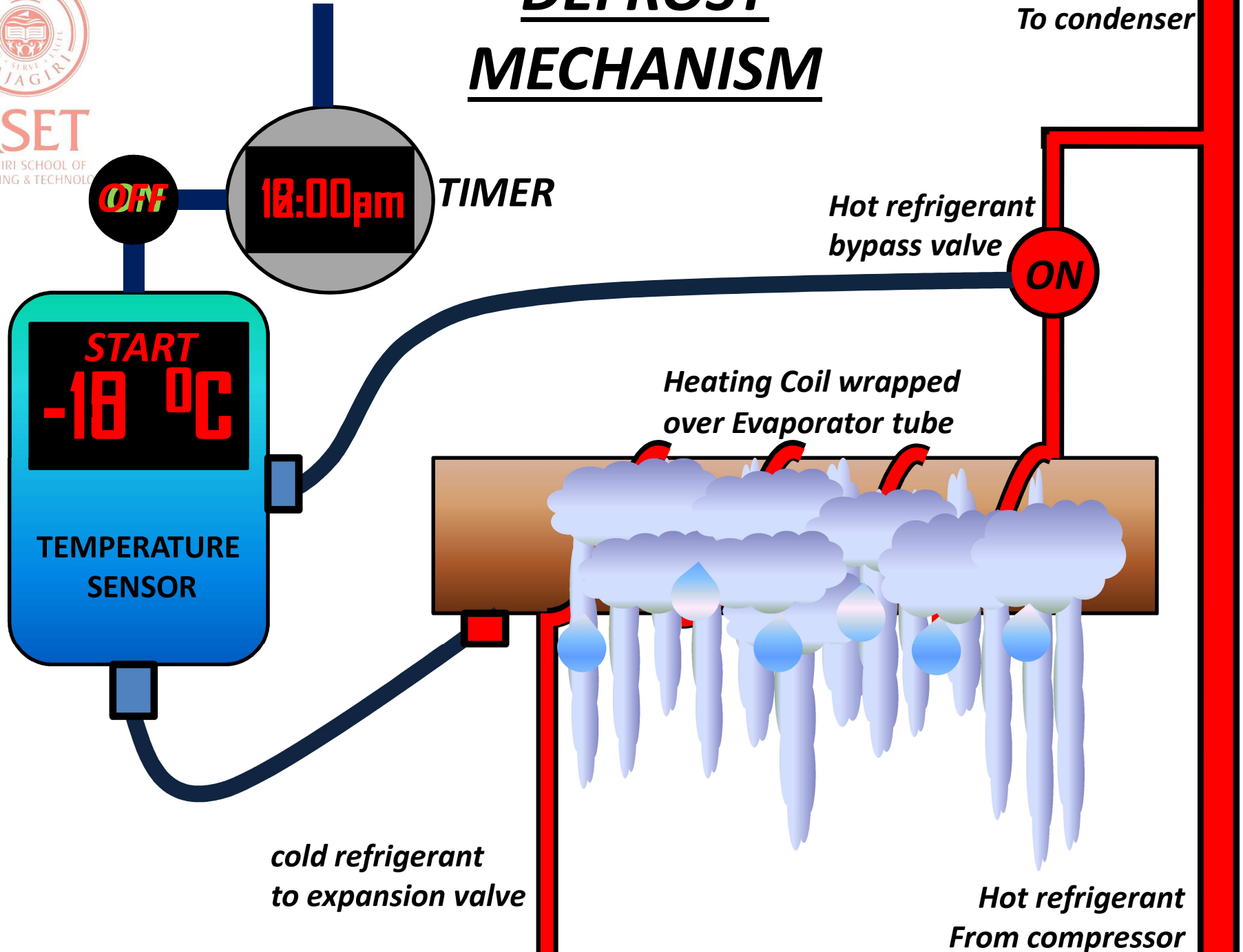



RSET

RAJAGIRI ENGINEERING COLLEGE

# **BEFORE BUYING A REFRIGERATOR**

## **1. CHOOSE THE RIGHT SIZE**

- *Make sure you are choosing a refrigerator that is approximately sized for your storing and cooling needs.*
- *If your fridge is too small, you may be overworking it. If it is too large, you are paying higher initial cost, and potentially wasting energy and home space.*
- *Always ascertain the storage volume of the refrigerator because this is the actual space available to you for storing food items. Therefore make a judicious decision while buying the refrigerator.*



# BEFORE BUYING A REFRIGERATOR

RSET

RAJAGIRI SCHOOL OF  
ENGINEERING & TECHNOLOGY

## 2. IDENTIFY THE RIGHT LOCATION

- *While placing the refrigerator in home, ensure that it is at least 100 mm (4 inches away) from the walls to facilitate effective heat rejection particularly from the rear side.*
- *Care should be taken that the unit is sufficiently away from heat sources such as stove, oven and direct solar radiation. These heat sources affect the heat dissipation from the fridge condenser, and may force the compressor to run longer leading to more electricity consumption.*
- *The refrigerator unit should also be leveled appropriately to ensure that its door closes easily and tightly after its use to minimize unwanted warm air infiltration in the cooling space.*



# ***ENERGY SAVING TIPS***

**RSET**  
RAJAGIRI SCHOOL OF  
ENGINEERING & TECHNOLOGY

- *Make sure that refrigerator is kept away from all sources of heat, including direct sunlight, and appliances such as cooking range, oven, radiators, etc.*
- *Refrigerator motors and compressor generate heat, so allow enough space for continuous airflow around refrigerator. If the heat does not escape, the refrigerator's cooling system will work harder and use more energy.*
- *Over filling of the storage capacity of refrigerator with food items should be avoided, to ensure adequate air circulation inside.*
- *Do not keep fridge door open for longer period as it consumes more electricity. Therefore decide what you need before opening the door. By this practice, you will reduce the amount of time the door remains open.*
- *Allow hot and warm foods to sufficiently cool down before putting them in refrigerator. It is also advisable to put them in sealed (air tight) containers. Refrigerator will use less energy and water condensation will also be lesser.*





# **ENERGY SAVING TIPS**

- *Make sure that refrigerator's rubber door seals are clean and tight. They should hold a slip of paper snugly. If paper slips out easily, replace the door seals. The other way to check this is to place a flashlight inside the refrigerator when it is dark, and close the door. If light around the door is seen, the seals need to be replaced.*
- *When dust builds up on refrigerator's condenser coils, the compressor works harder and uses more electricity. Therefore clean the coils regularly.*
- *In manual defrost refrigerator, accumulation of ice reduces the cooling power by acting as unwanted insulation. Therefore, defrost freezer compartment regularly in a manual defrost refrigerator.*
- *Give the maintenance contract of refrigerator directly to the manufacturer or its authorized company which has trained and well-qualified technical staff.*
- *If refrigerator is older and needs major repairs, it is likely to become inefficient after repairs. It may be advisable to replace old refrigerator with a new and energy-efficient one.*



**RSET**  
RAJAGIRI SCHOOL OF  
ENGINEERING & TECHNOLOGY

# ***AIR CONDITIONING***



RSET

RAJAGIRI SCHOOL  
ENGINEERING & TECHNOLOGY

# PSYCHROMETRY

• **PSYCHROMETRY** is the study of the properties of mixtures of air and water vapor.

- Atmospheric air makes up the environment in almost every type of air conditioning system.
- Hence a thorough understanding of the properties of atmospheric air and the ability to analyze various processes involving air is fundamental to air conditioning design.



# PSYCHROMETRIC TERMS

**RSET**  
RAJAGIRI SCHOOL OF  
ENGINEERING & TECHNOLOGY

**DRY AIR-** When the moisture content is 0 , then the air is known as dry air

**SATURATED AIR-** At a given temperature and pressure the dry air can only hold a certain maximum amount of moisture. When the moisture content is maximum, then the air is known as saturated air, which is established by a neutral equilibrium between the moist air and the liquid or solid phases of water.

**DRY BULB TEMPERATURE (DBT)-** It is the temperature of the moist air as measured by a standard thermometer or other temperature measuring instruments.

**WET BULB TEMPERATURE(WBT)-** Temperature of the moist air as measured by standard thermometer when its bulb is wound by a wet wick.

for dry air  $WBT < < DBT$

for saturated air  $WBT = DBT$

**DEW POINT TEMPERATURE(DPT)-** if moist air is cooled at constant pressure the temperature at which moisture in the air begins to condense.



**RSET**

RAJAGIRI SCHOOL OF  
ENGINEERING & TECHNOLOGY

# DRY BULB AND WET BULB TEMPERATURES

- For dry air WBD will be maximum

- For saturated air WBD will be 0

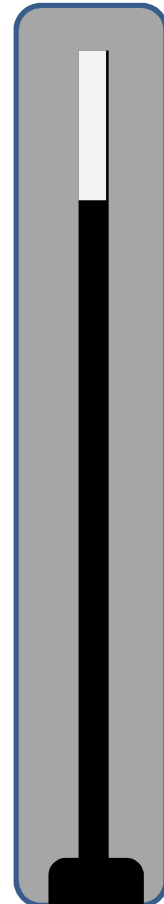

Dry bulb thermometer



Wet bulb depression

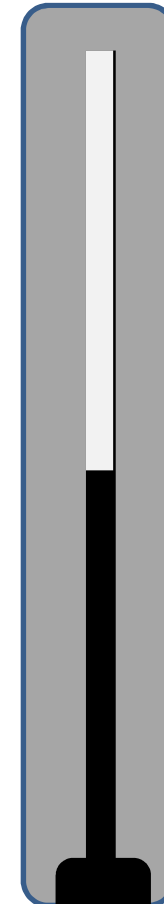

Wet bulb thermometer

Heat used for vaporization of water to atmospheric air

Heat from atmospheric air

Heat from atmospheric air

**Note: If atmospheric air is saturated then vaporization won't take place so whole of the heat will be transmitted to the wet bulb. So in case of saturated air DBT = WBT**



**RSET**  
ENGINEERING & TECHNOLOGY

# PSYCHROMETRIC TERMS

**HUMIDITY RATIO (w)** - The humidity ratio (or specific humidity) is the mass of water associated with each kilogram of dry air. i.e.  $w = m_v / m_a$  kg/kg dry air

**RELATIVE HUMIDITY (Φ)** - It is defined as the ratio of (amount of water vapor in moist air, w) to (amount of water vapor in saturated air,  $w_{sat}$ ) at the same temperature and pressure. i.e.  $\Phi = w/w_{sat} \times 100 \%$

For saturated air RH= 100 %

For dry air RH = 0 %

**ENTHALPY (h)**- The enthalpy of moist air is the sum of the **enthalpy of the dry air** and the **enthalpy of the water vapor**. i.e.  $h = h_a + h_v$  kJ/kg dry air

Enthalpy values are always based on some reference value.

At 0°C,  $h_a = 0$  and  $h_v = 0$

**SPECIFIC VOLUME (v)**- It is defined as the number of cubic meters of moist air(V) per kilogram of dry air( $m_a$ ). i.e.  $v = V / m_a$  m<sup>3</sup>/kg dry air



# PSYCHROMETRIC PROCESSES

RSET

1. SENSIBLE HEATING – During this process moisture content of the air remains constant. But its temperature increases as it flows over a heating coil.
2. SENSIBLE COOLING – During this process moisture content of the air remains constant. But its temperature decreases as it flows over a cooling coil. For the moisture to remain constant the surface of the cooling coil should be dry and  $DBT_{in} > T_{surface} > DPT_{in}$  to avoid condensation of moisture.

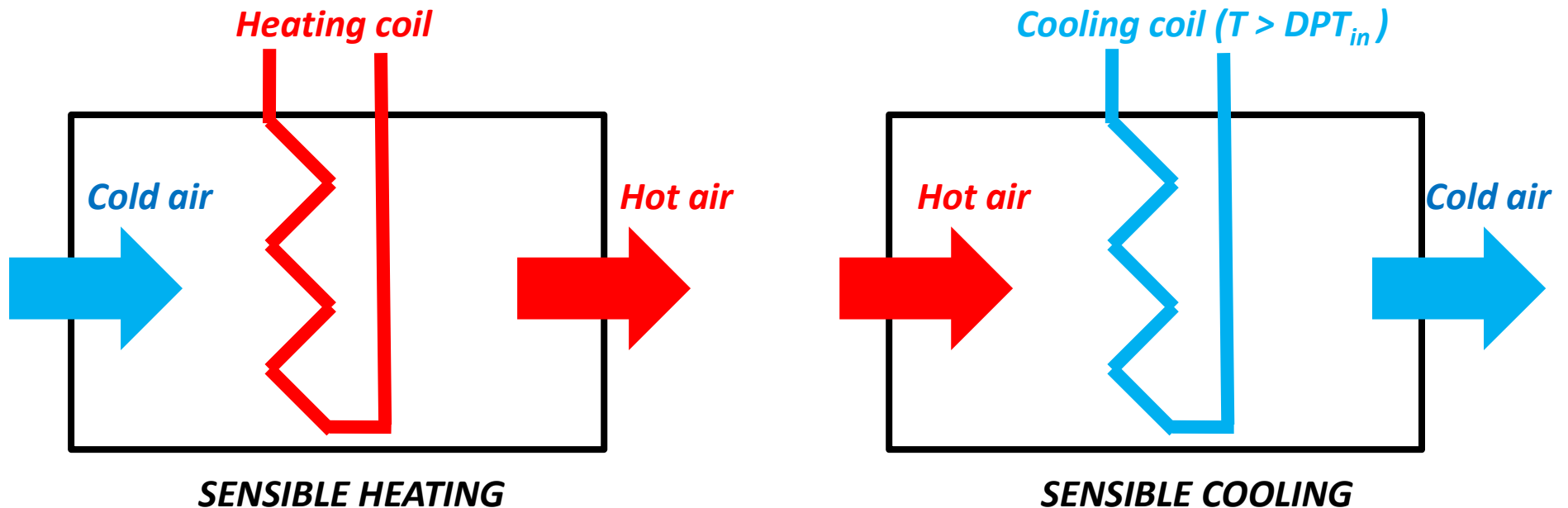



**RSET**

RAJAGIRI SCHOOL OF  
ENGINEERING AND TECHNOLOGY

# PSYCHROMETRIC PROCESSES

3. HEATING AND HUMIDIFICATION- in this process air is first sensibly heated by a heating coil followed by spraying steam via steam nozzle.
4. HEATING AND DEHUMIDIFICATION - This process is achieved by using hygroscopic materials. Absorption of moisture by hygroscopic material(liquid/solid) is an exothermic reaction, as a result heat is released and temperature of air increases.

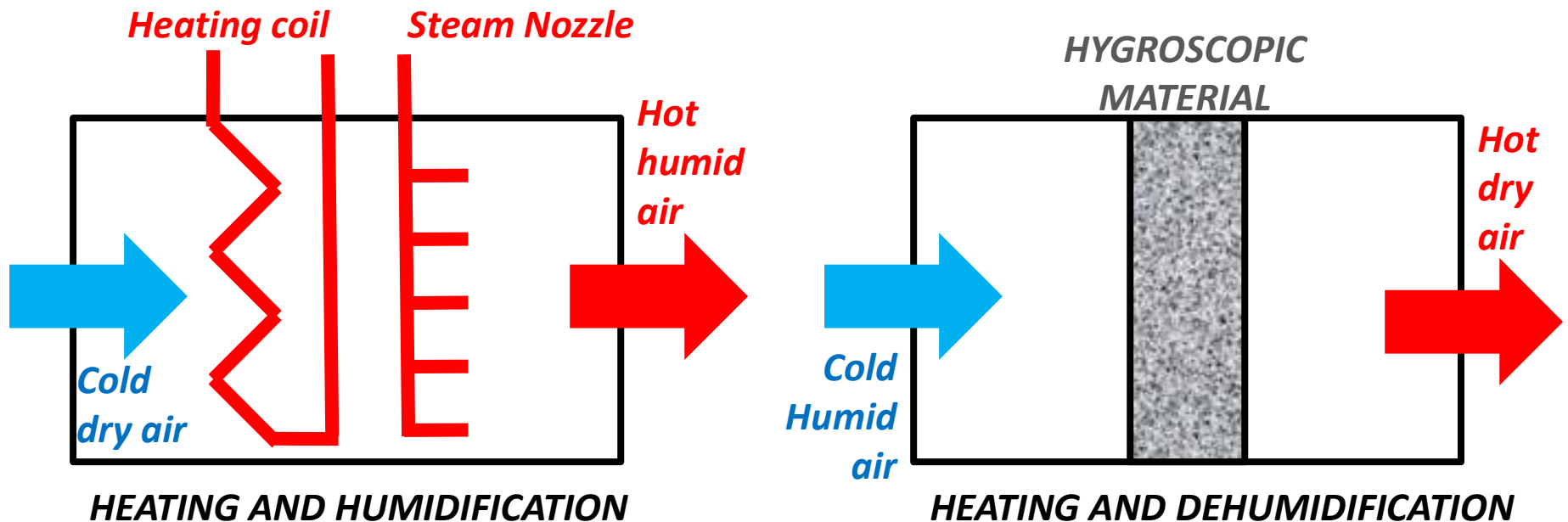





# PSYCHROMETRIC PROCESSES

RSET

5. COOLING AND HUMIDIFICATION- In this process air is cooled by spraying cold water into air stream. Also  $DBT_{in} > T_{water} > DPT_{in}$

6. COOLING AND DEHUMIDIFICATION - In this process air is cooled and moisture is removed when it flows over a cooling coil whose surface temperature should be less than the DPT at the outlet state. i.e.  $T < DPT_{out}$

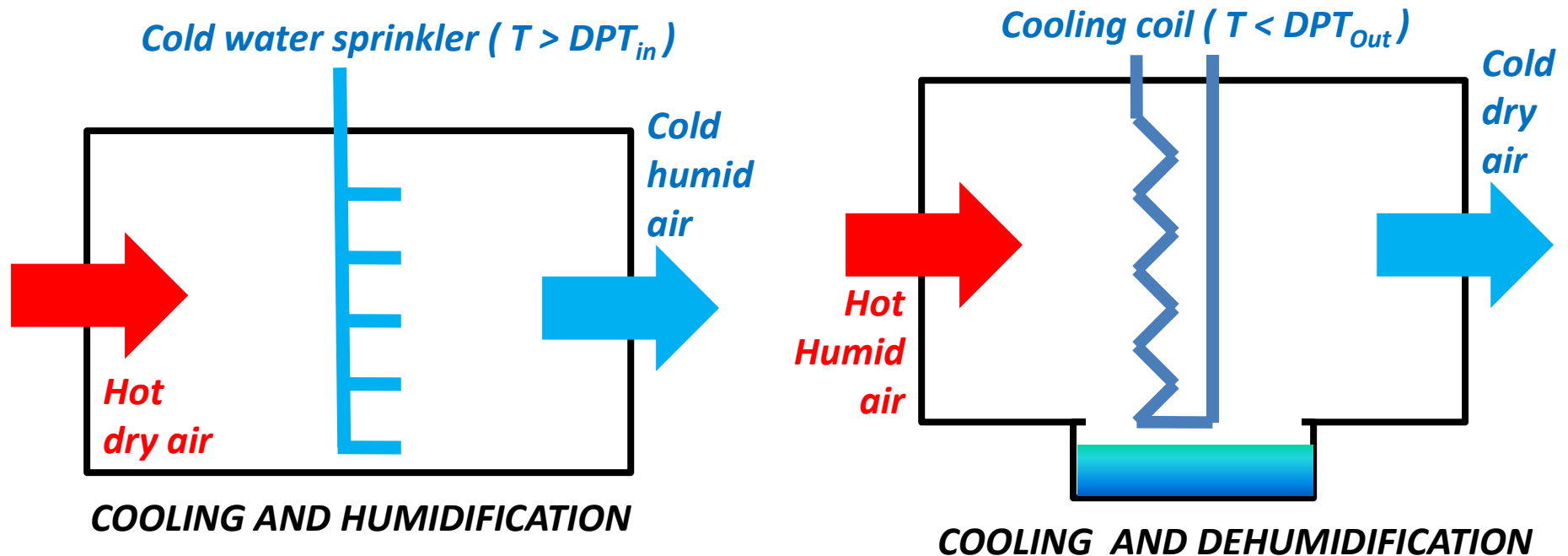



# PSYCHROMETRIC CHART

Simplified psychrometric chart at 1 atm total pressure

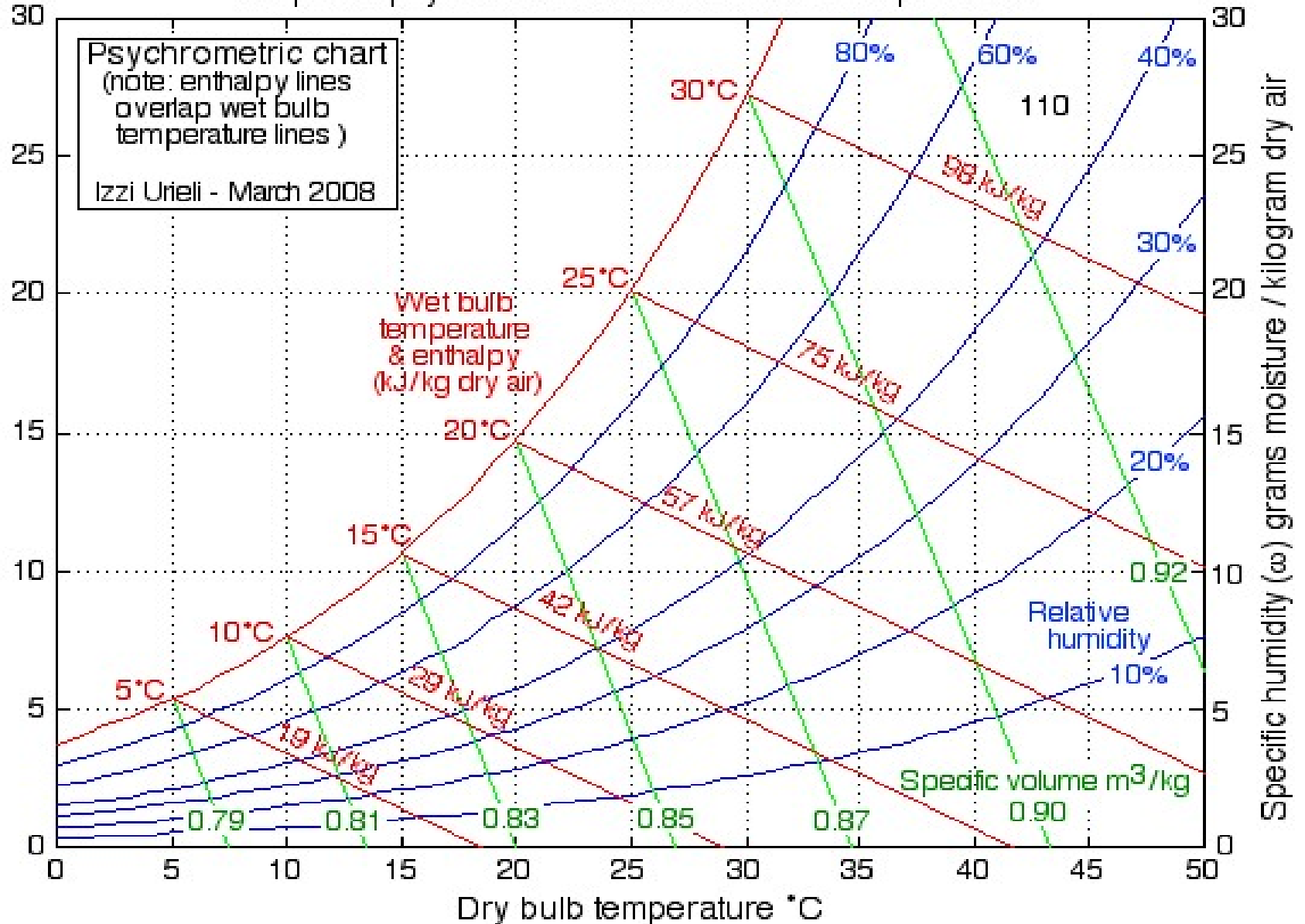



**RSET**

RAJAGIRI SCHOOL OF  
ENGINEERING AND TECHNOLOGY

# PSYCHROMERTIC PROPERTY CURVES

- If we know any two Psychrometric properties we can locate the state point of moist air in psychrometric chart.
- And can easily identify how much energy ( $\Delta h$ ) has to be supplied or removed to bring the air to a required state.
- From these data we can design an AC system

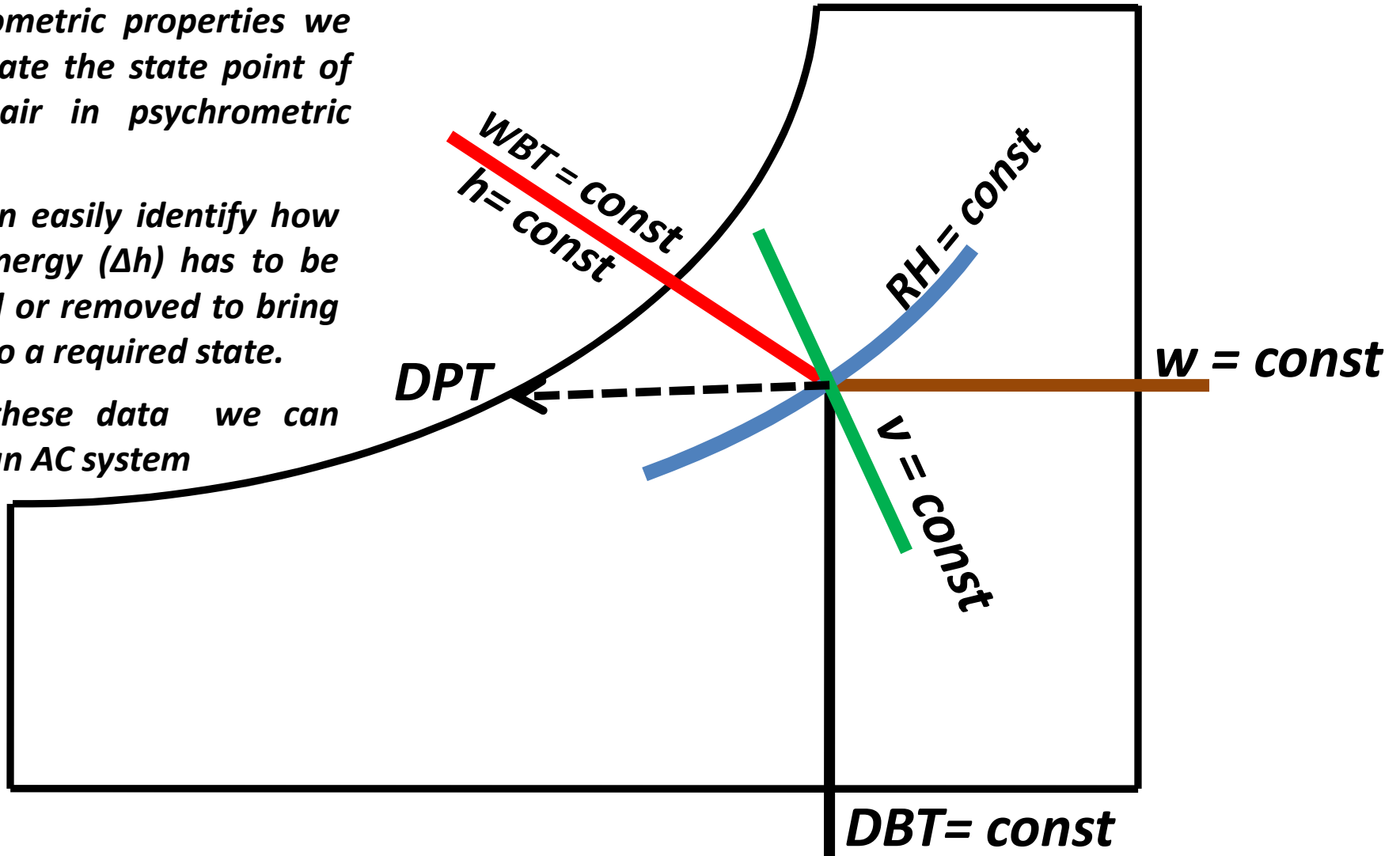



# HEAT LOAD FROM PSYCHROMETRIC CHART

Simplified psychrometric chart at 1 atm total pressure

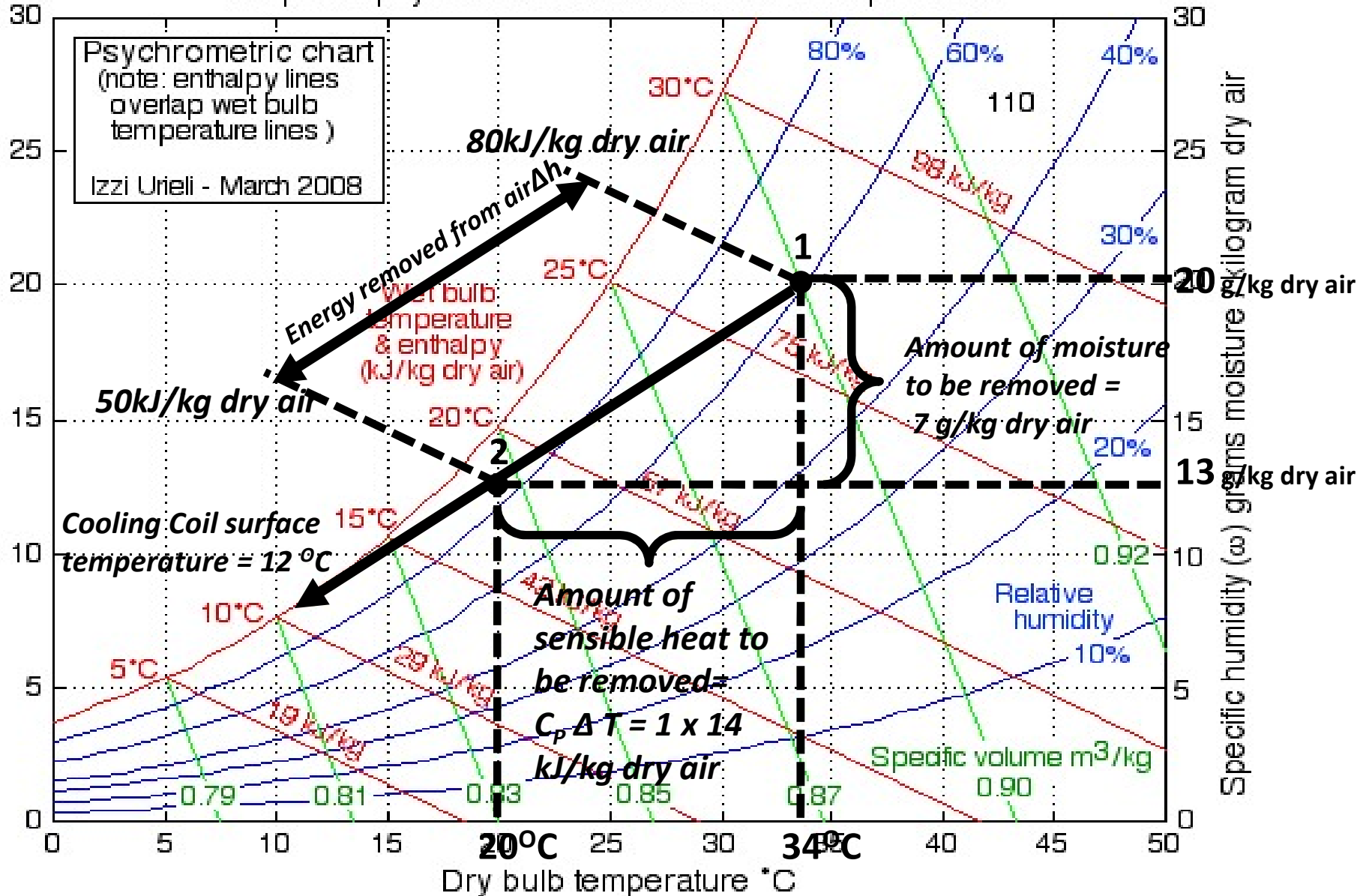



**RSET**

RAJAGIRI SCHOOL OF  
ENGINEERING & TECHNOLOGY

# PSYCHROMERTIC PROCESSES

- O-A**     **SENSIBLE HEATING**
- O-B**     **SENSIBLE COOLING**
- O-C**     **HEATING + HUMIDIFICATION**
- O-D**     **HEATING + DEHUMIDIFICATION**
- O-E**     **COOLING + HUMIDIFICATION**
- O-F**     **COOLING + DEHUMIDIFICATION**

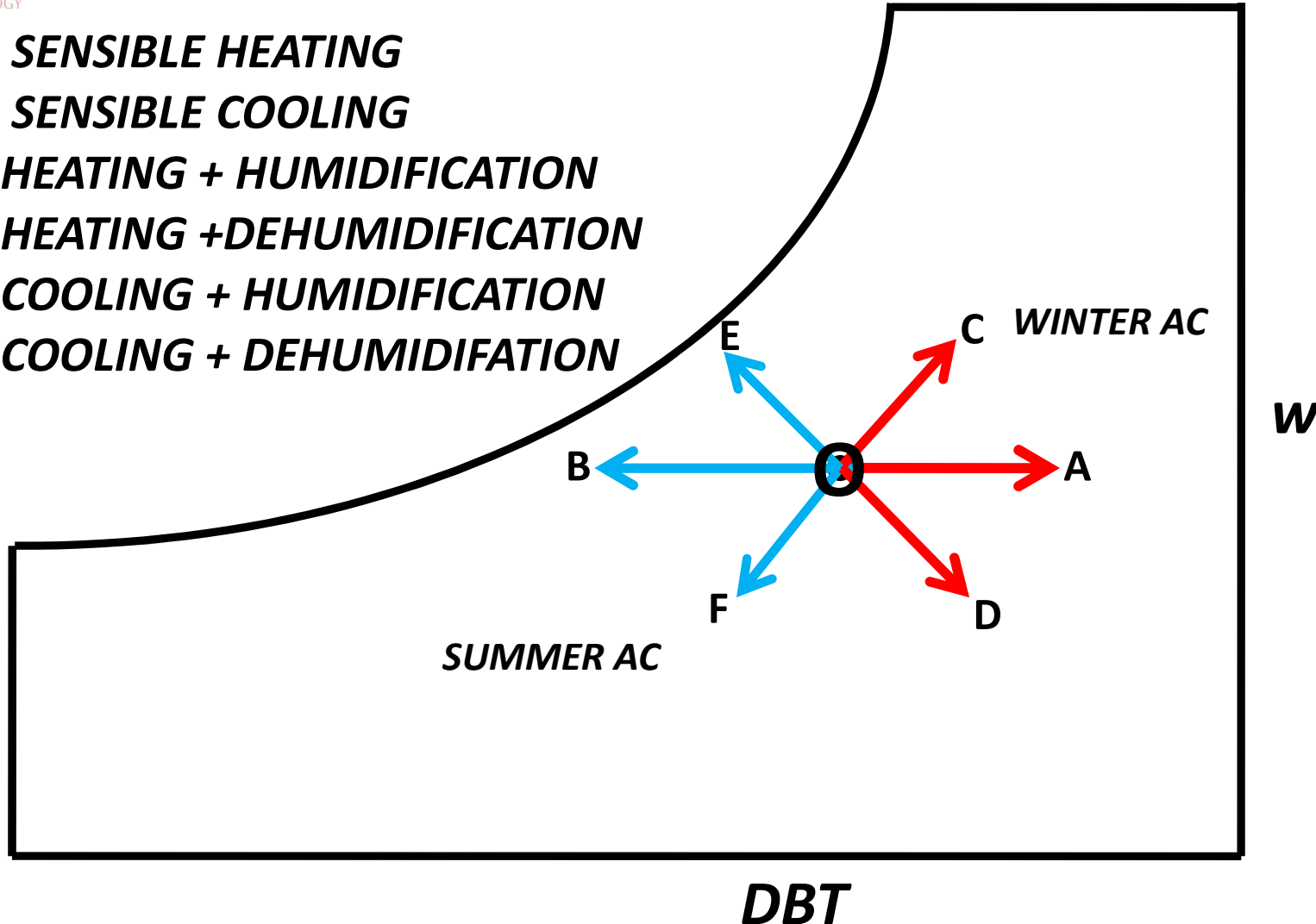



**RSET**  
RAJAGIRI SCHOOL OF  
ENGINEERING & TECHNOLOGY

# ***SUMMER AC***





**RSET**

RAJAGIRI SC  
ENGINEERING &

# ***SUMMER HEAT LOAD IN A ROOM***

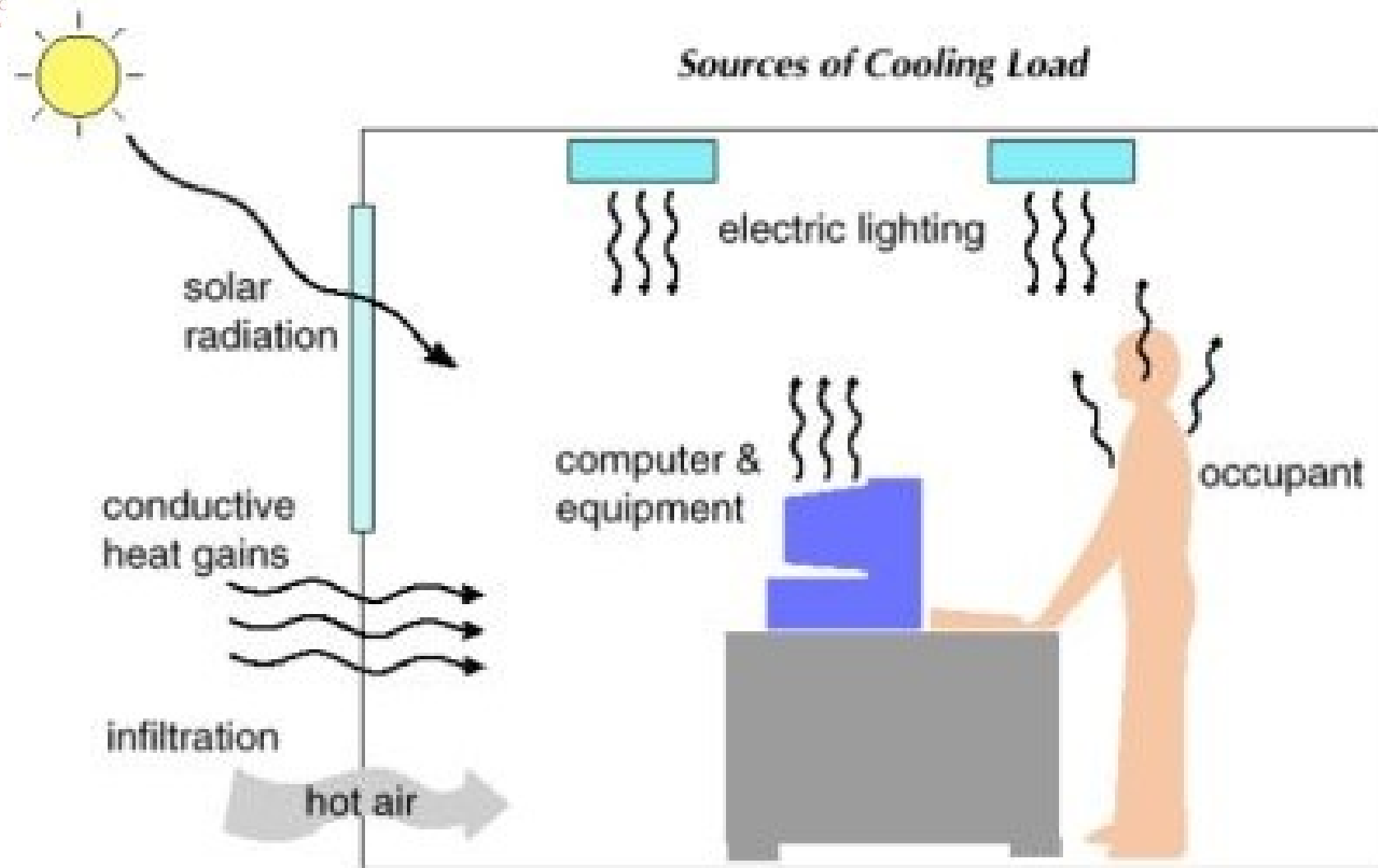



**RSET**

RAJAGIRI SCHOOL OF  
ENGINEERING AND TECHNOLOGY

# ***HUMAN THERMAL COMFORT***

• *As recommended by ASRAE, direct Factors which affect human thermal comfort are.*

- 1. Activity energy release      **70 W/m<sup>2</sup> or 1.2 met***
- 2. Clothing resistance            **0.007 m<sup>2</sup> K/W or 0.6 clo***
- 3. Air DBT                            **24 °C***
- 4. RH                                    **50 %***
- 5. Air velocity                        **0.15 m/s***

*Heat should be continuously carried away from the conditioned space to maintain this comfort level.*

*There are many source of heat including heat produced by human metabolism, solar radiation, heat conduction, moisture infiltration( from outside air and human perspiration), electrical appliances, cooking appliances etc*



# WINDOW AC

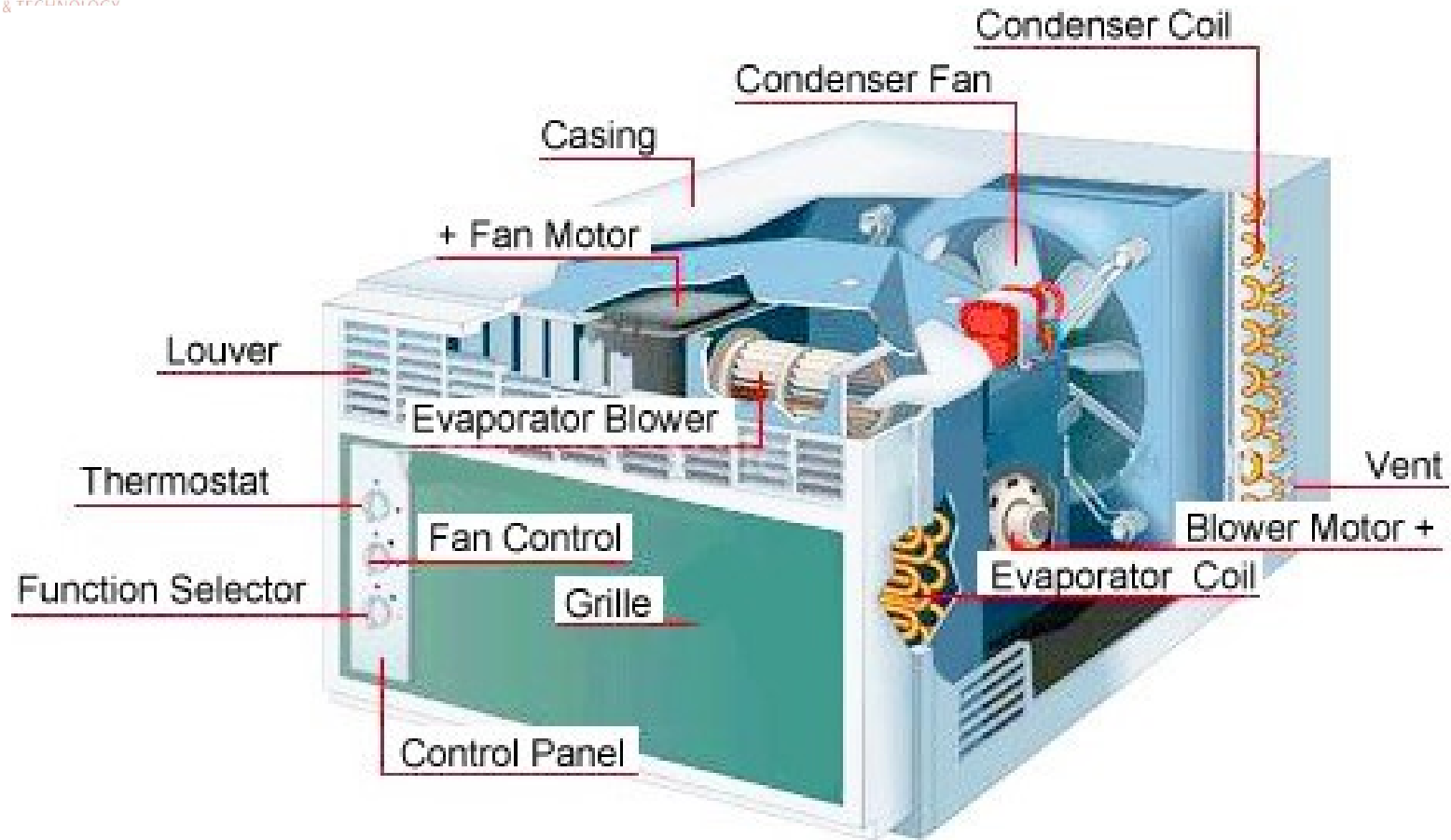



**RSET**  
RAJAGIRI SCHOOL OF  
ENGINEERING & TECHNOLOGY

# WINDOW AC SCHEMATIC

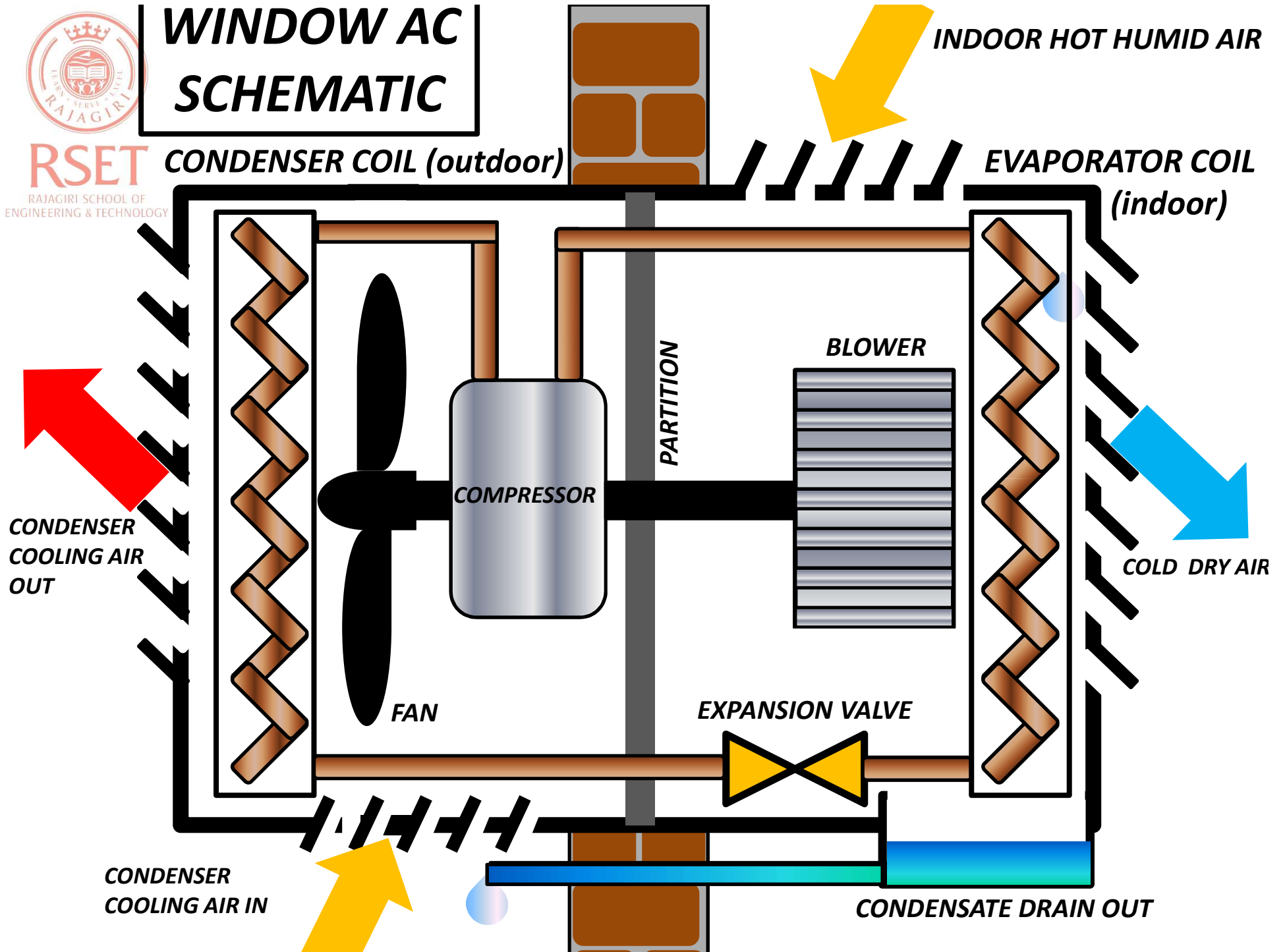



**RSET**

RAJAGIRI SCHOOL OF  
ENGINEERING & TECHNOLOGY

# WINDOW AC

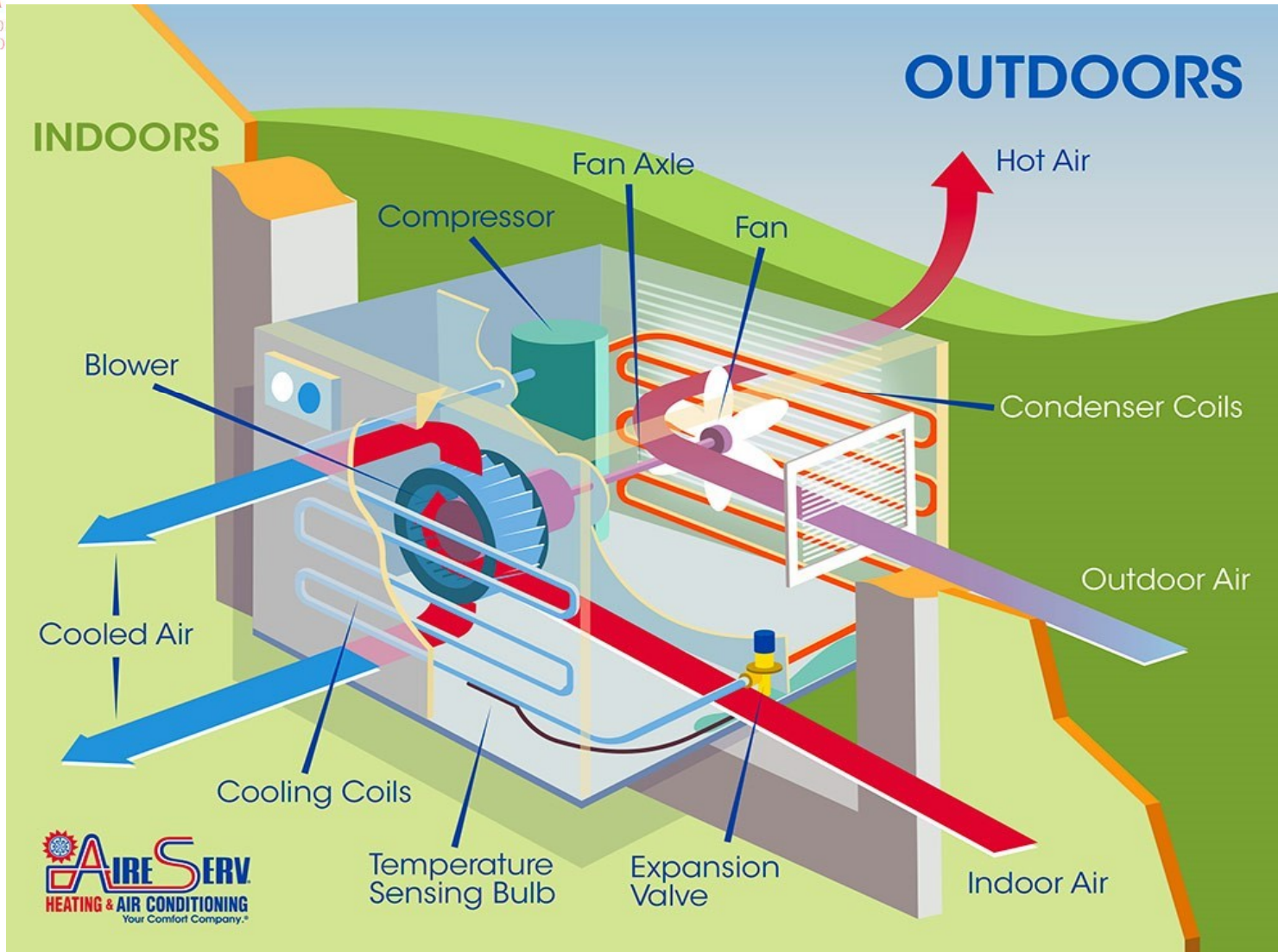



**RSET**  
RAJAGIRI SCHOOL OF  
ENGINEERING & TECHNOLOGY

# ***SPLIT AC***

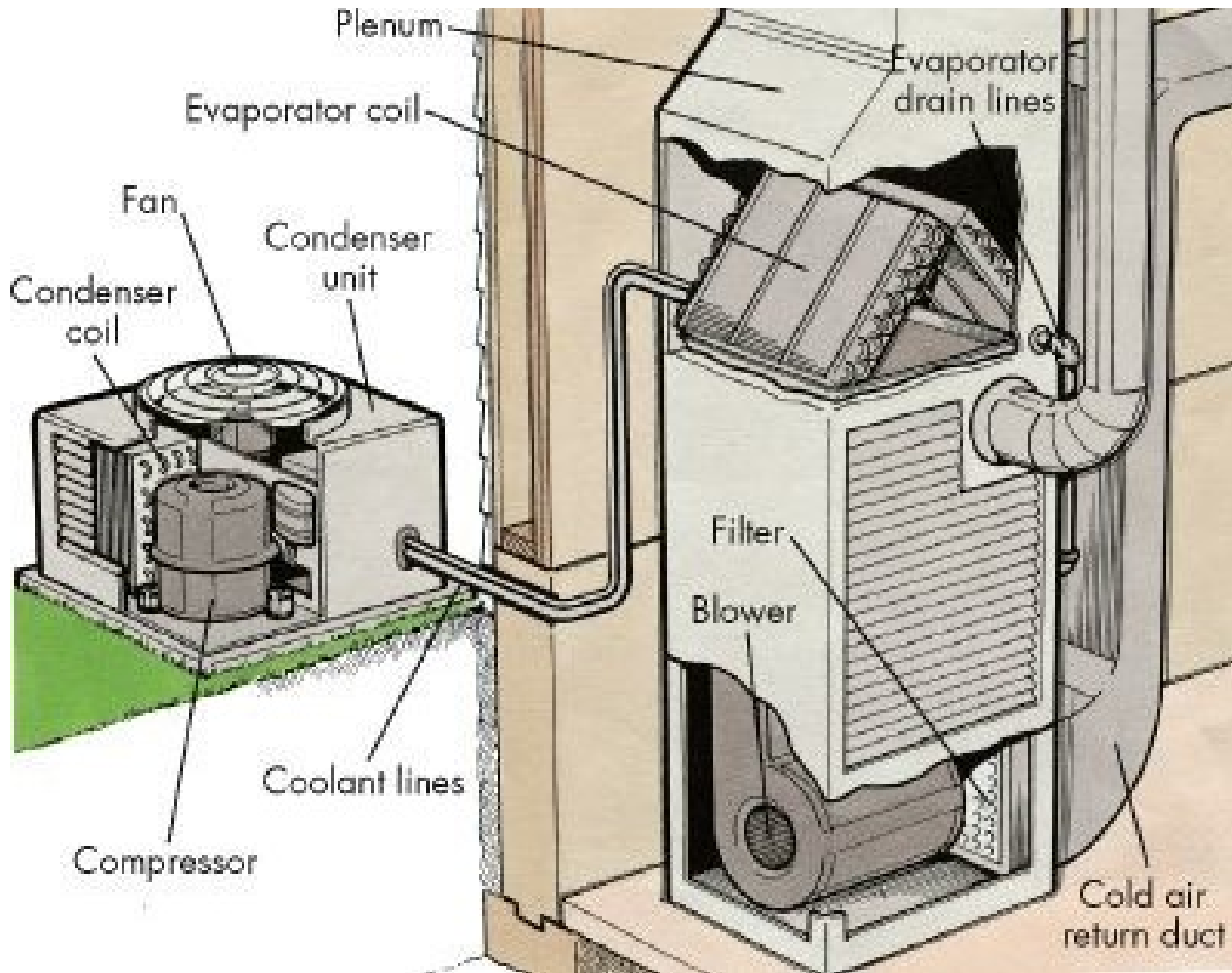

# ***SPLIT AC for multiple rooms***

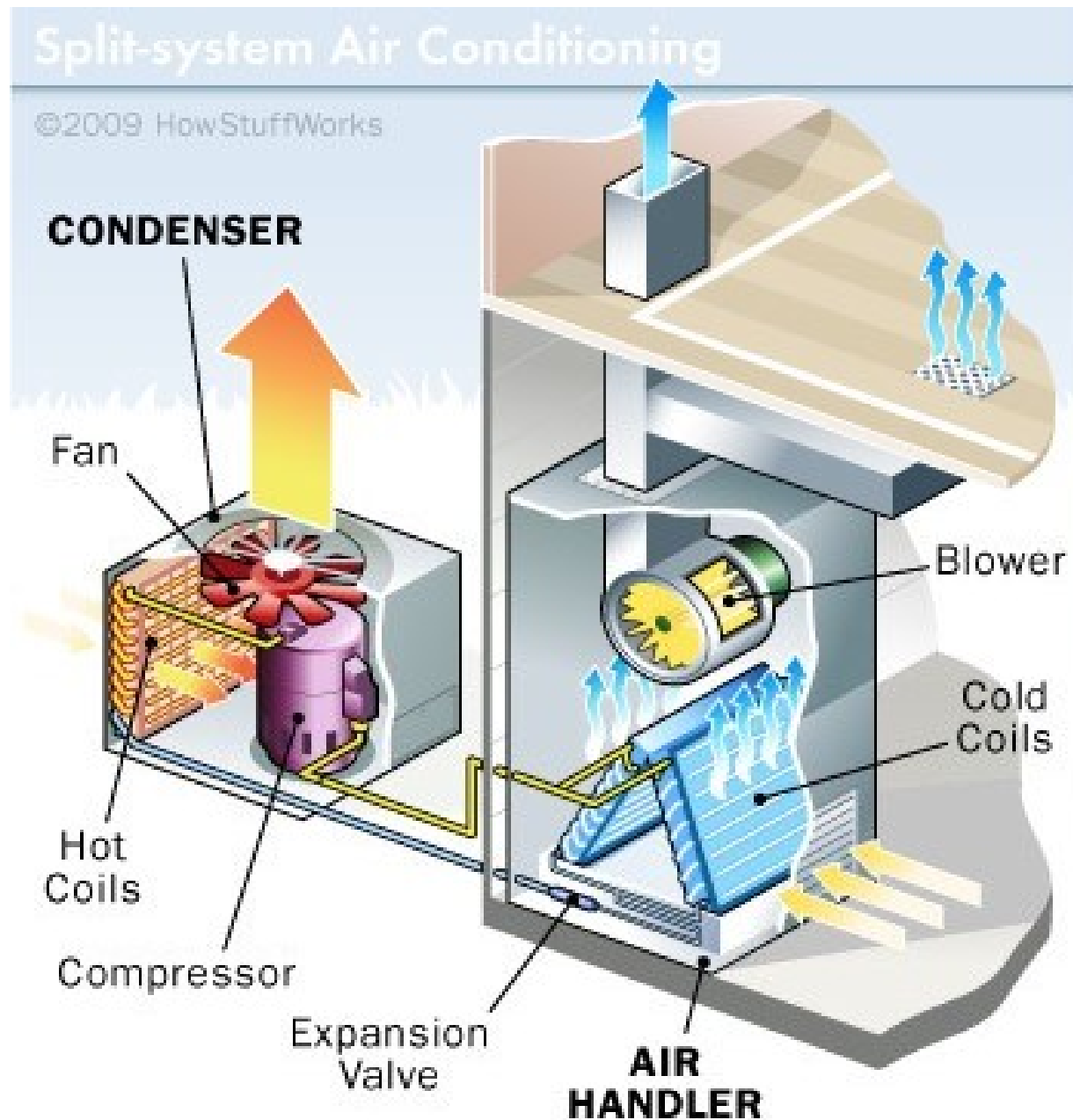



**RSET**  
RAJAGIRI SCHOOL OF  
ENGINEERING & TECHNOLOGY

# ***SPLIT AC duct system for multiple rooms***

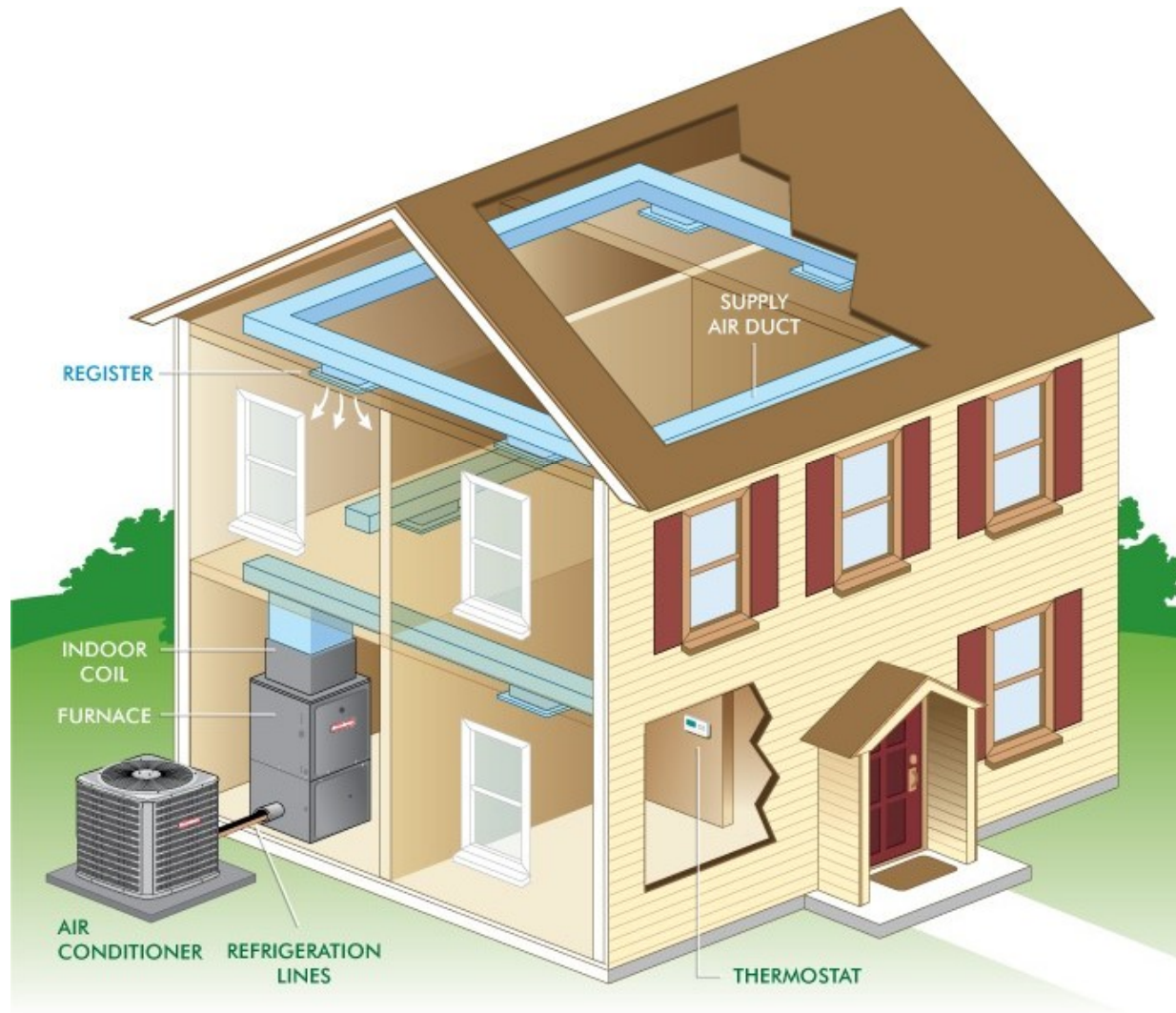

# ***SPLIT AC for single room***

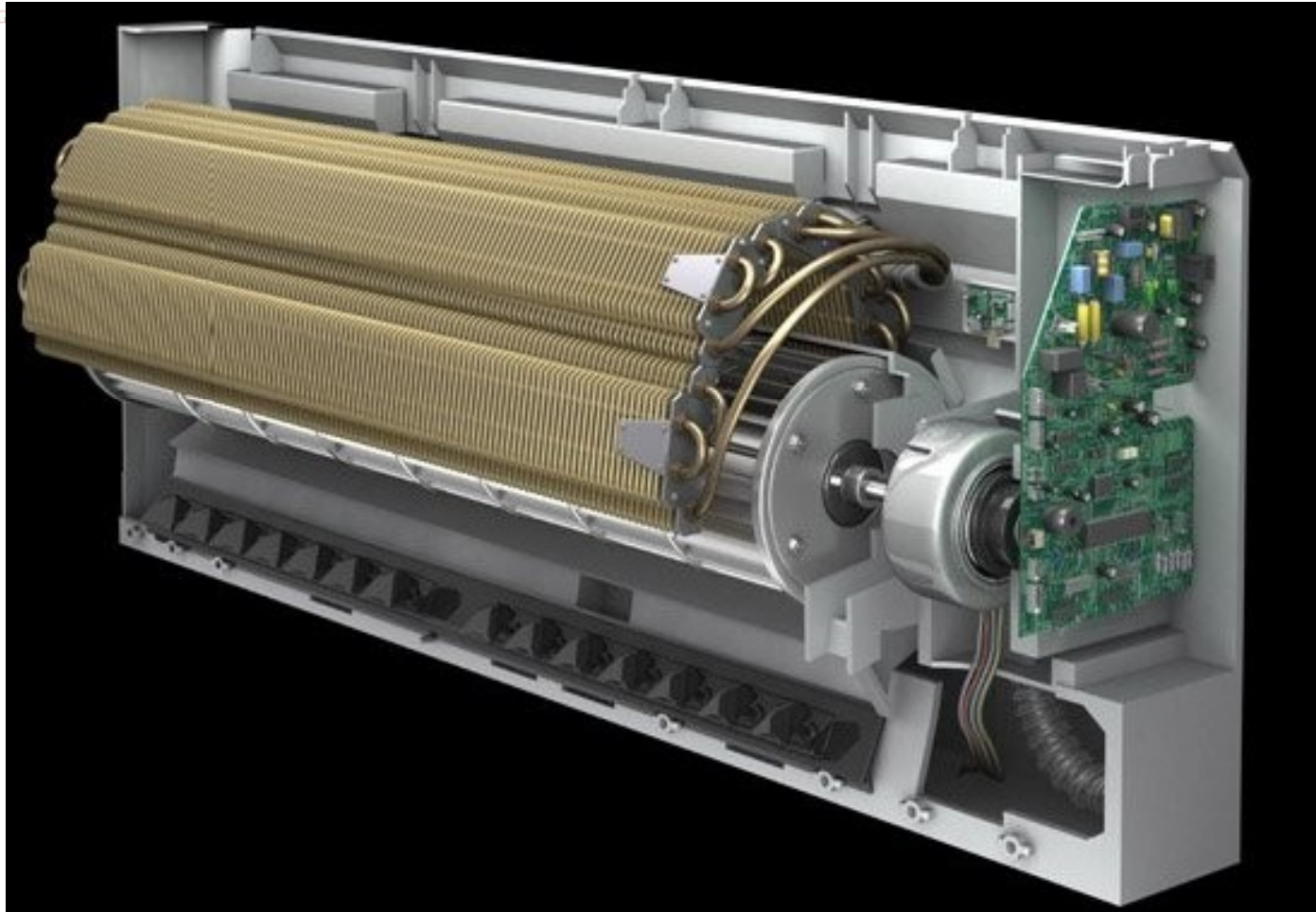



**RSET**  
RAJAGIRI SCHOOL OF  
ENGINEERING & TECHNOLOGY





**RSET**

RAJAGIRI SCHOOL OF  
ENGINEERING & TECHNOLOGY

# ***SELECTION CRITERIA FOR AC SYSTEMS***



# BEE Star Labels Explained



Look for stars on an appliance model. More stars means more electricity saving.

Look for the year on the label as star ratings change periodically when standards improve. A BEE 5 star rated model in 2013 may be equivalent to BEE 3/4 star model in 2014.

Appliance/Type	: XX/Split
Brand	: YYYY
Model/Year	: ABC/2007
Cooling Capacity (W)	: XX
Power Consumption (W)	: XX
Variable Speed Compressor	: Yes/No
Heat Pump	: Yes/No



Although BEE Star rated appliances do comply with Indian Standards, but higher star rating does not mean better quality.

BEE Star rating is available in following home appliances: Refrigerators, Air Conditioners, Water Heaters, T8 Tubelights, 1200 mm sweep Ceiling Fans.



# ***TYPES OF HEAT LOADS***

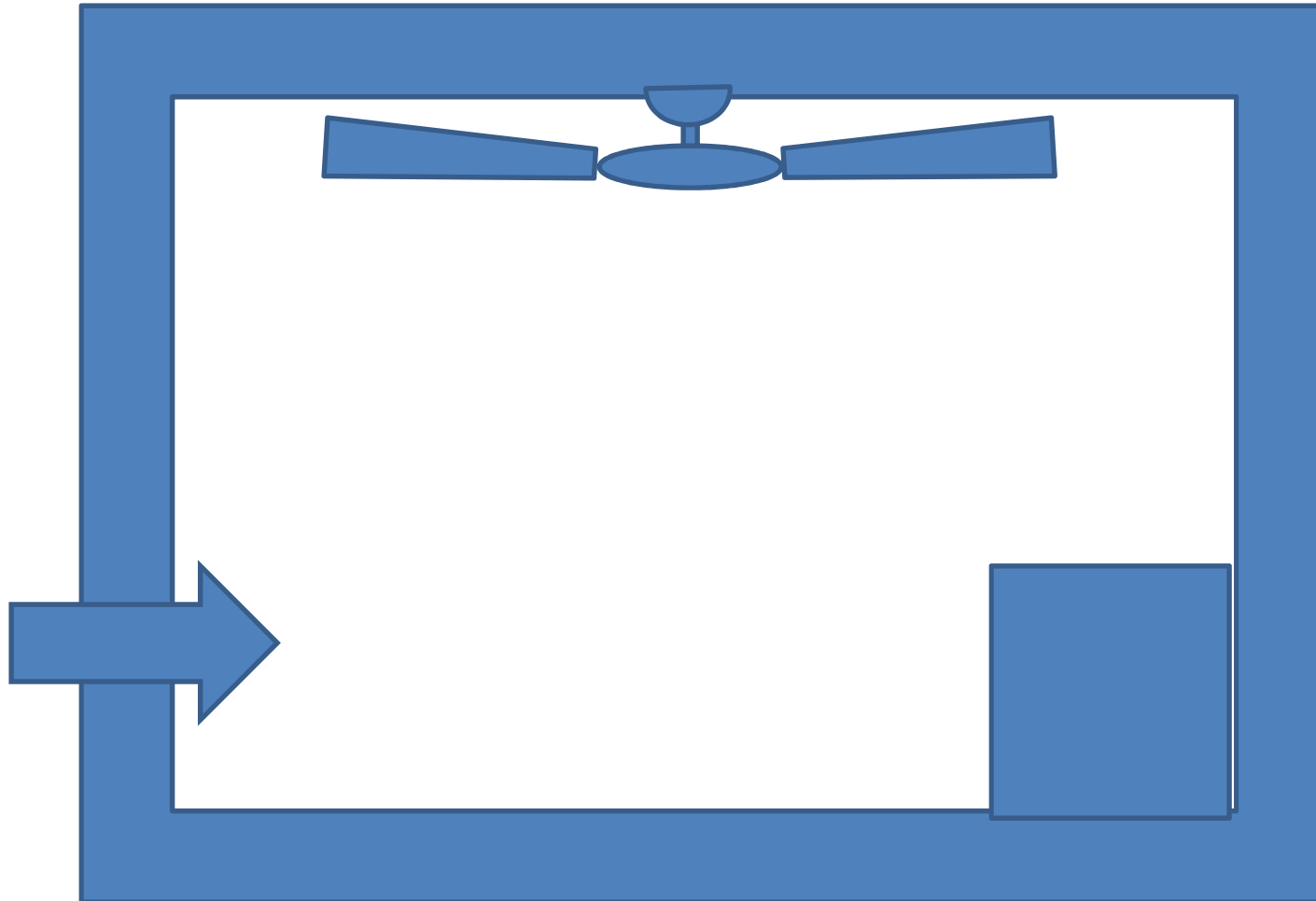



**RSET**

RAJAGIRI SCHOOL OF  
ENGINEERING & TECHNOLOGY

# **BEE STAR RATING AND LABELING OF REFRIGERATORS**

- *In May 2006, Bureau of Energy Efficiency (BEE), a statutory body under Ministry of Power (Government of India) launched **Standard and Labeling Program** of electrical home appliances.*
- *Under this program, for the benefit of general public, the appliance manufacturers could voluntarily affix BEE Star Label on their appliances showing the level of energy consumption by the appliance both in terms of **absolute values** as well as **equivalent number of stars** varying from one to five, in accordance with specific stipulation.*

# ENERGY EFFICIENCY RATING

## STAR RATING

(By BEE (Bureau of Energy Efficiency))

$$\text{EER (Energy Efficiency Ratio)} = \frac{\text{Cooling Capacity (In Watts)}}{\text{Input Wattage (In Watts)}}$$

Star Rating Slab#

Star Rating	EER (W/W)	
	Min.	Max.
1 Star ★	2.30	2.49
2 Star ★★	2.50	2.69
3 Star ★★★	2.70	2.89
4 Star ★★★★	2.90	3.09
5 Star ★★★★★	3.10	↑

#Still Applicable for 2012 & 2013 Window AC

From 2012 Star Rating Slab\*

Star Rating	EER (W/W)	
	Min.	Max.
1 Star ★	2.50	2.69
2 Star ★★	2.70	2.89
3 Star ★★★	2.90	3.09
4 Star ★★★★	3.10	3.29
5 Star ★★★★★	3.30	↑

\*Applicable for 2012 & 2013 Split AC

3 Star 1.5T Split AC (EER: 2.90) is more energy efficient than 3 Star 1.5T Window AC (EER: 2.70)

3 Star 1.5T Split AC (Input Wattage: 1800Watts) 3 Star 1.5T Window AC (Input Wattage 1950Watts)

Savings: 0.15 Units/hour>>>Savings Per Day@10hour operation: Rs.7.5/->>>Savings Per Month: Rs.225/-



**RSET**

RAJAGIRI SCHOOL OF  
ENGINEERING & TECHNOLOGY

# ENERGY EFFICIENCY RATING

## New BEE Energy Efficiency Ratings (EER) for Room Air Conditioners

STAR RATING LEVELS - Jan 1, 2014 - Dec 31, 2015

EER (W/W)

WINDOW AC

SPLIT AC

Star Rating	Minimum	Maximum	Star Rating	Minimum	Maximum
1 Star ★	2.50	2.69	1 Star ★	2.70	2.89
2 Star ★★	2.70	2.89	2 Star ★★	2.90	3.09
3 Star ★★★	2.90	3.09	3 Star ★★★	3.10	3.29
4 Star ★★★★	3.10	3.29	4 Star ★★★★	3.30	3.49
5 Star ★★★★★	3.30	-	5 Star ★★★★★	3.50	-